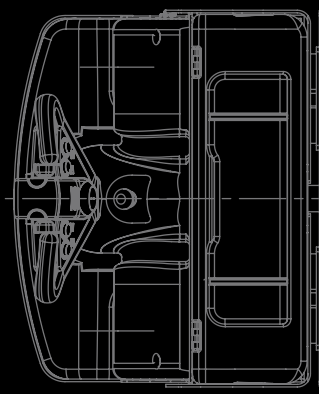


601, Western Industrial Estate, Dublin 12, Ireland  
t: +353 1 458 4836 e: sales@prolift.ie w: www.prolift.ie



The Lifting Equipment Specialists



www.prolift.ie



|   |     |
|---|-----|
| Introduction .....                              | 5   |
| Grade 100 Components .....                      | 7   |
| Grade 80 Components .....                       | 21  |
| Chain .....                                     | 41  |
| Lifting Points .....                            | 49  |
| Stainless Steel Chains and Components .....     | 59  |
| Shackles .....                                  | 75  |
| Wire Rope and Accessories .....                 | 87  |
| Polyester Lifting .....                         | 99  |
| Height Safety Solutions .....                   | 107 |
| Lashings and Transport .....                    | 115 |
| Manual Hoists and Winches .....                 | 123 |
| Trolley and Accessories .....                   | 141 |
| Electric Hoists and Winches .....               | 147 |
| Jib Cranes, Gantry Cranes and Accessories ..... | 175 |
| Vacuum Lifting Solutions .....                  | 197 |
| Pneumatic Hoists .....                          | 203 |
| Weighing and Measurement Devices .....          | 221 |
| Material Handling Range .....                   | 233 |
| Lift Tables .....                               | 267 |
| Construction Equipment .....                    | 273 |
| Plant Machinery Safety Devices .....            | 277 |





## Dear Customer,

Prolift Handling Ltd was formed in 2013 and is a wholly Irish owned company.

We are now the largest supplier of lifting, material Handling and Height Safety equipment in Ireland and are also recognised throughout Europe as a leading distributor within our industry.

Prolift are ISO 9001 approved and also LEEA accredited (Lifting Equipment Engineers Association)

The corner stone of our business is to supply high quality European manufactured products with full traceability that meets all EN standards and regulatory requirements.

We are delighted to present to you our new catalogue detailing the lifting, height safety and material handling equipment we supply. We endeavour to supply the highest quality products by being official distributors for European manufacturers such as Gunnebo, Verlinde, JDN, Tractel, Pramac, Pewag and Kito.

This catalogue is designed to give you an overview of our product range and also give you and your team a platform to make an informed decision on which equipment may best suit your application

If required a more detailed product overview including specifications, user guides and data sheets can be found on our website [www.prolift.ie](http://www.prolift.ie).

Our sales team are on hand to answer your calls and we would be more than happy to make a site visit to assist you further with your requirements.

**Darragh Hickey**  
Director

**David McElhinney**  
Director

---



---

Grade 100  
Components



# Quality Assurance

## Type Testing

In order to prove the design, material, heat treatment and method of manufacture, each size of component and chain has been type tested in the finished condition in order to demonstrate that the component and chain possesses the required mechanical properties. The following testing procedures are particularly relevant:

### Test for Deformation

The Manufacturing Proof Force (MPF) for the relevant size of the component is applied and removed. The dimensions after proof loading shall not alter from the original dimensions within the tolerances prescribed in our specifications and in the international standards.

### Static Tensile Test

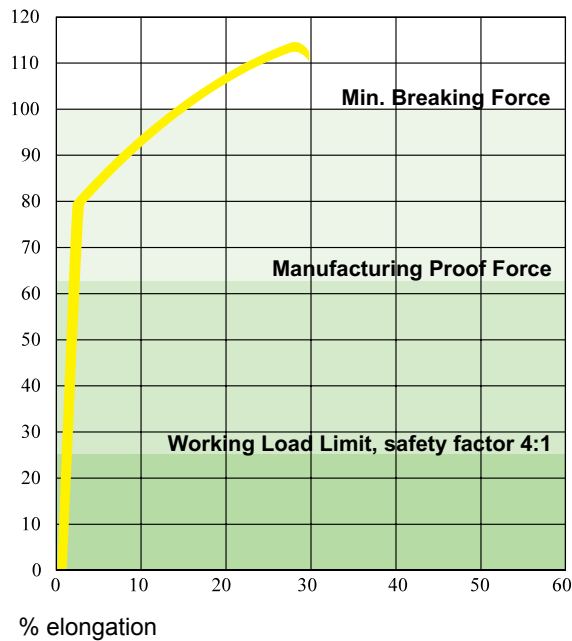
The Breaking Force (BF) for each component and size is verified. The verified value shall be at least equal to the Minimum Breaking Force (MBF) value. The MBF value is equal to the Working Load Limit (WLL) multiplied by the safety factor.

### Fatigue Test

By fatigue testing in pulsator testing machines the toughest conditions of service are simulated.

### Stress / Elongation Diagram

Chain grade 10, type KL  
% of min. Breaking Force



## Manufacturing Testing

During manufacture continuous process tests are carried out according to the requirements in our specifications and in the latest international standards. The following testing procedures are particularly relevant:

### Proof Force

Each individual component and chain link is tested to the Manufacturing Proof Force (MPF) level before delivery. The MPF level is 2.5 times the WLL, equal to 62,5% of the Minimum Breaking Force.

### Non Destructive Test / Visual Inspection

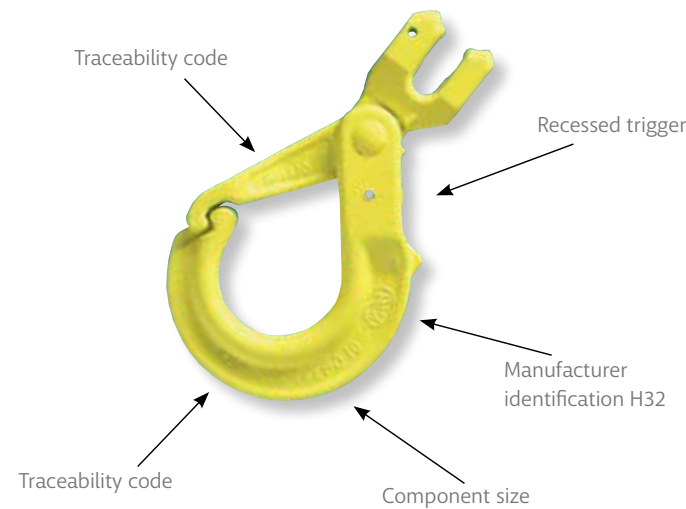
3% of every production batch of forged components are subject to magnetic particle or dye penetrating examination. Visual inspection is carried out on each chain link and each forged component to detect defects.

### Static Tensile and Ultimate Elongation test

During manufacture, samples are tested and the Minimum Breaking Force (MBF) value and the total ultimate elongation are verified.

### Bending Deflection

During manufacturing, of chain and master links, samples are taken and the minimum bend deflection is verified.

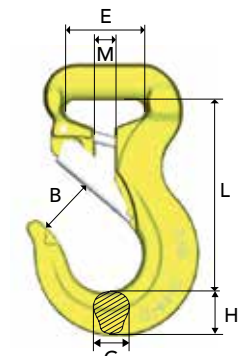
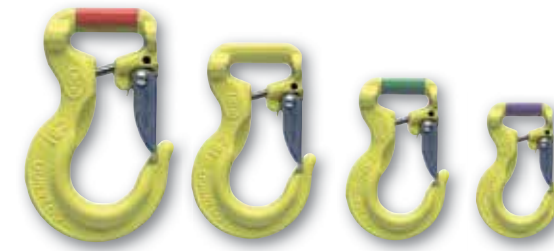


## Roundsling Hook RH

The RH-hook is the perfect load connection solution, combining the advantages of both soft lifting slings and grade 100 components. It can be inserted into a softslings and is quicker and safer to use than the commonly used shackle. The RH-hook is a connector as well as a hook, which gives the user increased flexibility, safer use and increased durability of the soft slings.

The RH-hook comes with a blocking pin, but thanks to the narrow opening it may be used without blocking pin.

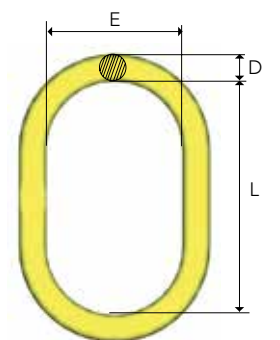
The roundsling hooks are colour coded in order to match the corresponding size of the roundsling: Red=5T / Yellow=3T / Green=2T / Violet=1T



| Art. no. | Code    | WLL tonnes* | B  | E  | G    | L   | H  | M    | Weight kgs |
|----------|---------|-------------|----|----|------|-----|----|------|------------|
| B14490   | RH-1-10 | 1           | 24 | 35 | 16.6 | 84  | 19 | 8    | 0.5        |
| B14491   | RH-2-10 | 2           | 28 | 40 | 17   | 96  | 22 | 10   | 0.7        |
| B14492   | RH-3-10 | 3           | 33 | 47 | 24   | 117 | 30 | 12   | 1.3        |
| B14493   | RH-5-10 | 5           | 43 | 73 | 27   | 155 | 36 | 16.5 | 3.2        |

## Master Link M

| Art. no. | Code        | WLL tonnes (SF 5:1) |            | L   | E   | D  | Weight kgs |
|----------|-------------|---------------------|------------|-----|-----|----|------------|
|          |             | EN 1677-4           | ASTM A-952 |     |     |    |            |
| Z101271  | M-6-10      | 1.5                 | 1.5        | 100 | 60  | 11 | 0.2        |
| Z101272  | M-86-10     | 2.5                 | 3.2        | 125 | 70  | 14 | 0.4        |
| Z101273  | M-108-10    | 4.0                 | 5.2        | 140 | 80  | 17 | 0.8        |
| Z101274  | M-13-10     | 5.4                 | 5.6        | 150 | 90  | 19 | 1.0        |
| Z101267  | M-1310-10   | 7.5                 | 8.0        | 160 | 95  | 22 | 1.5        |
| Z101268  | M-1613-10   | 10.0                | 13.6       | 190 | 110 | 28 | 2.8        |
| Z101247  | M-19-10     | 12.0                | 16.0       | 200 | 120 | 30 | 3.5        |
| Z101269  | M-2016-10   | 17.0                | 20.6       | 240 | 140 | 34 | 5.2        |
| Z101270  | M-2220-10   | 25.0                | 30.9       | 250 | 150 | 40 | 7.3        |
| Z101275  | M-2622-10   | 28.0                | 32.0       | 250 | 150 | 42 | 8.7        |
| Z101284  | M-32-10     | 33.0                | 38.6       | 300 | 180 | 45 | 11.7       |
| Z101276  | M-3226-10   | 43.0                | 46.6       | 300 | 200 | 50 | 14.8       |
| Z101277  | M-3632-10   | 56.0                | 65.0       | 350 | 200 | 55 | 20.7       |
| Z101278  | M-4536-10   | 70.0                | 72.7       | 375 | 210 | 60 | 26.4       |
| Z101279  | M-90T-10    | 90.0                | 100.0      | 450 | 250 | 70 | 42.8       |
| Z101280  | M-125T-10** | 125.0               | 125.0      | 450 | 260 | 80 | 57.0       |



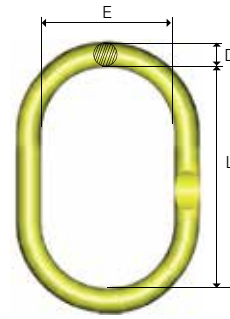
\*\* Dimension L and E not acc. to EN 1677-4.

\*Safety factor 4:1

All dimensions in mm

**Master Link MF** For 1-, 2-, 3- and 4-leg slings. 3- and 4 leg chain slings require CLD / CGD

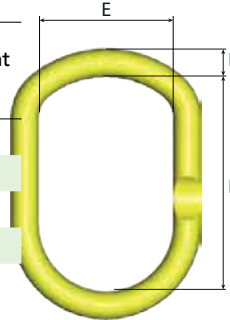
| Art. no. | Code       | WLL tonnes (SF 5:1) |            | For chain size, mm |       |         | L   | E   | D  | Weight kgs |
|----------|------------|---------------------|------------|--------------------|-------|---------|-----|-----|----|------------|
|          |            | EN 1677-4           | ASTM A-952 | 1-leg              | 2-leg | 3-4-leg |     |     |    |            |
| B14487   | MF-6-10    | 1.5                 | 1.5        | 6                  |       |         | 100 | 60  | 11 | 0.2        |
| B14481   | MF-86-10   | 2.5                 | 3.2        | 6, 8               | 6     | -       | 125 | 70  | 14 | 0.4        |
| B14482   | MF-108-10  | 4.0                 | 5.2        | 10                 | 8     | 6       | 140 | 80  | 17 | 0.8        |
| B14483   | MF-1310-10 | 7.5                 | 8.0        | 13                 | 10    | 8       | 160 | 95  | 22 | 1.5        |
| B14484   | MF-1613-10 | 10.0                | 13.6       | 16                 | 13    | 10      | 190 | 110 | 28 | 2.8        |
| B14485   | MF-2016-10 | 17.0                | 20.6       | 20                 | 16    | 13      | 240 | 140 | 34 | 5.2        |
| B14486   | MF-2220-10 | 25.0                | 30.9       | 22                 | 20    | 16      | 250 | 150 | 40 | 7.3        |



**Master Link MFH**

Designed for crane hooks, DIN 15401. 3- and 4 leg chain slings require CLD / CGD

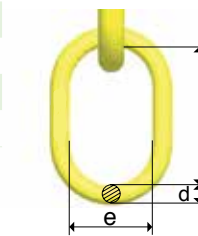
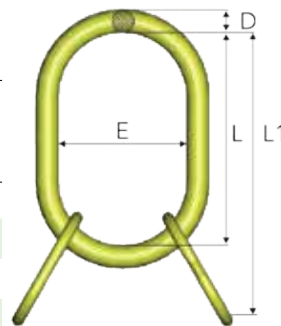
| Art. no. | Code         | WLL tonnes (SF 5:1) |            | For chain size, mm |       |         | L   | E   | D  | DIN 15401 | DIN 15402 | Weight kgs |
|----------|--------------|---------------------|------------|--------------------|-------|---------|-----|-----|----|-----------|-----------|------------|
|          |              | EN 1677-4           | ASTM A-952 | 1-leg              | 2-leg | 3-4 leg |     |     |    |           |           |            |
| Z101262  | MFH-1310-10  | 7.5                 | 8.0        | 13                 | 10    | 8       | 230 | 125 | 22 | ≤ 12      | ≤ 16      | 1.9        |
| Z101263  | MFH-1613-10  | 10                  | 13.6       | 16                 | 13    | 10      | 250 | 135 | 28 | ≤ 12      | ≤ 16      | 3.2        |
| Z101264  | MFH-2016-10  | 17                  | 20.6       | 20                 | 16    | 13      | 280 | 135 | 32 | ≤ 16      | ≤ 20      | 4.6        |
| Z101265  | MFH-2220-10  | 28                  | 30.9       | 22                 | 20    | 16      | 320 | 175 | 40 | ≤ 25      | ≤ 32      | 8.6        |
| Z101266  | MFHW-2220-10 | 25                  | 30.9       | 22                 | 20    | 16      | 355 | 225 | 40 | ≤ 50      | ≤ 63      | 9.9        |



**Master Link with Sublinks, MT**

Designed for use with chain or wire rope. For 3- and 4-leg slings.

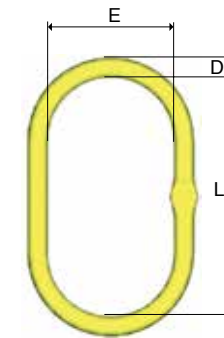
| Art. no. | Code     | WLL tonnes (SF 5:1) |            | L1  | L   | E   | D  | I   | e   | d  | Weight kgs |
|----------|----------|---------------------|------------|-----|-----|-----|----|-----|-----|----|------------|
|          |          | EN 1677-4           | ASTM A-952 |     |     |     |    |     |     |    |            |
| Z100902  | MT-6-10  | 3.5                 | 5.0        | 270 | 150 | 90  | 19 | 120 | 70  | 14 | 1.8        |
| Z100903  | MT-8-10  | 5.2                 | 8.0        | 300 | 160 | 95  | 22 | 140 | 80  | 17 | 3.0        |
| Z101359  | MT-9-10  | 6.9                 | 9.7        | 340 | 190 | 110 | 28 | 150 | 90  | 19 | 4.9        |
| Z100904  | MT-10-10 | 11.5                | 16.0       | 360 | 200 | 120 | 30 | 160 | 95  | 22 | 6.4        |
| Z100905  | MT-13-10 | 17.0                | 26.0       | 450 | 250 | 150 | 40 | 190 | 110 | 28 | 14.2       |
| Z100906  | MT-16-10 | 28.0                | 35.0       | 500 | 300 | 200 | 50 | 200 | 120 | 32 | 23         |
| Z101074  | MT-20-10 | 35.0                | 50.0       | 550 | 300 | 200 | 55 | 250 | 150 | 40 | 31.5       |
| Z101281  | MT-22-10 | 53.0                | 75.0       | 610 | 350 | 200 | 60 | 260 | 140 | 45 | 46         |
| Z101282  | MT-26-10 | 70.0                | 100.0      | 730 | 450 | 250 | 70 | 280 | 160 | 50 | 71         |



All dimensions in mm

**Master Link, MFX** Oversized, for 1- and 2-leg slings.

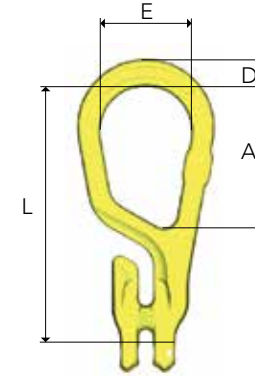
| Art. no. | Code        | WLL tonnes (SF 5:1) |            | For chain 1-leg | For chain 2-leg | L   | E   | D  | Weight kgs |
|----------|-------------|---------------------|------------|-----------------|-----------------|-----|-----|----|------------|
|          |             | EN 1677-4           | ASTM A-952 |                 |                 |     |     |    |            |
| Z100550  | MFX-108-10  | 4.25                | 5.2        | 8, 10           | 8               | 340 | 180 | 25 | 3.7        |
| Z100551  | MFX-1310-10 | 7.5                 | 8.0        | 13              | 10              | 340 | 180 | 28 | 4.7        |
| Z100552  | MFX-1613-10 | 11.2                | 13.6       | 16              | 13              | 340 | 180 | 34 | 7.1        |
| Z101125  | MFX-2016-10 | 16.0                | 20.6       | 20              | 16              | 340 | 180 | 40 | 9.6        |



Designed for use with CL, CLD, CG and CGD.

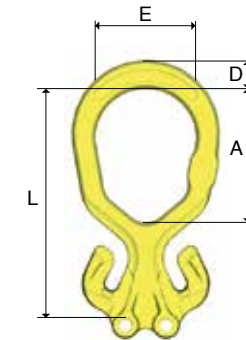
**Master Grab MG** "All-in-one" compact top link.

| Art. no. | Code     | WLL tonnes* | L   | A   | E   | D  | Weight kgs |
|----------|----------|-------------|-----|-----|-----|----|------------|
| B14710   | MG-6-10  | 1.5         | 145 | 88  | 60  | 15 | 0.5        |
| B14711   | MG-8-10  | 2.5         | 171 | 92  | 60  | 18 | 0.9        |
| B14712   | MG-10-10 | 4.0         | 211 | 113 | 75  | 22 | 1.8        |
| B14713   | MG-13-10 | 6.7         | 261 | 138 | 90  | 26 | 3.5        |
| B14714   | MG-16-10 | 10.0        | 311 | 157 | 105 | 31 | 6.1        |



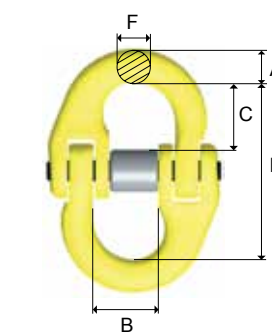
**Master Grab Duo MGD** "All-in-one" compact top link for 2-leg slings.

| Art. no. | Code      | WLL tonnes* | L   | A   | E   | D  | Weight kgs |
|----------|-----------|-------------|-----|-----|-----|----|------------|
| B14700   | MGD-6-10  | 2.1         | 144 | 90  | 60  | 17 | 0.7        |
| B14701   | MGD-8-10  | 3.5         | 171 | 100 | 75  | 21 | 1.3        |
| B14702   | MGD-10-10 | 5.6         | 211 | 124 | 90  | 24 | 2.3        |
| B14703   | MGD-13-10 | 9.5         | 262 | 149 | 105 | 31 | 5.2        |
| B14704   | MGD-16-10 | 14.0        | 310 | 175 | 120 | 35 | 7.9        |



**Coupling Link G**

| Art. no. | Code    | WLL tonnes* | L   | B  | F  | A  | C  | Weight kgs |
|----------|---------|-------------|-----|----|----|----|----|------------|
| Z100821  | G-6-10  | 1.5         | 45  | 15 | 7  | 8  | 16 | 0.1        |
| Z101358  | G-7-10  | 2.0         | 56  | 18 | 9  | 11 | 22 | 0.2        |
| Z100822  | G-8-10  | 2.5         | 56  | 18 | 9  | 11 | 22 | 0.2        |
| Z100823  | G-10-10 | 4.0         | 68  | 25 | 12 | 13 | 26 | 0.3        |
| Z100824  | G-13-10 | 6.7         | 89  | 29 | 15 | 17 | 33 | 0.7        |
| Z100825  | G-16-10 | 10.0        | 106 | 36 | 19 | 20 | 40 | 1.4        |
| Z101119  | G-20-10 | 16.0        | 125 | 43 | 23 | 26 | 44 | 2.2        |
| Z101339  | G-22-10 | 20.0        | 152 | 50 | 26 | 28 | 59 | 3.5        |
| Z101365  | G-26-10 | 27.0        | 161 | 58 | 32 | 34 | 61 | 5.7        |



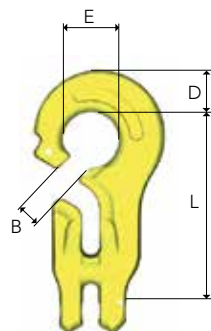
For larger sizes, see Classic Grade 8

\*Safety factor 4:1

All dimensions in mm

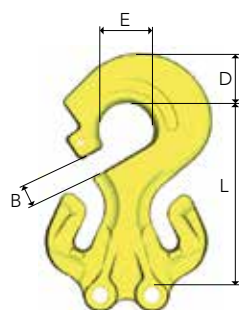
**C-Grab CG** For use with master link, eye hooks and choke.

| Art. no. | Code     | WLL tonnes* | L   | B  | E  | D  | Weight kgs |
|----------|----------|-------------|-----|----|----|----|------------|
| B14730   | CG-6-10  | 1.5         | 80  | 11 | 24 | 19 | 0.3        |
| B14731   | CG-8-10  | 2.5         | 107 | 12 | 32 | 24 | 0.7        |
| B14732   | CG-10-10 | 4.0         | 134 | 15 | 40 | 29 | 1.5        |
| B14733   | CG-13-10 | 6.7         | 172 | 18 | 52 | 38 | 3.2        |
| B14734   | CG-16-10 | 10.0        | 215 | 22 | 64 | 47 | 6.1        |



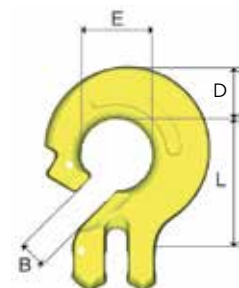
**C-Grab CGD** For use with master links.

| Art. no. | Code      | WLL tonnes* | L   | B  | E  | D  | Weight kgs |
|----------|-----------|-------------|-----|----|----|----|------------|
| B14720   | CGD-6-10  | 2.1         | 79  | 11 | 24 | 20 | 0.6        |
| B14721   | CGD-8-10  | 3.5         | 107 | 12 | 32 | 29 | 1.1        |
| B14722   | CGD-10-10 | 5.6         | 134 | 15 | 40 | 37 | 2.2        |
| B14723   | CGD-13-10 | 9.5         | 173 | 19 | 48 | 48 | 5.4        |
| B14724   | CGD-16-10 | 14.0        | 215 | 22 | 64 | 57 | 9.1        |



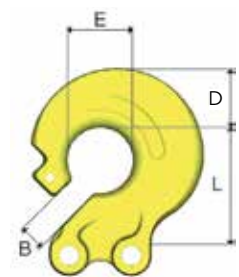
**C-Lok CL** For use with master links, eye hooks and choke.

| Art. no. | Code     | WLL tonnes* | L   | B  | E  | D  | Weight kgs |
|----------|----------|-------------|-----|----|----|----|------------|
| B14750   | CL-6-10  | 1.5         | 43  | 11 | 24 | 18 | 0.2        |
| B14751   | CL-8-10  | 2.5         | 58  | 12 | 32 | 24 | 0.5        |
| B14752   | CL-10-10 | 4.0         | 74  | 15 | 40 | 29 | 1.0        |
| B14753   | CL-13-10 | 6.7         | 94  | 18 | 52 | 38 | 2.0        |
| B14754   | CL-16-10 | 10.0        | 119 | 22 | 64 | 48 | 3.8        |



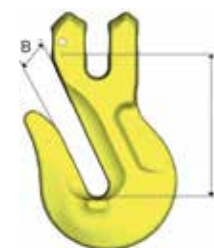
**C-Lok CLD** For use with master links.

| Art. no. | Code      | WLL tonnes* | L   | B  | E  | D  | Weight kgs |
|----------|-----------|-------------|-----|----|----|----|------------|
| B14740   | CLD-6-10  | 2.1         | 43  | 11 | 24 | 22 | 0.4        |
| B14741   | CLD-8-10  | 3.5         | 58  | 12 | 32 | 29 | 0.6        |
| B14742   | CLD-10-10 | 5.6         | 74  | 15 | 40 | 37 | 1.2        |
| B14743   | CLD-13-10 | 9.5         | 94  | 18 | 52 | 46 | 3.1        |
| B14744   | CLD-16-10 | 14.0        | 119 | 25 | 64 | 57 | 5.5        |



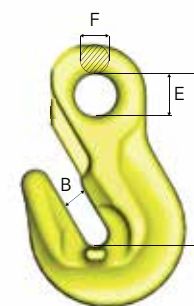
**Grab Hook GG**

| Art. no. | Code     | WLL tonnes* | L   | B    | Weight kgs |
|----------|----------|-------------|-----|------|------------|
| Z100845  | GG-7-10  | 2.0         | 57  | 10   | 0.3        |
| B14771   | GG-8-10  | 2.5         | 57  | 10.5 | 0.4        |
| B14772   | GG-10-10 | 4.0         | 76  | 12   | 0.9        |
| B14773   | GG-13-10 | 6.7         | 97  | 16   | 1.8        |
| B14774   | GG-16-10 | 10.0        | 124 | 20   | 3.1        |
| Z101152  | GG-20-10 | 16.0        | 147 | 26   | 7.0        |



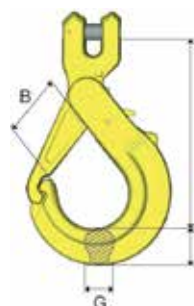
**Grab Hook OG**

| Art. no. | Code      | WLL tonnes* | L   | B    | E  | F  | Weight kgs |
|----------|-----------|-------------|-----|------|----|----|------------|
| Z101296  | OG-7/8-10 | 2.5         | 65  | 10.5 | 17 | 12 | 0.3        |
| Z101297  | OG-10-10  | 4.0         | 85  | 12   | 20 | 16 | 0.7        |
| Z101298  | OG-13-10  | 6.7         | 104 | 16.2 | 26 | 22 | 1.6        |
| Z101299  | OG-16-10  | 10.0        | 131 | 20   | 32 | 24 | 2.8        |
| Z101300  | OG-20-10  | 16.0        | 167 | 26.4 | 41 | 28 | 6.1        |
| Z101301  | OG-22-10  | 20.0        | 187 | 26   | 46 | 32 | 8.6        |
| Z101302  | OG-26-10  | 27.0        | 228 | 32   | 55 | 38 | 14         |



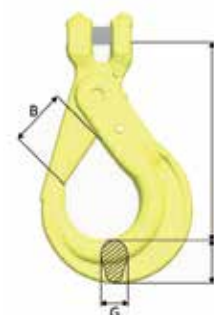
**Safety Hook GBK**

| Art. no. | Code      | WLL tonnes* | L   | B  | G  | H  | Weight kgs |
|----------|-----------|-------------|-----|----|----|----|------------|
| Z100758  | GBK-6-10  | 1.5         | 87  | 26 | 15 | 17 | 0.4        |
| Z100849  | GBK-7-10  | 2.0         | 114 | 36 | 20 | 22 | 0.5        |
| Z100759  | GBK-8-10  | 2.5         | 119 | 36 | 20 | 22 | 0.8        |
| Z100760  | GBK-10-10 | 4.0         | 150 | 47 | 22 | 29 | 1.4        |
| Z100761  | GBK-13-10 | 6.7         | 172 | 53 | 29 | 38 | 2.7        |
| Z100762  | GBK-16-10 | 10.0        | 208 | 68 | 30 | 45 | 4.4        |



**Safety Hook BKG**

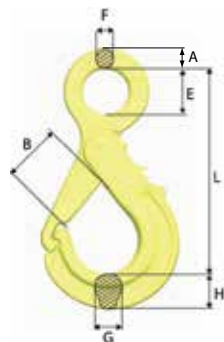
| Art. no. | Code      | WLL tonnes* | L   | B  | G  | H  | Weight kgs |
|----------|-----------|-------------|-----|----|----|----|------------|
| Z101110  | BKG-6-10  | 1.5         | 91  | 29 | 15 | 21 | 0.5        |
| Z101098  | BKG-7-10  | 2.0         | 120 | 37 | 17 | 22 | 0.5        |
| Z101100  | BKG-8-10  | 2.5         | 121 | 37 | 17 | 26 | 0.9        |
| Z101026  | BKG-10-10 | 4.0         | 144 | 45 | 21 | 31 | 1.5        |
| Z101034  | BKG-13-10 | 6.7         | 180 | 55 | 30 | 40 | 3.0        |
| Z101042  | BKG-16-10 | 10.0        | 219 | 62 | 37 | 50 | 5.5        |
| Z101091  | BKG-20-10 | 16.0        | 240 | 68 | 44 | 62 | 9.6        |





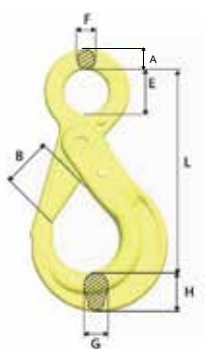
### Safety Hook OBK

| Art. no. | Code         | WLL tonnes* | A  | L   | B  | E  | F  | G  | H  | Weight kgs |
|----------|--------------|-------------|----|-----|----|----|----|----|----|------------|
| Z101048  | OBK-6-10     | 1.5         | 12 | 103 | 26 | 22 | 9  | 15 | 17 | 0.4        |
| Z101143  | OBK-7/8-10   | 2.5         | 14 | 139 | 37 | 28 | 10 | 20 | 22 | 0.8        |
| Z101145  | OBK-10-10    | 4.0         | 16 | 170 | 47 | 34 | 13 | 22 | 29 | 1.3        |
| Z101147  | OBK-13-10    | 6.7         | 21 | 206 | 53 | 44 | 15 | 29 | 38 | 2.6        |
| Z101141  | OBK-16-10    | 10.0        | 26 | 251 | 68 | 56 | 19 | 29 | 45 | 4.4        |
| Z101240  | OBK-18/20-10 | 16.0        | 28 | 293 | 74 | 60 | 22 | 44 | 56 | 7.3        |



### Safety Hook BK

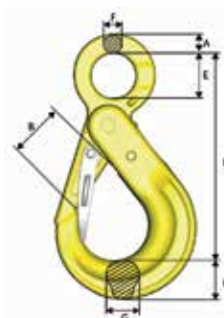
| Art. no. | Code        | WLL tonnes* | A  | L   | B   | E  | F  | G  | H  | Weight kgs |
|----------|-------------|-------------|----|-----|-----|----|----|----|----|------------|
| Z101108  | BK-6-10     | 1.5         | 12 | 109 | 29  | 22 | 10 | 15 | 21 | 0.5        |
| Z101097  | BK-7/8-10   | 2.5         | 14 | 138 | 37  | 28 | 11 | 17 | 26 | 0.9        |
| Z101024  | BK-10-10    | 4.0         | 16 | 168 | 45  | 34 | 13 | 21 | 31 | 1.5        |
| Z101032  | BK-13-10    | 6.7         | 20 | 207 | 55  | 44 | 16 | 30 | 40 | 3.0        |
| Z101040  | BK-16-10    | 10.0        | 26 | 254 | 62  | 56 | 20 | 37 | 50 | 5.5        |
| Z101089  | BK-18/20-10 | 16.0        | 30 | 289 | 68  | 60 | 22 | 44 | 62 | 9.0        |
| Z101325  | BK-22-10    | 20.0        | 32 | 320 | 80  | 70 | 24 | 50 | 62 | 11.3       |
| Z101326  | BK-26-10    | 27.0        | 35 | 342 | 100 | 80 | 25 | 54 | 68 | 16.5       |



For larger sizes, see Classic Grade 8

### Safety Hook BKD The double latch BK-hook with recessed trigger.

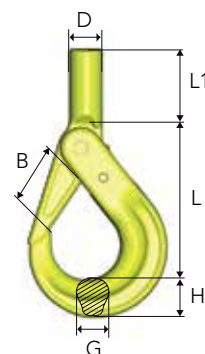
| Art. no. | Code         | WLL tonnes* | A  | L   | B  | E  | F  | G  | H  | Weight kgs |
|----------|--------------|-------------|----|-----|----|----|----|----|----|------------|
| Z101154  | BKD-13-10    | 6.7         | 20 | 207 | 44 | 44 | 16 | 30 | 40 | 3.2        |
| Z101155  | BKD-16-10    | 10.0        | 26 | 254 | 48 | 56 | 20 | 37 | 50 | 5.8        |
| Z101156  | BKD-18/20-10 | 16.0        | 30 | 289 | 57 | 60 | 22 | 44 | 62 | 9.1        |
| Z101373  | BKD-26-10 OS | 27.0        | 35 | 342 | 72 | 80 | 25 | 50 | 69 | 14.5       |



### Shank Safety Hook BKT

| Art. no. | Code       | WLL tonnes* | L   | B  | L1 | D  | dmin | G  | H  | Weight kgs |
|----------|------------|-------------|-----|----|----|----|------|----|----|------------|
| Z1011120 | BKT-6-10   | 1.5         | 90  | 29 | 36 | 20 | 11   | 15 | 21 | 0.5        |
| Z1011020 | BKT-7/8-10 | 2.5         | 111 | 37 | 47 | 24 | 13   | 17 | 26 | 0.9        |
| Z1010690 | BKT-10-10  | 4.0         | 133 | 45 | 51 | 29 | 16   | 21 | 31 | 1.6        |

d min = the smallest permitted shank dimension after machining.  
Note! After machining of the shank, proof loading must be carried out.

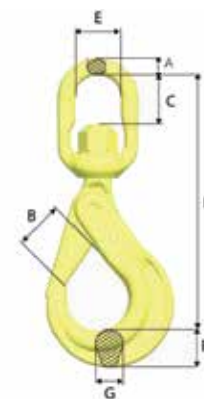


\*Safety factor 4:1

All dimensions in mm

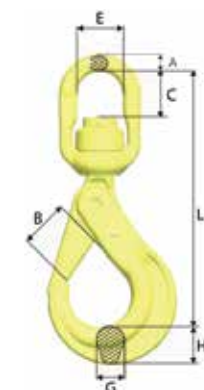
### Swivel Safety Hook BKL

| Art. no. | Code         | WLL tonnes* | L   | B  | C  | E  | A  | G  | H  | Weight kgs |
|----------|--------------|-------------|-----|----|----|----|----|----|----|------------|
| Z101114  | BKL-6-10     | 1.5         | 149 | 29 | 23 | 33 | 11 | 15 | 21 | 0.7        |
| Z101104  | BKL-7/8-10   | 2.5         | 183 | 37 | 27 | 38 | 12 | 17 | 26 | 1.2        |
| Z101028  | BKL-10-10    | 4.0         | 218 | 45 | 37 | 44 | 15 | 21 | 31 | 2.0        |
| Z101036  | BKL-13-10    | 6.7         | 282 | 55 | 49 | 48 | 19 | 30 | 40 | 4.0        |
| Z101044  | BKL-16-10    | 10.0        | 341 | 62 | 65 | 61 | 25 | 37 | 50 | 7.2        |
| Z101093  | BKL-18/20-10 | 16.0        | 368 | 68 | 70 | 72 | 31 | 44 | 62 | 11.4       |



### Swivel Safety Hook BKLK with ball-bearing

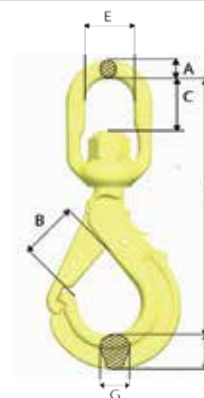
| Art. no. | Code          | WLL tonnes* | L   | B   | C   | E   | A  | G  | H  | Weight kgs |
|----------|---------------|-------------|-----|-----|-----|-----|----|----|----|------------|
| Z101116  | BKLN-6-10     | 1.5         | 149 | 29  | 24  | 33  | 11 | 15 | 21 | 0.7        |
| Z101106  | BKLN-7/8-10   | 2.5         | 183 | 37  | 27  | 38  | 12 | 17 | 26 | 1.2        |
| Z101030  | BKLN-10-10    | 4.0         | 218 | 45  | 35  | 44  | 15 | 21 | 31 | 2.0        |
| Z101038  | BKLN-13-10    | 6.7         | 280 | 55  | 45  | 48  | 19 | 30 | 40 | 4.0        |
| Z101046  | BKLN-16-10    | 10.0        | 339 | 62  | 62  | 61  | 25 | 37 | 50 | 7.4        |
| Z101095  | BKLN-18/20-10 | 16.0        | 368 | 68  | 60  | 72  | 31 | 44 | 62 | 11.5       |
| Z101294  | BKLN-22-10 OS | 20.0        | 436 | 79  | 80  | 80  | 35 | 50 | 62 | 16.8       |
| Z101295  | BKLN-26-10 OS | 27.0        | 486 | 100 | 110 | 102 | 45 | 54 | 68 | 26         |



For larger sizes, see Classic Grade 8

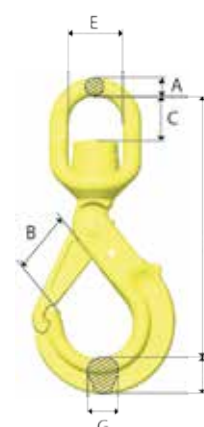
### Swivel Safety Hook with Griplatch LBK

| Art. no. | Code       | WLL tonnes* | L   | B  | C  | E  | A  | G  | H  | Weight kgs |
|----------|------------|-------------|-----|----|----|----|----|----|----|------------|
| Z100978  | LBK-7/8-10 | 2.5         | 177 | 37 | 27 | 38 | 12 | 20 | 22 | 1.1        |
| Z100960  | LBK-10-10  | 4.0         | 214 | 47 | 37 | 44 | 15 | 22 | 29 | 1.8        |
| Z100993  | LBK-13-10  | 6.7         | 262 | 53 | 45 | 48 | 19 | 29 | 38 | 3.5        |
| Z100995  | LBK-16-10  | 10.0        | 324 | 68 | 66 | 61 | 25 | 30 | 45 | 5.9        |



### Swivel Safety Hook with Griplatch LKBK with ball-bearing

| Art. no. | Code        | WLL tonnes* | L   | B  | C  | E  | A  | G  | H  | Weight kgs |
|----------|-------------|-------------|-----|----|----|----|----|----|----|------------|
| Z100980  | LKBK-7/8-10 | 2.5         | 176 | 37 | 27 | 38 | 12 | 20 | 22 | 1.1        |
| Z100962  | LKBK-10-10  | 4.0         | 213 | 47 | 35 | 44 | 15 | 22 | 29 | 1.9        |
| Z100997  | LKBK-13-10  | 6.7         | 261 | 53 | 43 | 48 | 19 | 29 | 38 | 3.6        |
| Z100999  | LKBK-16-10  | 10.0        | 323 | 68 | 61 | 61 | 25 | 30 | 45 | 6.2        |



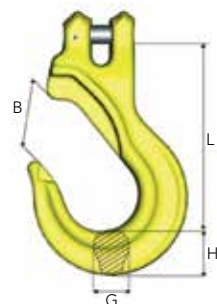
\*Safety factor 4:1

All dimensions in mm



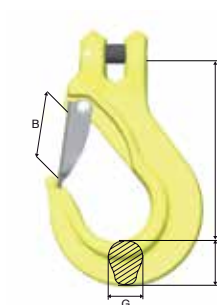
### Sling Hook EGK

| Art. no. | Code      | WLL tonnes* | L   | B  | G  | H  | Weight kgs |
|----------|-----------|-------------|-----|----|----|----|------------|
| Z100915  | EGK-6-10  | 1.5         | 86  | 28 | 17 | 20 | 0.4        |
| Z100918  | EGK-7-10  | 2.0         | 95  | 32 | 17 | 22 | 0.5        |
| Z100938  | EGK-8-10  | 2.5         | 95  | 32 | 17 | 23 | 0.5        |
| Z100942  | EGK-10-10 | 4.0         | 121 | 41 | 23 | 31 | 1.0        |
| Z100946  | EGK-13-10 | 6.7         | 145 | 49 | 28 | 38 | 2.0        |
| Z100950  | EGK-16-10 | 10.0        | 170 | 61 | 36 | 46 | 3.8        |
| Z101138  | EGK-20-10 | 16.0        | 209 | 70 | 42 | 60 | 7.3        |



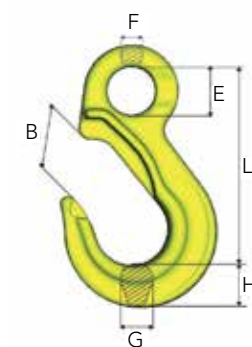
### Sling Hook EGKN with latch

| Art. no. | Code       | WLL tonnes* | L   | B    | G  | H  | Weight kgs |
|----------|------------|-------------|-----|------|----|----|------------|
| B14460   | EGKN-6-10  | 1.5         | 86  | 24,5 | 17 | 20 | 0.4        |
| Z100843  | EGKN-7-10  | 2.0         | 95  | 28   | 17 | 23 | 0.5        |
| B14461   | EGKN-8-10  | 2.5         | 95  | 28   | 17 | 23 | 0.5        |
| B14462   | EGKN-10-10 | 4.0         | 121 | 35   | 23 | 31 | 1.1        |
| B14463   | EGKN-13-10 | 6.7         | 145 | 42   | 28 | 38 | 2.2        |
| B14464   | EGKN-16-10 | 10.0        | 170 | 52   | 36 | 46 | 4.0        |
| Z101127  | EGKN-20-10 | 16.0        | 209 | 61   | 42 | 60 | 7.6        |



### Sling Hook EK

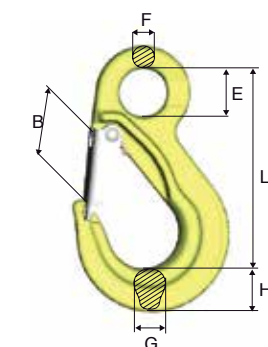
| Art. no. | Code     | WLL tonnes* | L   | B  | E  | F  | G  | H  | Weight kgs |
|----------|----------|-------------|-----|----|----|----|----|----|------------|
| Z101162  | EK- 6-10 | 1.5         | 94  | 29 | 22 | 10 | 17 | 20 | 0.4        |
| Z101164  | EK- 8-10 | 2.5         | 109 | 32 | 28 | 12 | 17 | 23 | 0.5        |
| Z101166  | EK-10-10 | 4.0         | 134 | 42 | 34 | 14 | 23 | 30 | 0.9        |
| Z101168  | EK-13-10 | 6.7         | 166 | 49 | 44 | 18 | 28 | 38 | 2.0        |
| Z101170  | EK-16-10 | 10.0        | 203 | 60 | 56 | 22 | 36 | 47 | 3.8        |
| Z101306  | EK-20-10 | 16.0        | 229 | 71 | 61 | 26 | 42 | 60 | 6.3        |
| Z101307  | EK-22-10 | 20.0        | 267 | 83 | 64 | 31 | 43 | 67 | 8.5        |
| Z101308  | EK-26-10 | 27.0        | 301 | 95 | 66 | 32 | 51 | 75 | 12.6       |



For larger sizes, see Classic Grade 8

### Sling Hook EKN with latch

| Art. no. | Code      | WLL tonnes* | L   | B  | E  | F  | G  | H  | Weight kgs |
|----------|-----------|-------------|-----|----|----|----|----|----|------------|
| Z101128  | EKN- 6-10 | 1.5         | 94  | 24 | 22 | 10 | 17 | 20 | 0.4        |
| Z101130  | EKN- 8-10 | 2.5         | 108 | 28 | 28 | 12 | 17 | 23 | 0.5        |
| Z101132  | EKN-10-10 | 4.0         | 134 | 37 | 34 | 14 | 23 | 30 | 1          |
| Z101134  | EKN-13-10 | 6.7         | 166 | 42 | 44 | 18 | 28 | 38 | 2.1        |
| Z101136  | EKN-16-10 | 10.0        | 203 | 50 | 56 | 22 | 36 | 47 | 3.9        |
| Z101327  | EKN-20-10 | 16.0        | 229 | 60 | 61 | 26 | 42 | 60 | 6.3        |
| Z101328  | EKN-22-10 | 20.0        | 267 | 73 | 64 | 31 | 43 | 67 | 8.7        |
| Z101329  | EKN-26-10 | 27.0        | 301 | 82 | 66 | 32 | 51 | 75 | 13.2       |



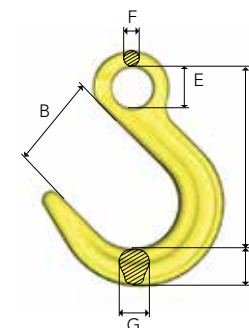
For larger sizes, see Classic Grade 8

\*Safety factor 4:1

All dimensions in mm

### Foundry Hook OKE

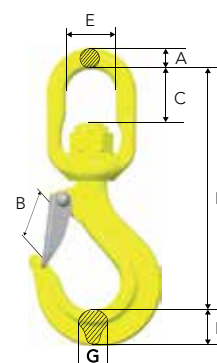
| Art. no. | Code       | WLL tonnes* | L   | B   | E  | F  | G  | H  | Weight kgs |
|----------|------------|-------------|-----|-----|----|----|----|----|------------|
| Z100853  | OKE-7/8-10 | 2.5         | 124 | 63  | 28 | 12 | 21 | 26 | 0.8        |
| Z100854  | OKE-10-10  | 4.0         | 151 | 76  | 34 | 15 | 26 | 30 | 1.4        |
| Z100855  | OKE-13-10  | 6.7         | 184 | 90  | 44 | 19 | 33 | 39 | 2.8        |
| Z100898  | OKE-16-10  | 10.0        | 218 | 102 | 56 | 23 | 40 | 46 | 4.9        |
| Z101340  | OKE-20-10  | 16.0        | 247 | 114 | 60 | 27 | 46 | 60 | 7.2        |
| Z101341  | OKE-22-10  | 20.0        | 275 | 120 | 64 | 31 | 60 | 70 | 11.3       |
| Z101342  | OKE-26-10  | 27.0        | 300 | 113 | 70 | 35 | 64 | 77 | 16         |



For larger sizes, see Classic Grade 8

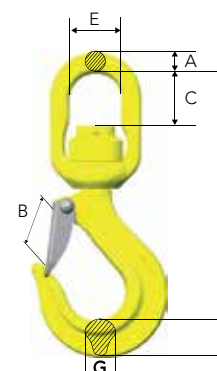
### Swivel Latch Hook LKN

| Art. no. | Code       | WLL tonnes* | For chain dim. mm | L   | B  | C  | E  | A  | G  | H  | Weight appr. kgs |
|----------|------------|-------------|-------------------|-----|----|----|----|----|----|----|------------------|
| Z101345  | LKN-7/8-10 | 2.5         | 7, 8              | 155 | 28 | 28 | 38 | 12 | 18 | 24 | 0.8              |
| Z101346  | LKN-10-10  | 4.0         | 10                | 192 | 35 | 37 | 44 | 15 | 23 | 31 | 1.5              |
| Z101347  | LKN-13-10  | 6.7         | 13                | 238 | 40 | 47 | 48 | 19 | 28 | 38 | 3.1              |
| Z101348  | LKN-16-10  | 10.0        | 16                | 295 | 53 | 65 | 61 | 25 | 34 | 43 | 5.3              |



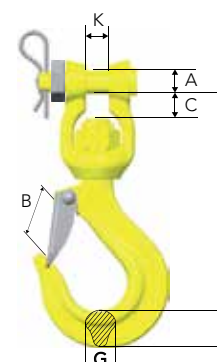
### Swivel Latch Hook LKNK with ball bearing

| Art. no. | Code        | WLL tonnes* | For chain dim. | L   | B  | C  | E  | A  | G  | H  | Weight appr. kgs |
|----------|-------------|-------------|----------------|-----|----|----|----|----|----|----|------------------|
| Z101349  | LKNK-7/8-10 | 2.5         | 7, 8           | 154 | 28 | 28 | 38 | 12 | 18 | 24 | 0.9              |
| Z101350  | LKNK-10-10  | 4.0         | 10             | 191 | 35 | 35 | 44 | 15 | 23 | 31 | 1.6              |
| Z101351  | LKNK-13-10  | 6.7         | 13             | 236 | 40 | 45 | 48 | 19 | 28 | 38 | 3.3              |
| Z101352  | LKNK-16-10  | 10.0        | 16             | 293 | 53 | 62 | 61 | 25 | 34 | 43 | 5.6              |



### Clevis Swivel Hook LKNG

| Art. no. | Code       | WLL tonnes* | For chain dim. | L   | B  | C  | A  | G  | H  | K  | Weight appr. kgs |
|----------|------------|-------------|----------------|-----|----|----|----|----|----|----|------------------|
| Z101353  | LKNG-16-10 | 10.0        | 16             | 258 | 53 | 30 | 28 | 34 | 43 | 27 | 5.7              |

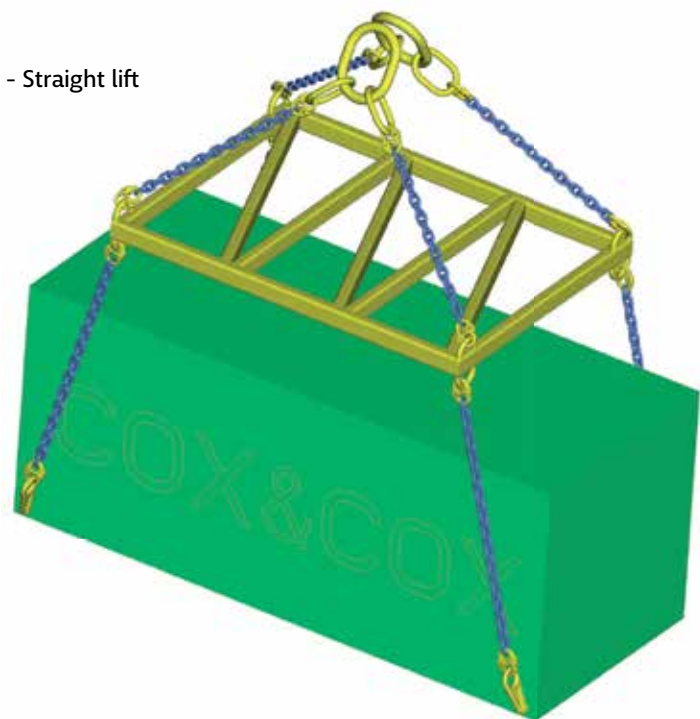


\*Safety factor 4:1

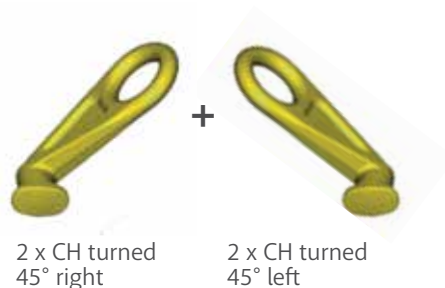
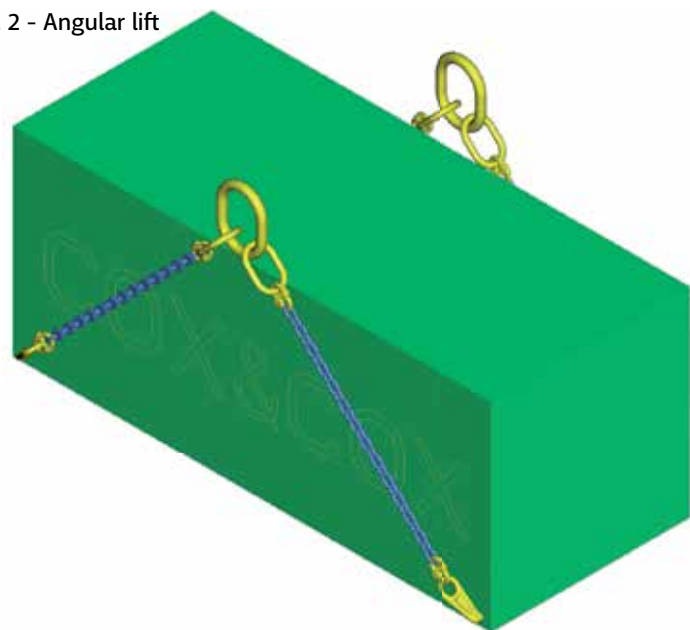
All dimensions in mm

**Container Hook CH** Made for lifting containers in their lower fittings.

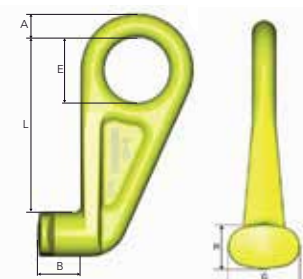
Alt. 1 - Straight lift



Alt. 2 - Angular lift



| Art. no. | Code            | WLL tonnes* | A  | L   | E  | B  | H  | G  | Weight kgs |
|----------|-----------------|-------------|----|-----|----|----|----|----|------------|
| Z101220  | CH-3            | 12.5        | 25 | 187 | 70 | 46 | 47 | 75 | 3.8        |
| Z101221  | CH-3, 45° left  | 12.5        | 25 | 187 | 70 | 46 | 47 | 75 | 3.8        |
| Z101219  | CH-3, 45° right | 12.5        | 25 | 187 | 70 | 46 | 47 | 75 | 3.8        |



**Notes**

---

---

---

---

---

---

---

---

---

---

---

---

---

---

---

---

---

---

---

---

---

---

---

---

---

---

\*Safety factor 4:1

All dimensions in mm

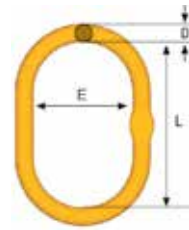


---

Grade 80  
Components

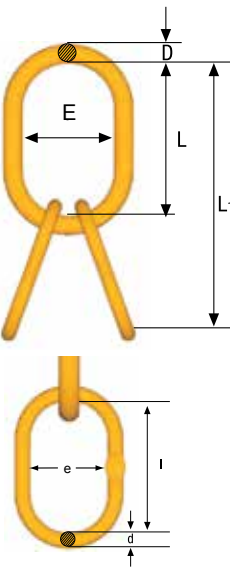
**Master Link MF** EN 1677-4

| Art. no. | Code       | WLL (SF 5:1) tonnes* |            | L   | E   | D  | Weight kgs |
|----------|------------|----------------------|------------|-----|-----|----|------------|
|          |            | EN 1677-4            | ASTM A-952 |     |     |    |            |
| Z100860  | MF-86-10   | 2.5                  | 3.2        | 125 | 70  | 14 | 0.4        |
| Z100861  | MF-108-10  | 4.0                  | 5.2        | 140 | 80  | 17 | 0.8        |
| Z100862  | MF-1310-10 | 7.5                  | 8.0        | 160 | 95  | 22 | 1.5        |
| Z100863  | MF-1613-10 | 10.0                 | 13.6       | 190 | 110 | 28 | 2.5        |
| Z100864  | MF-2016-10 | 17.0                 | 20.6       | 240 | 140 | 34 | 5.2        |
| Z100865  | MF-2220-10 | 25.0                 | 30.9       | 250 | 150 | 40 | 7.3        |



**Master Link with Sub Links MT** EN 1677-4

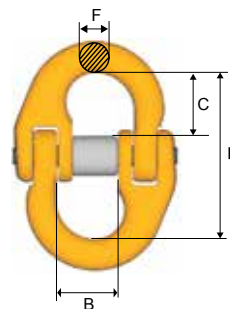
| Art. no. | Code       | WLL (SF 5:1) tonnes* |            | For chain 3-4-leg | L1  | L   | E   | D  | I   | e   | d  | Weight kgs |
|----------|------------|----------------------|------------|-------------------|-----|-----|-----|----|-----|-----|----|------------|
|          |            | EN 1677-4            | ASTM A-952 |                   |     |     |     |    |     |     |    |            |
| Z100888  | MT-6-10**  | 3.5                  | 5.0        | 6                 | 270 | 150 | 90  | 19 | 120 | 70  | 14 | 1.8        |
| Z100889  | MT-8-10**  | 5.2                  | 8.0        | 7, 8              | 300 | 160 | 95  | 22 | 140 | 80  | 17 | 3          |
| Z100890  | MT-10-10** | 11.5                 | 16.0       | 10                | 360 | 200 | 120 | 30 | 160 | 95  | 22 | 6.4        |
| Z100891  | MT-13-10** | 17.0                 | 26.0       | 13                | 450 | 250 | 150 | 40 | 200 | 120 | 30 | 14.2       |
| Z100892  | MT-16-10** | 28.0                 | 35.0       | 16                | 500 | 300 | 200 | 50 | 200 | 120 | 32 | 23         |



\*\* With flattened section for use with BL

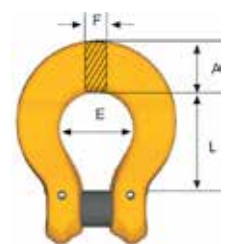
**Coupling Link G** EN 1677-1

| Art. no. | Code      | WLL tonnes* | For chain dim. | L   | B  | F  | A  | C  | Weight kgs |
|----------|-----------|-------------|----------------|-----|----|----|----|----|------------|
| Z622882  | G-6-8     | 1.12        | 6              | 45  | 15 | 7  | 8  | 17 | 0.1        |
| Z279333  | G-7/8-8   | 2.0         | 7, 8           | 56  | 18 | 9  | 11 | 22 | 0.2        |
| Z279430  | G-10-8    | 3.2         | 10             | 68  | 25 | 9  | 11 | 26 | 0.3        |
| Z279537  | G-13-8    | 5.4         | 13             | 89  | 29 | 12 | 13 | 33 | 0.7        |
| Z279634  | G-16-8    | 8.0         | 16             | 105 | 36 | 15 | 17 | 40 | 1.2        |
| Z279731  | G-18/20-8 | 12.5        | 19             | 125 | 43 | 19 | 20 | 47 | 1.9        |
| Z279838  | G-22-8    | 15.5        | 22             | 152 | 50 | 23 | 26 | 59 | 3.0        |
| Z349171  | G-26-8    | 21.6        | 26             | 161 | 58 | 26 | 28 | 61 | 5.2        |
| Z349189  | G-32-8    | 32.8        | 32             | 200 | 70 | 32 | 34 | 77 | 9.5        |



**Berglok Chain Coupler BL** EN 1677-1

| Art. no. | Code     | WLL tonnes* | For chain dim. | L  | E  | F  | A  | Weight kgs |
|----------|----------|-------------|----------------|----|----|----|----|------------|
| Z622036  | BL-6-8   | 1.12        | 6              | 27 | 20 | 9  | 14 | 0.1        |
| Z195823  | BL-7/8-8 | 2.0         | 7, 8           | 35 | 25 | 11 | 18 | 0.2        |
| Z208022  | BL-10-8  | 3.2         | 10             | 45 | 32 | 14 | 22 | 0.4        |
| Z217820  | BL-13-8  | 5.4         | 13             | 56 | 40 | 17 | 28 | 0.8        |
| Z208226  | BL-16-8  | 8.0         | 16             | 68 | 50 | 22 | 35 | 1.4        |



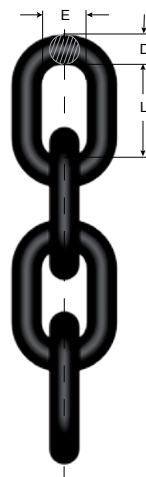
\*Safety factor 4:1

All dimensions in mm

**Chain Classic Grade 8** EN 818-2 Short link chain, KL

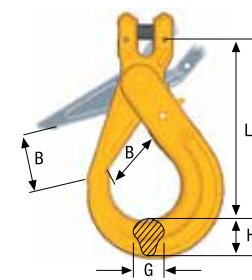
**Heat treatment** Quenched and tempered.  
**Surface treatment** Painted black (KLB)  
 Painted yellow (KLU)  
**Marking** 8E

| Art.no Box          | Code      | D nom. | L  | E   | Weight kgs/m | WLL tonnes * | Manufact. proof force kN | Breaking force kN |
|---------------------|-----------|--------|----|-----|--------------|--------------|--------------------------|-------------------|
| Z802174 - 1 x 200 m | KLB 6-8E  | 6      | 18 | 8.5 | 0.8          | 1.1          | 28.3                     | 45.2              |
| Z802175 - 1 x 200 m | KLB 7-8E  | 7      | 21 | 10  | 1.1          | 1.5          | 38.5                     | 62                |
| Z802176 - 1 x 200 m | KLB 8-8E  | 8      | 24 | 11  | 1.4          | 2.0          | 50.3                     | 80.6              |
| Z802156 - 1 x 100 m | KLB 10-8E | 10     | 30 | 14  | 2.2          | 3.2          | 78.5                     | 130               |
| Z802157 - 1 x 100 m | KLB 13-8E | 13     | 39 | 18  | 3.7          | 5.4          | 133                      | 214               |
| Z802177 - 1 x 100 m | KLB 16-8E | 16     | 48 | 22  | 5.6          | 8.0          | 201                      | 322               |
| Z801203 - 1 x 100 m | KLB 19-8E | 19     | 57 | 26  | 7.8          | 11.6         | 284                      | 457               |
| Z801228 - 1 x 50 m  | KLB 22-8E | 22     | 66 | 30  | 10.6         | 15.5         | 380                      | 610               |
| Z801231 - 1 x 50 m  | KLB 26-8E | 26     | 78 | 35  | 14.8         | 21.6         | 531                      | 850               |
| Z801232 - 1 x 25 m  | KLB 32-8E | 32     | 96 | 43  | 21.6         | 32.8         | 804                      | 1300              |



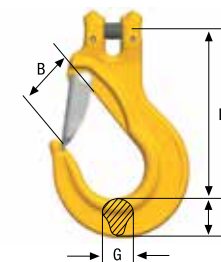
**Safety hook BKG** EN 1677-3

| Art. no. | Code      | WLL tonnes* | For chain dim. | L   | B  | G  | H  | Weight appr. kgs |
|----------|-----------|-------------|----------------|-----|----|----|----|------------------|
| Z297222  | BKG-7/8-8 | 2.0         | 7, 8           | 120 | 37 | 17 | 26 | 0.9              |
| Z295929  | BKG-10-8  | 3.2         | 10             | 143 | 45 | 21 | 30 | 1.5              |
| Z291527  | BKG-13-8  | 5.4         | 13             | 179 | 55 | 30 | 39 | 2.8              |
| Z291624  | BKG-16-8  | 8.0         | 16             | 217 | 62 | 37 | 48 | 5.1              |



**Sling hook EGKN with latch** EN 1677-2

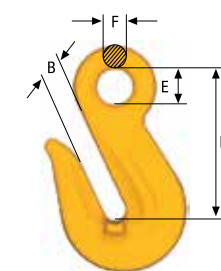
| Art. no. | Code       | WLL tonnes* | For chain dim. | L   | B  | G  | H  | Weight appr. kgs |
|----------|------------|-------------|----------------|-----|----|----|----|------------------|
| Z100744  | EGKN-7/8-8 | 2.0         | 7, 8           | 95  | 29 | 17 | 22 | 0.5              |
| Z100772  | EGKN-10-8  | 3.2         | 10             | 121 | 37 | 19 | 29 | 0.9              |
| Z100773  | EGKN-13-8  | 5.4         | 13             | 147 | 42 | 27 | 36 | 2.0              |
| Z100774  | EGKN-16-8  | 8.0         | 16             | 170 | 49 | 34 | 44 | 3.6              |



**Grab hook OG** EN 1677-1

Not for use with Berglok. No reduction of working load limit, thanks to supporting lugs on either side of hook to prevent chain link deformation.

| Art. no. | Code     | WLL tonnes* | For chain dim. | L   | B  | E  | F  | Weight appr. kgs |
|----------|----------|-------------|----------------|-----|----|----|----|------------------|
| Z100811  | OG-7/8-8 | 2.0         | 7, 8           | 65  | 10 | 16 | 10 | 0.3              |
| Z291022  | OG-10-8  | 3.2         | 10             | 85  | 12 | 20 | 12 | 0.6              |
| Z295220  | OG-13-8  | 5.4         | 13             | 104 | 15 | 25 | 16 | 1.2              |
| Z296221  | OG-16-8  | 8.0         | 16             | 130 | 19 | 30 | 19 | 2.4              |



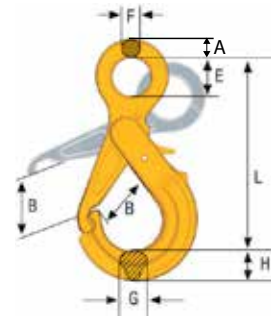
\*Safety factor 4:1

All dimensions in mm



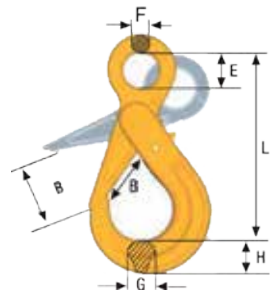
**Safety Hook OBK** with griplatch EN 1677-3

| Art. no. | Code     | WLL tonnes* | For chain dim. | A  | L   | B  | E  | F  | G  | H  | Weight kgs |
|----------|----------|-------------|----------------|----|-----|----|----|----|----|----|------------|
| Z100218  | OBK-22-8 | 15.5        | 22             | 30 | 335 | 87 | 70 | 24 | 40 | 57 | 10.2       |



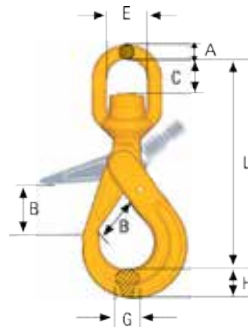
**Safety Hook BK** EN 1677-3

| Art. no. | Code    | WLL tonnes* | For chain dim. | L   | B   | E  | F  | G  | H  | Weight kgs |
|----------|---------|-------------|----------------|-----|-----|----|----|----|----|------------|
| Z101357  | BK-32-8 | 32.8        | 32             | 400 | 120 | 90 | 30 | 62 | 86 | 23.8       |



**Safety Hook BCLK** EN 1677-3

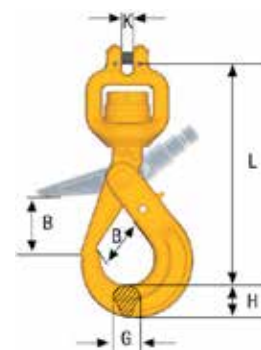
| Art. no. | Code         | WLL tonnes* | For chain dim. | L   | B   | C   | E   | A  | G  | H  | Weight kgs |
|----------|--------------|-------------|----------------|-----|-----|-----|-----|----|----|----|------------|
| Z101344  | BCLK-32-8 OS | 32.8        | 32             | 533 | 120 | 110 | 102 | 45 | 62 | 86 | 32.3       |



**Clevis Swivel Safety Hook BKH** with ball bearing

EN 1677-3

| Art. no. | Code      | WLL tonnes* | For chain dim. | L   | B  | K   | G  | H  | Weight kgs |
|----------|-----------|-------------|----------------|-----|----|-----|----|----|------------|
| Z336222  | BKH-6-8   | 1.12        | 6              | 145 | 29 | 6.8 | 15 | 21 | 0.7        |
| Z700809  | BKH-7/8-8 | 2.0         | 7 - 8          | 181 | 37 | 8.8 | 17 | 26 | 1.2        |

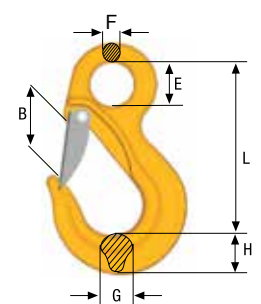


**Sling Hook EK** (without latch) and **EKN** (with latch)

| Art. no.         | Code      | WLL tonnes* | For chain dim. | L   | B   | E  | F  | G  | H  | Weight kgs |  |
|------------------|-----------|-------------|----------------|-----|-----|----|----|----|----|------------|--|
| <b>EN 1677-2</b> |           |             |                |     |     |    |    |    |    |            |  |
| Z100720          | EK-32-8   | 32.8        | 32             | 333 | 105 | 76 | 38 | 61 | 80 | 17.7       |  |
| Z100725          | EKN- 32-8 | 32.8        | 32             | 333 | 93  | 76 | 38 | 61 | 80 | 17.9       |  |

**DIN 7540 - Also available in ROV version**

|         |           |    |  |     |     |     |      |     |     |  |
|---------|-----------|----|--|-----|-----|-----|------|-----|-----|--|
| Z101382 | DK-50T-8  | 50 |  | 442 | 124 | 130 | 50.5 | 89  | 116 |  |
| Z101361 | DKN-50T-8 | 50 |  | 442 | 124 | 130 | 50.5 | 89  | 116 |  |
| Z101384 | DK-80T-8  | 80 |  | 610 | 155 | 102 | 63   | 110 | 145 |  |
| Z101363 | DKN-80T-8 | 80 |  | 610 | 155 | 102 | 63   | 110 | 145 |  |

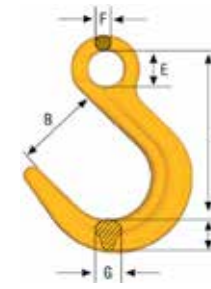


\*Safety factor 4:1

All dimensions in mm

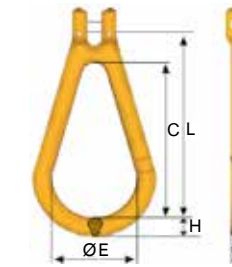
**Foundry Hook OKE** EN 1677-1

| Art. no. | Code     | WLL tonnes* | For chain dim. | L   | B   | E  | F  | G  | H  | Weight appr. kgs |
|----------|----------|-------------|----------------|-----|-----|----|----|----|----|------------------|
| Z645564  | OKE-32-8 | 32.8        | 32             | 384 | 145 | 90 | 42 | 77 | 94 | 30               |



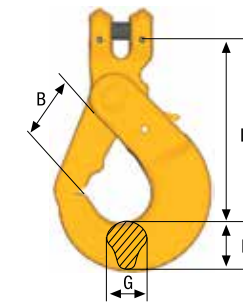
**Clevis Egglink CEL** EN 1677-1

| Art. no. | Code      | WLL tonnes* | For chain dim. | C   | E  | G  | H  | L   | Weight kgs |
|----------|-----------|-------------|----------------|-----|----|----|----|-----|------------|
| Z700968  | CEL-7/8-8 | 2.0         | 7, 8           | 80  | 40 | 14 | 15 | 100 | 0.4        |
| Z700969  | CEL-10-8  | 3.2         | 10             | 100 | 50 | 18 | 19 | 126 | 0.7        |
| Z700970  | CEL-13-8  | 5.4         | 13             | 130 | 65 | 23 | 25 | 162 | 1.5        |



**Container Hook BKGC** EN 1677-3

| Art. no. | Code      | WLL tonnes* | For chain dim. | L   | B  | G  | H  | Weight kgs |
|----------|-----------|-------------|----------------|-----|----|----|----|------------|
| Z100240  | BKGC-13-8 | 5.4         | 13             | 164 | 55 | 27 | 43 | 3.2        |
| Z100242  | BKGC-16-8 | 8.0         | 16             | 160 | 55 | 27 | 43 | 3.4        |



(Spare part: RDOBK-16 to both sizes)



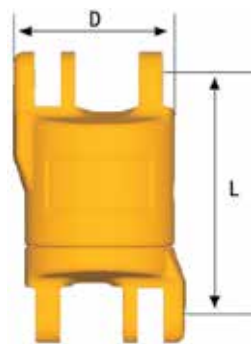
\*Safety factor 4:1

All dimensions in mm

# Roller-Bearing Swivel, SKLI/SKLU EN 1677-1

Electrically insulated, lubricated, sealed roller bearing swivel. Fully rotational even at maximum load. Tested to resist 1.000 V. Suitable for protection of overhead cranes during welding operations on suspended loads.

The Gunnebo Industries SKLI is equipped with a heavy duty roller bearing, enabling high durability and safe use also under severe load. It also has heavy duty nylon insulation inside to decrease friction when in use. The SKLI is compatible with the entire Gunnebo Industries SK-range for versatile use.



| Art. no. | Code         | WLL tonnes* | For chain dim. | L   | D   | Weight kgs |
|----------|--------------|-------------|----------------|-----|-----|------------|
| Z100316  | SKLI-7/8-8   | 2           | 7, 8           | 75  | 48  | 0.7        |
| Z100414  | SKLI-10-8    | 3.2         | 10             | 97  | 59  | 1.3        |
| Z100415  | SKLI-13-8    | 5.4         | 13             | 120 | 75  | 2.8        |
| Z100416  | SKLI-16-8    | 8           | 16             | 137 | 90  | 4.6        |
| Z100417  | SKLI-18/20-8 | 12.5        | 19             | 159 | 104 | 7.3        |
| RS16520  | SKLU-22-8*   | 15.5        | 22             | 160 | 109 | 9.2        |
| RS16530  | SKLU-26-8*   | 21.6        | 26             | 207 | 135 | 18.3       |

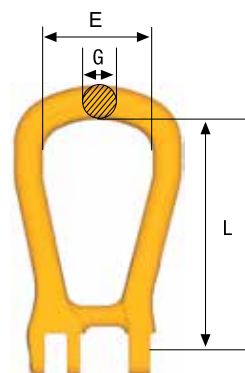
\* Uninsulated



| Art. no. | Code        | Weight kgs |
|----------|-------------|------------|
| Z700674  | SKA-6-8     | 0.01       |
| Z323624  | SKA-7/8-8   | 0.02       |
| Z318024  | SKA-10-8    | 0.04       |
| Z303822  | SKA-13-8    | 0.08       |
| Z303725  | SKA-16-8    | 0.14       |
| Z145048  | SKA-18/20-8 | 0.26       |
| Z133530  | SKA-22-8    | 0.35       |
| Z605407  | SKA-26-8    | 0.63       |

## Master Link SKG (closed) EN 1677-1

| Art. no. | Code        | WLL tonnes* | For chain dim. | L   | E   | G  | Weight kgs |
|----------|-------------|-------------|----------------|-----|-----|----|------------|
| Z419684  | SKG-7/8-8   | 2           | 7, 8           | 99  | 50  | 14 | 0.3        |
| Z419781  | SKG-10-8    | 3.2         | 10             | 127 | 66  | 18 | 0.6        |
| Z419888  | SKG-13-8    | 5.4         | 13             | 145 | 72  | 22 | 1.1        |
| Z419985  | SKG-16-8    | 8           | 16             | 175 | 82  | 25 | 1.5        |
| Z420086  | SKG-18/20-8 | 12.5        | 19             | 204 | 105 | 30 | 3.0        |

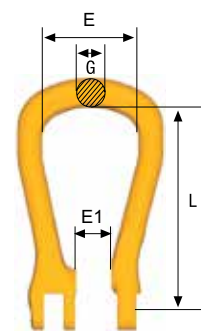


\*Safety factor 4:1

All dimensions in mm

## Master Link SKO (open) EN 1677-1

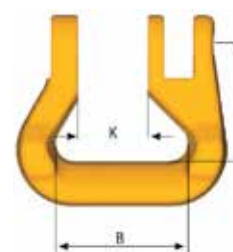
| Art. no. | Code        | WLL tonnes* | For chain dim. | L   | E   | G  | E1 | Weight kgs |
|----------|-------------|-------------|----------------|-----|-----|----|----|------------|
| Z418683  | SKO-7/8-8   | 2           | 7, 8           | 99  | 50  | 14 | 15 | 0.3        |
| Z418780  | SKO-10-8    | 3.2         | 10             | 127 | 66  | 18 | 20 | 0.6        |
| Z419383  | SKO-13-8    | 5.4         | 13             | 145 | 72  | 22 | 25 | 1          |
| Z419480  | SKO-16-8    | 8           | 16             | 175 | 82  | 25 | 30 | 1.5        |
| Z419587  | SKO-18/20-8 | 12.5        | 19             | 204 | 105 | 30 | 36 | 2.9        |



## Roundsling Coupling SKR EN 1677-1

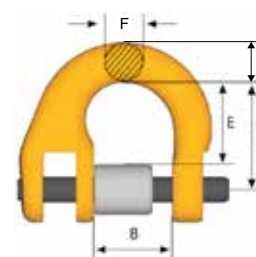
Special shape for full WLL of the roundsling

| Art. no. | Code        | WLL tonnes* | L   | B   | K  | Weight kgs |
|----------|-------------|-------------|-----|-----|----|------------|
| Z127840  | SKR-7/8-8   | 2           | 35  | 40  | 18 | 0.2        |
| Z143143  | SKR-10-8    | 3.2         | 42  | 47  | 24 | 0.4        |
| Z302538  | SKR-13-8    | 5.4         | 50  | 53  | 29 | 0.7        |
| Z143240  | SKR-16-8    | 8           | 62  | 67  | 35 | 1.3        |
| Z143347  | SKR-18/20-8 | 12.5        | 71  | 80  | 43 | 1.9        |
| Z100057  | SKR-22-8    | 15.5        | 111 | 125 | 50 | 5.3        |
| Z100055  | SKR-26-8    | 21.6        | 129 | 150 | 58 | 8.9        |



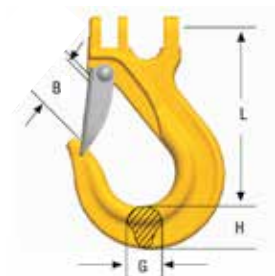
## Half-link SKT (incl. locking set) EN 1677-1

| Art. no. | Code        | WLL tonnes* | For chain dim. | L   | B  | F  | A  | E  | Weight kgs |
|----------|-------------|-------------|----------------|-----|----|----|----|----|------------|
| Z426286  | SKT-7/8-8   | 2           | 7, 8           | 28  | 18 | 9  | 11 | 22 | 0.1        |
| Z426383  | SKT-10-8    | 3.2         | 10             | 34  | 25 | 11 | 13 | 26 | 0.2        |
| Z426480  | SKT-13-8    | 5.4         | 13             | 44  | 30 | 15 | 16 | 33 | 0.4        |
| Z426587  | SKT-16-8    | 8           | 16             | 52  | 36 | 19 | 20 | 40 | 0.6        |
| Z426684  | SKT-18/20-8 | 12.5        | 19             | 63  | 43 | 22 | 23 | 48 | 1.1        |
| Z100225  | SKT-22-8    | 15.5        | 22             | 76  | 50 | 24 | 26 | 60 | 1.7        |
| Z100226  | SKT-26-8    | 21.6        | 26             | 80  | 58 | 30 | 33 | 61 | 2.6        |
| Z100227  | SKT-32-8    | 32.8        | 32             | 100 | 70 | 38 | 40 | 78 | 4.9        |



## Sling Hook ESKN/SKN with latch EN 1677-2

| Art. no. | Code         | WLL tonnes* | For chain dim. | L   | B  | G  | H  | Weight kgs |
|----------|--------------|-------------|----------------|-----|----|----|----|------------|
| Z424682  | SKN-7/8-8    | 2.0         | 7, 8           | 90  | 27 | 18 | 21 | 0.4        |
| Z424789  | SKN-10-8     | 3.2         | 10             | 115 | 34 | 23 | 29 | 0.8        |
| Z101214  | ESKN-13-8    | 5.4         | 13             | 145 | 42 | 28 | 36 | 1.8        |
| Z100786  | ESKN-16-8    | 8.0         | 16             | 178 | 54 | 38 | 43 | 3.4        |
| Z100781  | ESKN-18/20-8 | 12.5        | 19             | 197 | 59 | 49 | 51 | 5.1        |



\*Safety factor 4:1

All dimensions in mm



How do you transform your excavator into a crane?

# Universal Weld-On Hook, UKN

For excavators, construction machinery, lifting beams etc. Specified by leading excavator manufacturers.

## Welding Instructions for UKN

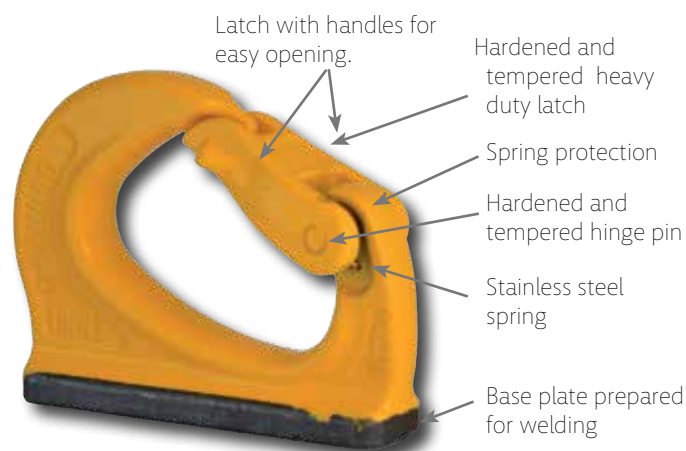
**WARNING!** WELDING OPERATION SHOULD BE CARRIED OUT BY A TRAINED WELDER.

### ELECTRODES

Electrodes or wire must be for use with non-alloy or low-alloy steel. Electrodes must not be wet. Do not use rusty welding wire.

### Following types are recommended:

ISO 2560, DIN EN 499, BS EN 499, AWS A 5.1 E 7018 or equal.

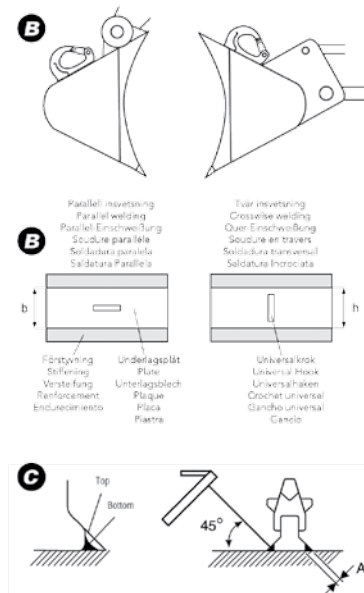


### B. POSITIONING

These are universal hooks and can be welded on to different supporting materials (e.g. girder). If the hook is welded on to a bucket it should be placed so that:

1. it will withstand all strains caused by different positions of the bucket.
2. any damage to the coupling element which might be caused by the other parts of the excavator is avoided.
3. the user will not be injured (pinched or cut).
4. any unintentional unhooking of the coupling element will be made impossible.
5. the coupling element can be easily hooked and unhooked.
6. it doesn't hamper excavation and lifting.

The hook should be placed in the middle at the upper part of the bucket. The position should be protected, but also easy to reach. Figure shows two different positions. Before use a competent person shall certify that the hook may be taken into use. Always take into consideration the tensile strength and thickness of the supporting material. Proof load testing may be required



### C. WELDING

Before welding, the surfaces must be cleaned thoroughly from rust, paint or similar.

**NOTE!** At temperatures below 0°C the welding surfaces should be preheated.

Positioning of the hook should be done by spot welding in each corner. Next, the bottom joint is to be welded and must be carried out continuously (well filled all around). Welding torch or electrode should be held at 45° (see figure), to obtain required penetration. When the top joint is to be welded, a larger electrode maybe chosen. Minimum value of throat thickness, A, (see table) must be achieved. Cracks or pores are not permitted.

**NOTE!** The welded joint must NOT be cooled by water. Only non-forced air cooling is allowed. The pin (axle) should be lubricated until the hook has reached ambient temperature

In service temperature: -40 °C to +200 °C without reduction of the WLL

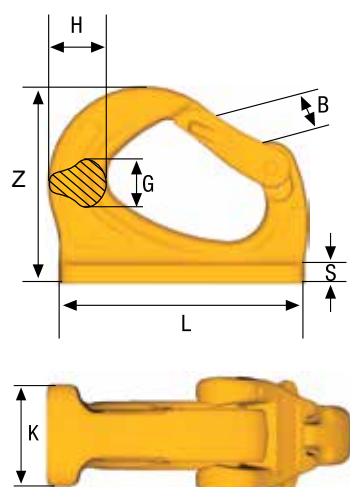
Can also be provided unpainted

| Art. no. | Code      | WLL tonnes** | B  | G  | H  | K  | L    | S  | Z   | Weight kgs |
|----------|-----------|--------------|----|----|----|----|------|----|-----|------------|
| Z1002560 | UKN-0,75* | 0.75         | 20 | 13 | 20 | 19 | 81.5 | 5  | 56  | 0.2        |
| Z6511810 | UKN-1*    | 1            | 27 | 17 | 25 | 25 | 95   | 6  | 72  | 0.6        |
| Z7009060 | UKN-2*    | 2            | 33 | 20 | 30 | 30 | 114  | 8  | 86  | 0.9        |
| Z6455730 | UKN-3     | 3            | 30 | 23 | 32 | 35 | 132  | 10 | 105 | 1.3        |
| Z6521160 | UKN-4     | 4            | 30 | 29 | 38 | 42 | 140  | 11 | 114 | 2.0        |
| Z6455800 | UKN-5     | 5            | 34 | 30 | 47 | 45 | 165  | 12 | 131 | 3.2        |
| Z6515390 | UKN-8     | 8            | 34 | 40 | 51 | 50 | 172  | 13 | 133 | 3.6        |
| Z6456030 | UKN-10    | 10           | 47 | 43 | 58 | 55 | 220  | 14 | 170 | 8.2        |
| Z1007850 | UKN-15    | 15           | 55 | 50 | 67 | 60 | 240  | 15 | 188 | 9.8        |

\* Welding plate slightly curved

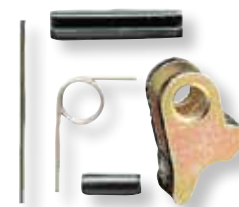
\*\* Safety factor 5:1

If welding on to an excavator or its accessories we recommend that when necessary the working load limit is reduced, to meet legislative requirements. Please contact your distributor for further information.



All dimensions in mm

## Spare Part RDBK (with assembly kit)



Set for BK/BKG Safety hooks consists of trigger, stainless steel spring, retaining pin and assembly kit.

### Recessed trigger

| Art. no. | Code       | Weight kgs |
|----------|------------|------------|
| Z100282  | RDBK-6     | 0.02       |
| Z100283  | RDBK-8     | 0.03       |
| Z100284  | RDBK-10    | 0.03       |
| Z100285  | RDBK-13    | 0.05       |
| Z100286  | RDBK-16    | 0.10       |
| Z100297  | RDBK-18/20 | 0.21       |
| Z100287  | RDBK-22    | 0.20       |
| Z100280  | RDBK-26    | 0.50       |
| Z100294  | RDBK-32-8  | 0.40       |

### Standard trigger

| Art. no. | Code       | Weight kgs |
|----------|------------|------------|
| Z1002820 | RDBK-6     | 0.01       |
| Z1002830 | RDBK-8     | 0.03       |
| Z1002840 | RDBK-10    | 0.03       |
| Z1002850 | RDBK-13    | 0.05       |
| Z1002860 | RDBK-16    | 0.12       |
| Z100292  | RDBK-28/32 | 0.45       |

## Spare Part RDOBK / GBK (with assembly kit)



Set for OBK/GBK Safety hooks consists of trigger, stainless steel spring, retaining pin and assembly kit.

| Art. no. | Code        | Weight kgs |
|----------|-------------|------------|
| Z100281  | RDOBK-6     | 0.01       |
| Z100288  | RDOBK-7/8   | 0.02       |
| Z100289  | RDOBK-10    | 0.03       |
| Z100290  | RDOBK-13    | 0.05       |
| Z100291  | RDOBK-16    | 0.08       |
| Z100297  | RDOBK-18/20 | 0.21       |
| Z100323  | RDOBK-22-8  | 0.35       |

## Spare Part RDBKD (with assembly kit)



| Art. no. | Code                     | Weight kgs |
|----------|--------------------------|------------|
| Z101157  | RDBKD-13 double latch    |            |
| Z101158  | RDBKD-16 double latch    |            |
| Z101159  | RDBKD-18/20 double latch |            |

## Spare Part GKN / OKN



| Art. no. | Code          | Weight kgs |
|----------|---------------|------------|
| Z622175  | GKN/OKN-7/8-8 | 0.05       |
| Z622183  | GKN/OKN-10-8  | 0.09       |
| Z622206  | GKN/OKN-13-8  | 0.13       |
| Z622214  | GKN-16-8      | 0.22       |

Set consists of latch, stainless steel spring and rivet.

## Spare Part LKN / LKNK / EKN / OKN / EGKN / RH / ESKN

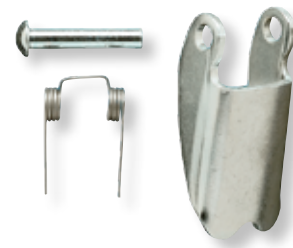
| Art.no. | Code                   | Weight kgs |
|---------|------------------------|------------|
| Z100445 | RDEKN- 6 / OKN / RH 1  | 0.03       |
| Z100447 | RDEKN- 7/8 /LKN / RH 2 | 0.05       |
| Z100450 | RDEKN-10 / LKN / RH 3  | 0.06       |
| Z100449 | RDEKN-13 / LKN / RH 5  | 0.13       |
| Z100217 | RDEKN-16 / LKN         | 0.20       |
| Z100453 | RDEKN-18/20            | 0.26       |
| Z100452 | RDEKN-22               | 0.42       |
| Z100742 | RDEKN-26               | 0.53       |
| Z100743 | RDEKN-32               | 0.60       |



Set consists of latch, stainless steel spring and rivet.

## Spare Part Set SKN, OKN and LKN (old version)

| Art. no. | Code            | Weight kgs |
|----------|-----------------|------------|
| Z420581  | SKN/LKN-7/8-8   | 0.05       |
| Z420688  | SKN/LKN-10-8    | 0.10       |
| Z420785  | SKN/LKN-13-8    | 0.14       |
| Z420989  | SKN/OKN-16-8    | 0.22       |
| Z421087  | SKN/OKN-18/20-8 | 0.27       |
| Z700698  | OKN-22-8        | 0.48       |



Set consists of latch, stainless steel spring and rivet.

## Spare Part UKN

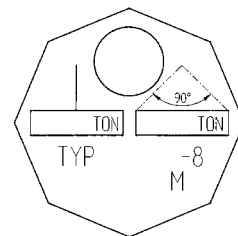
| Art. no. | Code       | Weight kgs |
|----------|------------|------------|
| Z100258  | RDUKN-0.75 | 0.06       |
| Z700264  | RDUKN-1    | 0.12       |
| Z700958  | RDUKN-2    | 0.20       |
| Z700266  | RDUKN-3/4  | 0.20       |
| Z700268  | RDUKN-5/8  | 0.36       |
| Z700269  | RDUKN-10   | 0.88       |
| Z700984  | RDUKN-15   | 1.20       |



Spare part set RDUKN (msp) consists of forged latch, pin, stainless steel spring and retaining pin.

## Id-tag Stainless

| Art.no. | Code   |
|---------|--------|
| Z100004 | Id-tag |



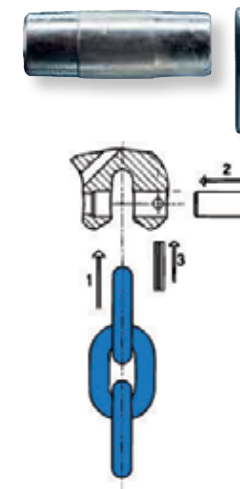
## Sling Id-tag Stainless steel

| Art. no. | Code                                 |
|----------|--------------------------------------|
| B14841   | Flexitag 6 mm with ferrule and wire  |
| B14842   | Flexitag 8 mm with ferrule and wire  |
| B14843   | Flexitag 10 mm with ferrule and wire |
| B14844   | Flexitag 13 mm with ferrule and wire |
| B14845   | Flexitag 16 mm with ferrule and wire |
| Z100971  | Flexitag 6 mm                        |
| Z100972  | Flexitag 8 mm                        |
| Z100973  | Flexitag 10 mm                       |
| Z100974  | Flexitag 13 mm                       |
| Z100975  | Flexitag 16 mm                       |
| Z101077  | Flexitag 20 mm                       |
| Z100899  | Flexitag Neutral                     |



## Load Pin Set CLS

| Art. no. | Code   | Weight kgs/ea |
|----------|--------|---------------|
| B14930   | CLS- 6 | 0.01          |
| B14931   | CLS- 8 | 0.02          |
| B14932   | CLS-10 | 0.04          |
| B14933   | CLS-13 | 0.09          |
| B14934   | CLS-16 | 0.16          |
| B14935   | CLS-20 | 0.26          |



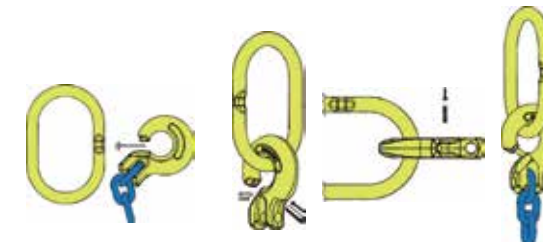
Clevis connection set (CLS) consists of one load pin and one spring retaining pin.

## Spare Part CS

| Art. no. | Code                | Weight kgs/ea |
|----------|---------------------|---------------|
| B14920   | CS- 6-10            | 0.01          |
| B14921   | CS- 8-10 / RH-1& -2 | 0.01          |
| B14922   | CS-10-10 / RH-3     | 0.01          |
| B14923   | CS-13-10            | 0.03          |
| B14924   | CS-16-10 / RH-5     | 0.05          |

The C-connection set CS, for CG, CGD, CL, CLD and RH hook, consists of one blocking pin and one spring retaining pin, for locking.

## Assembly: C-coupling - C-grab/C-lok with MF



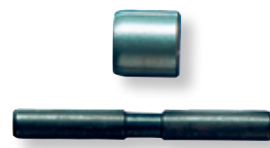
## Close/Open Locking Set FlexiLeg Quick Pin

| Art. no. | Code     | Weight kgs |
|----------|----------|------------|
| Z101010  | QP-6-10  | 0.01       |
| Z101011  | QP-8-10  | 0.01       |
| Z101012  | QP-10-10 | 0.01       |
| Z101013  | QP-13-10 | 0.03       |
| Z101014  | QP-16-10 | 0.06       |



## Spare Part Set SKA

| Art. no. | Code        | Weight kgs | Art. no. | Code        | Weight kgs |
|----------|-------------|------------|----------|-------------|------------|
| Z100989  | SKA- 6-10   | 0.01       | Z700674  | SKA-6-8     | 0.01       |
| Z100933  | SKA- 7/8-10 | 0.02       | Z323624  | SKA-7/8-8   | 0.02       |
| Z100934  | SKA-10-10   | 0.04       | Z318024  | SKA-10-8    | 0.04       |
| Z100990  | SKA-13-10   | 0.08       | Z303822  | SKA-13-8    | 0.08       |
| Z100991  | SKA-16-10   | 0.14       | Z303725  | SKA-16-8    | 0.14       |
| Z101176  | SKA-20-10   | 0.26       | Z145048  | SKA-18/20-8 | 0.26       |
| Z650555  | SKA-22-10   | 0.35       | Z133530  | SKA-22-8    | 0.35       |
| Z650556  | SKA-26-10   | 0.63       | Z605407  | SKA-26-8    | 0.63       |
|          |             |            | Z650554  | SKA-32-8    | 1.05       |



SKA locking set for G-link, consists of a load pin and locking collar.

## Spare Part Set Berglok BLA

| Art. no. | Code      | Weight kgs |
|----------|-----------|------------|
| Z275649  | BLA-6-8   | 0.01       |
| Z275347  | BLA-7/8-8 | 0.02       |
| Z275444  | BLA-10-8  | 0.04       |
| Z275648  | BLA-13-8  | 0.08       |
| Z276047  | BLA-16-8  | 0.15       |
| Z276241  | BLA-19-8  | 0.26       |

Set for Berglok and Clevis type connections. Consists of one load pin and two retaining pins.



## Locking Set Midgrab MIG

| Art. no. | Code | Weight kgs |
|----------|------|------------|
| B14904   | C-8  | 0.02       |
| B14905   | L-8  | 0.02       |
| B14914   | C-10 | 0.02       |
| B14915   | L-10 | 0.02       |
| B14916   | C-13 | 0.08       |
| B14917   | L-13 | 0.05       |



L - Permanent locking function



C - Close/open function

## Working Load Limits

### Grade 10 GrabiQ (tonnes)

| Chain dim. |      | 2-leg                           |                                    | 3- & 4-leg                      |                                    | Choke hitch                     |                                    |
|------------|------|---------------------------------|------------------------------------|---------------------------------|------------------------------------|---------------------------------|------------------------------------|
|            |      | $\beta$ 0-45°<br>$\alpha$ 0-90° | $\beta$ 45-60°<br>$\alpha$ 90-120° | $\beta$ 0-45°<br>$\alpha$ 0-90° | $\beta$ 45-60°<br>$\alpha$ 90-120° | $\beta$ 0-45°<br>$\alpha$ 0-90° | $\beta$ 45-60°<br>$\alpha$ 90-120° |
| 6          | 1.5  | 2.1                             | 1.5                                | 3.15                            | 2.2                                | 1.6                             | 1.2                                |
| 7          | 2.0  | 2.8                             | 2.0                                | 4.2                             | 3.0                                | 2.2                             | 1.6                                |
| 8          | 2.5  | 3.5                             | 2.5                                | 5.2                             | 3.7                                | 2.7                             | 2                                  |
| 10         | 4.0  | 5.6                             | 4                                  | 8.4                             | 6                                  | 4.4                             | 3.2                                |
| 13         | 6.7  | 9.5                             | 6.7                                | 14.0                            | 10                                 | 7.4                             | 5.3                                |
| 16         | 10   | 14                              | 10                                 | 21.0                            | 15                                 | 11                              | 8                                  |
| 20         | 16   | 22.4                            | 16                                 | 33.6                            | 24                                 | 17.6                            | 12.8                               |
| 22         | 20.0 | 28.0                            | 20.0                               | 42.0                            | 30.0                               | 22.0                            | 16.0                               |
| 26         | 27.0 | 38.2                            | 27.0                               | 57.3                            | 40.5                               | 29.7                            | 21.6                               |

Safety factor 4:1 Working load limits are based upon equally loaded and disposed sling legs.

### Grade 8 Classic (tonnes)

EN 818-4:1996

| Chain dim. mm | 1-leg | 2-leg                           |                                    | 3-leg & 4-leg                   |                                    | Choked endless sling |
|---------------|-------|---------------------------------|------------------------------------|---------------------------------|------------------------------------|----------------------|
|               |       | $\beta$ 0-45°<br>$\alpha$ 0-90° | $\beta$ 45-60°<br>$\alpha$ 90-120° | $\beta$ 0-45°<br>$\alpha$ 0-90° | $\beta$ 45-60°<br>$\alpha$ 90-120° |                      |
| 6             | 1.1   | 1.6                             | 1.1                                | 2.36                            | 1.7                                | 1.8                  |
| 7             | 1.50  | 2.12                            | 1.5                                | 3.15                            | 2.24                               | 2.5                  |
| 8             | 2.0   | 2.8                             | 2.0                                | 4.25                            | 3.0                                | 3.15                 |
| 10            | 3.15  | 4.25                            | 3.15                               | 6.7                             | 4.75                               | 5.0                  |
| 13            | 5.3   | 7.5                             | 5.3                                | 11.2                            | 8.0                                | 8.5                  |
| 16            | 8.0   | 11.2                            | 8.0                                | 17.0                            | 11.8                               | 12.5                 |
| 19            | 11.2  | 16.0                            | 11.2                               | 23.6                            | 17.0                               | 18.0                 |
| 22            | 15.0  | 21.2                            | 15.0                               | 31.5                            | 22.4                               | 23.6                 |
| 26            | 21.2  | 30.0                            | 21.2                               | 45.0                            | 31.5                               | 33.5                 |
| 32            | 31.5  | 45.0                            | 31.5                               | 67.0                            | 47.5                               | 50.0                 |

Safety factor 4:1 Working load limits are based upon equally loaded and disposed sling legs.

### Rules for Correct WLL

Where choke hitch is employed, the WLL of the chain sling should be reduced by 20 % (unless the LK choker hook is used).

### Asymmetrical Loading Conditions

For unequally loaded chain slings, the following approach to permissible loads is recommended:

- A two-legged system is treated as a single-legged system.
- A three- or four-legged system is treated as a two-legged system.

**Note! Different standards apply for Australia,**



# GrabIQ™

## The Flexible and Cost Efficient Chain Sling System.

### GrabIQ stands for:

- "Grab" - Built in shortening function allows the user to instantly adjust the chain sling.
- IQ - Intelligent design gives more efficient lifts which making the user more successful.
- IO - Grade 10 material gives 25% added strength as well as lighter slings.
- i - Innovation has been and still is one of our driving forces. Many of our products are unique on the market and are protected by patents.
- Q - Quality. No product leaves our factories without being proof loaded and visually inspected, so that we can guarantee top quality to all customers



### GrabIQ offers:

#### Cost Efficiency

GrabIQ has been designed to integrate multiple functions in each component. This means fewer components in each sling, but with the same and even better function than the old system. A good example of this is our FlexiLeg system, where one master link combined with one 1-leg sling and two 2-leg sling units, completely replaces four master links and ten legs of chain sling. Read more about FlexiLeg on page 2:6.

#### Flexibility in Field

We understand how fast the conditions for a lift can change and we also recognize that time is money in lifting operations - big and small. With the GrabIQ system we have included functions that would otherwise demand additional products or a complete change of chain sling. The user gets a quicker and more ergonomic lifting operation each time when using the GrabIQ system.

## Reduce the Cost - Increase the Efficiency

The GrabIQ system makes your lift quicker, safer and easier.

The all-inclusive chain sling system for coupling, shortening and lifting in grade 10 is designed to improve your lifting actions and make it as quick and easy as possible. Some of the top features are:

- Less components - cost efficient
- Built in shortening function
- Light weight for better ergonomics

### 4-leg sling with shortening function



Used to be 15 components



### 2-leg sling with shortening function

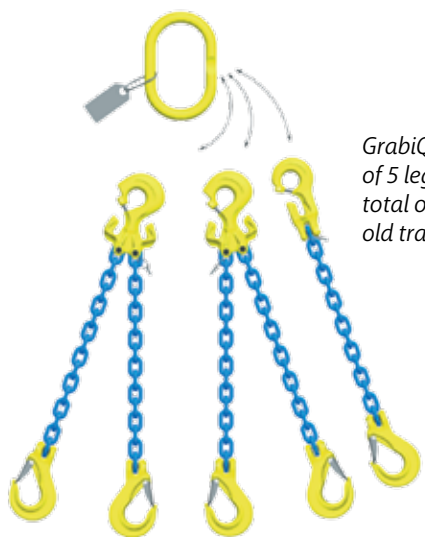


Used to be 7 components



## Less is More with FlexiLeg™

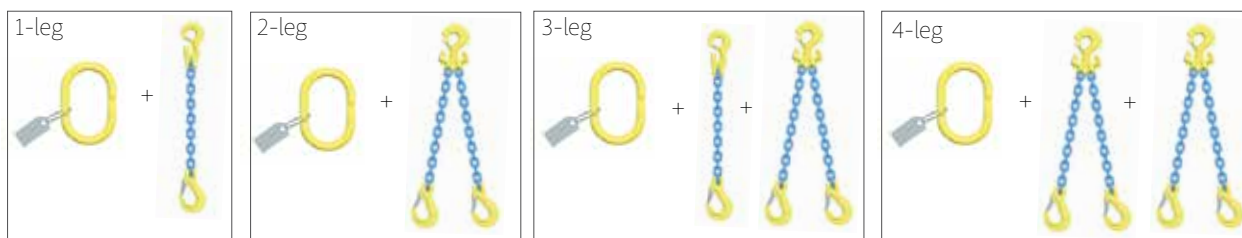
FlexiLeg is a solution that allows you to have an instant leg change. One single master link and a combination of five legs replace four complete slings, a total of ten legs, with the traditional system. By using the unique features of the GrabiQ range, Gunnebo Industries has increased the flexibility even further.



GrabiQ FlexiLeg – a total of 5 legs replaces the total of 10 legs with the old traditional system.



Old system - 10 legs in 4 separate chain slings.



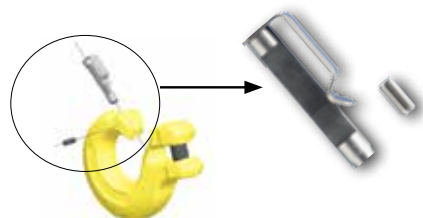
### Why do you want instant leg-change?

- It will enable the user to change slings, leg by leg, which will make it lighter and easier to work with.
- Sling legs that are not being used can easily be removed, thereby increasing safety at the work site.
- The quantity of sling material is greatly reduced, providing cost savings.
- The chain sling can be rebuilt on site, thus increasing efficiency.

| Art. no. | Code                      | WLL in tonnes* |       |            | Art. no. | Code                       | WLL in tonnes* |       |            |
|----------|---------------------------|----------------|-------|------------|----------|----------------------------|----------------|-------|------------|
|          |                           | 1-leg          | 2-leg | 3- & 4-leg |          |                            | 1-leg          | 2-leg | 3- & 4-leg |
| Z101050  | FlexiLeg GBK 6 mm L= 2 m  | 1.5            | 2.1   | 3.15       | Z101055  | FlexiLeg EGKN 10 mm L= 2 m | 4.0            | 5.6   | 8.4        |
| Z101051  | FlexiLeg EGKN 6 mm L= 2 m | 1.5            | 2.1   | 3.15       | Z101056  | FlexiLeg GBK 13 mm L= 2 m  | 6.7            | 9.5   | 14         |
| Z101052  | FlexiLeg GBK 8 mm L= 2 m  | 2.5            | 3.5   | 5.2        | Z101057  | FlexiLeg EGKN 13 mm L= 2 m | 6.7            | 9.5   | 14         |
| Z101053  | FlexiLeg EGKN 8 mm L= 2 m | 2.5            | 3.5   | 5.2        | Z101058  | FlexiLeg GBK 16 mm L= 2 m  | 10             | 14    | 21         |
| Z101054  | FlexiLeg GBK 10 mm L= 2 m | 4.0            | 5.6   | 8.4        | Z101059  | FlexiLeg EGKN 16 mm L= 2 m | 10             | 14    | 21         |

Safety factor 4:1  
\* For different lifting angles - see WLL table page 2:8.

### Related products



#### QuickPin - For safe exchange of sling legs

- Fits all C-components! (CL, CLD, CG, CGD)
- Has instant close/open function, no tools needed!
- Easy to retro-fit!
- Made of stainless steel for long product life span.



#### FlexiTag - For every GrabiQ sling

- Specially designed for FlexiLeg
- Fits all other GrabiQ slings
- WLL and chain size pre-stamped for 1 - 4 legs
- Leg angle 45/60 degree shown in contour
- Made of stainless steel for use in all weather conditions.

## Chain Sling Solutions

### 1-leg Chain Slings



Type: Master link MG, Chain KLA, Safety Hook GBK

| Dim. mm | WLL t* | Total Component length mm |
|---------|--------|---------------------------|
| 6       | 1.5    | 171                       |
| 8       | 2.5    | 296                       |
| 10      | 4.0    | 361                       |
| 13      | 6.7    | 453                       |
| 16      | 10.0   | 527                       |



Type: Master link MG, Chain KLA, Hook with latch EGKN

| Dim. mm | WLL t* | Total Component length mm |
|---------|--------|---------------------------|
| 6       | 1.5    | 231                       |
| 8       | 2.5    | 261                       |
| 10      | 4.0    | 331                       |
| 13      | 6.7    | 408                       |
| 16      | 10     | 481                       |



Type: Master link MF, C-grab CG, Chain KLA, Safety Hook BKG

| Dim. mm | WLL t* | Total Component length mm |
|---------|--------|---------------------------|
| 6       | 1.5    | 200                       |
| 8       | 2.5    | 346                       |
| 10      | 4.0    | 424                       |
| 13      | 6.7    | 504                       |
| 16      | 10.0   | 621                       |

### 2-leg Chain Sling



Type: Master link MF, C-grab CG, Chain KLA, Hook with latch EGKN

| Dim. mm | WLL t* | Total Component length mm |
|---------|--------|---------------------------|
| 6       | 1.5    | 286                       |
| 8       | 2.5    | 342                       |
| 10      | 4.0    | 415                       |
| 13      | 6.7    | 507                       |
| 16      | 10.0   | 624                       |



Type: Master link MGD, Chain KLA, Safety Hook GBK

| Dim. mm | WLL tonnes*     |                    | Component length mm |
|---------|-----------------|--------------------|---------------------|
|         | β 0-45° α 0-90° | β 45-60° α 90-120° |                     |
| 6       | 2.1             | 1.5                | 235                 |
| 8       | 3.5             | 2.5                | 296                 |
| 10      | 5.6             | 4.0                | 361                 |
| 13      | 9.5             | 6.7                | 453                 |
| 16      | 14.0            | 10.0               | 527                 |



Type: Master link MGD, Chain KLA, Latch Hook EGKN

| Dim. mm | WLL tonnes*     |                    | Component length mm |
|---------|-----------------|--------------------|---------------------|
|         | β 0-45° α 0-90° | β 45-60° α 90-120° |                     |
| 6       | 2.1             | 1.5                | 230                 |
| 8       | 3.5             | 2.5                | 261                 |
| 10      | 5.6             | 4.0                | 331                 |
| 13      | 9.5             | 6.7                | 408                 |
| 16      | 14.0            | 10.0               | 481                 |



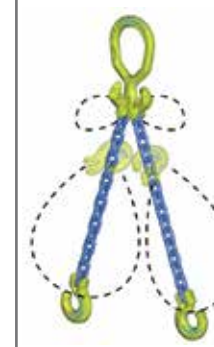
Type: Master link MF, C-grab Duo CGD, Chain KLA, Safety Hook GBK

| Dim. mm | WLL t*          |                    | Components total length mm |
|---------|-----------------|--------------------|----------------------------|
|         | β 0-45° α 0-90° | β 45-60° α 90-120° |                            |
| 6       | 2.1             | 1.5                | 291                        |
| 8       | 3.5             | 2.5                | 366                        |
| 10      | 5.6             | 4.0                | 444                        |
| 13      | 9.5             | 6.7                | 534                        |
| 16      | 14.0            | 10.0               | 671                        |



Type: Master link MF, C-grab Duo CGD, Chain KLA, Latch Hook EGKN

| Dim. mm | WLL t*          |                    | Total Component length |
|---------|-----------------|--------------------|------------------------|
|         | β 0-45° α 0-90° | β 45-60° α 90-120° |                        |
| 6       | 2.1             | 1.5                | 286                    |
| 8       | 3.5             | 2.5                | 342                    |
| 10      | 5.6             | 4.0                | 415                    |
| 13      | 9.5             | 6.7                | 507                    |
| 16      | 14.0            | 10.0               | 625                    |



Type: Master link MGD, Chain KLA, C-lok CL

| Dim. mm | WLL t*          |                    | WLL choked t*   |                    | Component total length mm |
|---------|-----------------|--------------------|-----------------|--------------------|---------------------------|
|         | β 0-45° α 0-90° | β 45-60° α 90-120° | β 0-45° α 0-90° | β 45-60° α 90-120° |                           |
| 6       | 2.1             | 1.5                | 1.6             | 1.2                | 187                       |
| 8       | 3.5             | 2.5                | 2.7             | 2.0                | 230                       |
| 10      | 5.6             | 4                  | 4.4             | 3.2                | 285                       |
| 13      | 9.5             | 6.7                | 7.4             | 5.4                | 359                       |
| 16      | 14.0            | 10.0               | 11.0            | 8.0                | 429                       |

\*Safety factor 4:1



### 3-leg Chain Sling

Type: Master link MF, C-grab CG, C-grab Duo CGD, Chain KLA, Safety Hook GBK



| Dim. mm | WLL t*                          |                                    | Total component length mm |
|---------|---------------------------------|------------------------------------|---------------------------|
|         | $\beta$ 0-45°<br>$\alpha$ 0-90° | $\beta$ 45-60°<br>$\alpha$ 90-120° |                           |
| 6       | 3.1                             | 2.2                                | 311                       |
| 8       | 5.2                             | 3.7                                | 392                       |
| 10      | 8.4                             | 6.0                                | 474                       |
| 13      | 14.0                            | 10.0                               | 604                       |
| 16      | 21.0                            | 15.0                               | 680                       |

Type: Master link MF, C-grab CG, C-grab Duo CGD, Chain KLA, Latch Hook EGKN



| Dim. mm | WLL t*                          |                                    | Total Component length mm |
|---------|---------------------------------|------------------------------------|---------------------------|
|         | $\beta$ 0-45°<br>$\alpha$ 0-90° | $\beta$ 45-60°<br>$\alpha$ 90-120° |                           |
| 6       | 3.1                             | 2.2                                | 306                       |
| 8       | 5.2                             | 3.7                                | 357                       |
| 10      | 8.4                             | 6.0                                | 444                       |
| 13      | 14.0                            | 10.0                               | 559                       |
| 16      | 21.0                            | 15.0                               | 634                       |

### 4-leg Chain Sling

Type: Master link MF, C-grab Duo CGD, Chain KLA, Safety Hook GBK



| Dim. mm | WLL t*                          |                                    | Total Component length mm |
|---------|---------------------------------|------------------------------------|---------------------------|
|         | $\beta$ 0-45°<br>$\alpha$ 0-90° | $\beta$ 45-60°<br>$\alpha$ 90-120° |                           |
| 6       | 3.1                             | 2.2                                | 311                       |
| 8       | 5.2                             | 3.7                                | 392                       |
| 10      | 8.4                             | 6.0                                | 474                       |
| 13      | 14.0                            | 10.0                               | 604                       |
| 16      | 21.0                            | 15.0                               | 680                       |

Type: Master link MF, C-grab Duo CGD, Chain KLA, Latch Hook EGKN



| Dim. mm | WLL t*                          |                                    | Total Component length mm |
|---------|---------------------------------|------------------------------------|---------------------------|
|         | $\beta$ 0-45°<br>$\alpha$ 0-90° | $\beta$ 45-60°<br>$\alpha$ 90-120° |                           |
| 6       | 3.1                             | 2.2                                | 306                       |
| 8       | 5.2                             | 3.7                                | 357                       |
| 10      | 8.4                             | 6.0                                | 444                       |
| 13      | 14.0                            | 10.0                               | 559                       |
| 16      | 21.0                            | 15.0                               | 634                       |

### WLL in tonnes, Grade 10 GrabiQ

| Chain dim. | 1-leg | 2-leg                           |                                    | 3- & 4-leg                      |                                    | Choke hitch                     |                                    |
|------------|-------|---------------------------------|------------------------------------|---------------------------------|------------------------------------|---------------------------------|------------------------------------|
|            |       | $\beta$ 0-45°<br>$\alpha$ 0-90° | $\beta$ 45-60°<br>$\alpha$ 90-120° | $\beta$ 0-45°<br>$\alpha$ 0-90° | $\beta$ 45-60°<br>$\alpha$ 90-120° | $\beta$ 0-45°<br>$\alpha$ 0-90° | $\beta$ 45-60°<br>$\alpha$ 90-120° |
| 6          | 1.5   | 2.1                             | 1.5                                | 3.15                            | 2.24                               | 1.6                             | 1.2                                |
| 7          | 2.0   | 1.8                             | 2.0                                | 4.2                             | 3.0                                | 2.2                             | 1.6                                |
| 8          | 2.5   | 3.5                             | 2.5                                | 5.2                             | 3.7                                | 2.7                             | 2.0                                |
| 10         | 4.0   | 5.6                             | 4.0                                | 8.4                             | 6.0                                | 4.4                             | 3.2                                |
| 13         | 6.7   | 9.5                             | 6.7                                | 14.0                            | 10.0                               | 7.4                             | 5.3                                |
| 16         | 10.0  | 14.0                            | 10.0                               | 21.0                            | 15.0                               | 11.0                            | 8.0                                |
| 20         | 16.0  | 22.4                            | 16.0                               | 33.6                            | 24.0                               | 17.6                            | 12.8                               |
| 22         | 20.0  | 28.0                            | 20.0                               | 42.0                            | 30.0                               | 22.0                            | 16.0                               |
| 26         | 27.0  | 38.2                            | 27.0                               | 57.3                            | 40.5                               | 29.7                            | 21.6                               |

Safety factor 4:1. Working load limits are based upon equally loaded and disposed sling legs.

### Midgrab Chain Shortener, MIG

#### Product Features

- Instant mounting and positioning on any part of the chain.
- Shortening in either chain direction; up-down.
- Designed to prevent inadvertent chain disengagement.
- Can be set idle on the chain leg when shortening is not required.
- LC version offers secure mounting with locking set on any desired part of the chain with one chain direction open for shortening.
- CC version offers close-open function in both chain directions for safe retention of the chain.



Locking Devices for Midgrab MIG Note! The MIG should be used with at least one locking device.

#### L - fixed locking set

For fixed mounting

Code:  
L-8: B14905  
L-10: B14915  
L-13: B14917



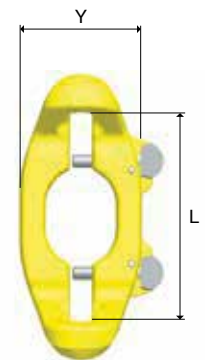
#### C - close/open locking set

Spring operated locking device. Can be placed either in open or closed position.

Code:  
C-8: B14904  
C-10: B14914  
C-13: B14916



#### Product Code Guide - Locking options



#### MIG with C pins

| Art No. | Code         | WLL tonnes* | L   | X  | Y  | Weight kgs |
|---------|--------------|-------------|-----|----|----|------------|
| B14303  | MIG CC-8-10  | 2.5         | 95  | 50 | 60 | 0.6        |
| B14313  | MIG CC-10-10 | 4.0         | 125 | 70 | 77 | 1.1        |
| B14323  | MIG CC-13-10 | 6.7         | 150 | 90 | 80 | 2.6        |

#### MIG without C pins

| Art No. | Code      | WLL tonnes* | L   | X  | Y  | Weight kgs |
|---------|-----------|-------------|-----|----|----|------------|
| B14300  | MIG-8-10  | 2.5         | 95  | 50 | 60 | 0.7        |
| B14310  | MIG-10-10 | 4.0         | 125 | 70 | 77 | 1.0        |
| B14320  | MIG-13-10 | 6.7         | 150 | 90 | 80 | 2.5        |

\*Safety factor 4:1

All dimensions in mm





---

Chain

### Short Link KLA, GrabiQ Grade 10 (200)

**Heat treatment**

Quenched and tempered.  
Note! For chain grade 10 (200) the maximum in-service temperature is 200 °C.

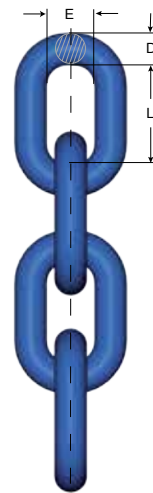
**Surface treatment**

Painted blue

**Marking**

10G

| Art. no. Box        | Code            | WLL tonnes | D nom. mm | L » mm | E » mm | Weight kgs/m | MPF kN | Breaking force kN |
|---------------------|-----------------|------------|-----------|--------|--------|--------------|--------|-------------------|
| Z802300 - 1 x 200 m | KLA 6-10 (200)  | 1.5        | 6         | 18     | 8      | 0.8          | 35.4   | 60                |
| Z802337 - 1 x 200 m | KLA 7-10 (200)  | 2          | 7         | 21     | 10     | 1.1          | 48     | 77                |
| Z802301 - 1 x 200 m | KLA 8-10 (200)  | 2.5        | 8         | 24     | 11     | 1.4          | 63     | 100               |
| Z802302 - 1 x 100 m | KLA 10-10 (200) | 4          | 10        | 30     | 14     | 2.3          | 98     | 160               |
| Z802303 - 1 x 100 m | KLA 13-10 (200) | 6.7        | 13        | 39     | 18     | 3.8          | 166    | 260               |
| Z802304 - 1 x 100 m | KLA 16-10 (200) | 10         | 16        | 48     | 22     | 5.6          | 251    | 402               |
| Z802305 - 1 x 50 m  | KLA 20-10 (200) | 16         | 20        | 60     | 29     | 9.4          | 393    | 630               |
| Z802246 - 1 x 50 m  | KLA 22-10 (200) | 20         | 22        | 66     | 31     | 11.8         | 490    | 806               |
| Z802248 - 1 x 50 m  | KLA 26-10 (200) | 27         | 26        | 78     | 37     | 14.6         | 664    | 1062              |



### Short Link KLA, GrabiQ Grade 10 (400)

**Heat treatment**

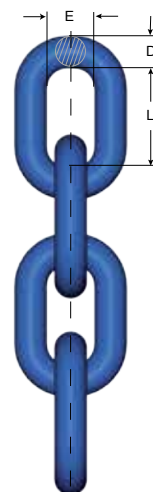
Quenched and tempered.  
Note! For chain grade 10 (400) the maximum in-service temperature is 400 °C.

**Surface treatment**

Painted blue

Note: This chain is marked with "8+" in addition to the marking required by the machine directive.

| Art. no. Box        | Code            | WLL tonnes | D nom. mm | L » mm | E » mm | Weight kgs/m | MPF kN | Breaking force kN |
|---------------------|-----------------|------------|-----------|--------|--------|--------------|--------|-------------------|
| Z802306 - 1 x 200 m | KLA 6-10 (400)  | 1.5        | 6.6       | 18     | 8.9    | 1.0          | 37     | 60                |
| Z802307 - 1 x 200 m | KLA 8-10 (400)  | 2.5        | 8.8       | 24     | 11.2   | 1.7          | 62.5   | 100               |
| Z802308 - 1 x 100 m | KLA 10-10 (400) | 4          | 11.0      | 30     | 14.4   | 2.6          | 100    | 160               |
| Z802309 - 1 x 100 m | KLA 13-10 (400) | 6.7        | 14.3      | 39     | 19.2   | 4.5          | 162    | 260               |
| Z802310 - 1 x 100 m | KLA 16-10 (400) | 10         | 17.3      | 48     | 23.0   | 6.7          | 250    | 402               |



### Short link KLB, Classic Grade 8

**EN 818-2**

**Heat treatment**

Quenched and tempered

**Surface treatment**

Painted black  
Painted yellow

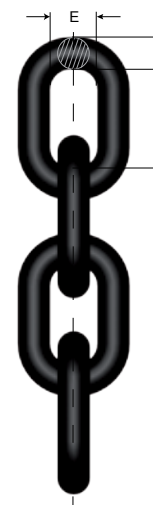
**Marking**

8G

**Charge no.**

SWE

| Art. no. Box        | Code      | WLL tonnes* | D nom. | L  | E   | Weight kgs/m | Manufacturing proof force kN | Breaking force kN |
|---------------------|-----------|-------------|--------|----|-----|--------------|------------------------------|-------------------|
| Z802174 - 1 x 200 m | KLB 6-8E  | 1.1         | 6      | 18 | 8.5 | 0.8          | 28.3                         | 45.2              |
| Z802175 - 1 x 200 m | KLB 7-8E  | 1.5         | 7      | 21 | 10  | 1.1          | 38.5                         | 61.6              |
| Z802176 - 1 x 200 m | KLB 8-8E  | 2.0         | 8      | 24 | 11  | 1.4          | 50.3                         | 80.4              |
| Z802156 - 1 x 100 m | KLB 10-8E | 3.2         | 10     | 30 | 14  | 2.2          | 78.5                         | 126               |
| Z802157 - 1 x 100 m | KLB 13-8E | 5.4         | 13     | 39 | 18  | 3.7          | 133                          | 212               |
| Z802177 - 1 x 100 m | KLB 16-8E | 8.0         | 16     | 48 | 22  | 5.6          | 201                          | 322               |
| Z801203 - 1 x 100 m | KLB 19-8E | 11.6        | 19     | 57 | 26  | 7.8          | 284                          | 454               |
| Z801228 - 1 x 50 m  | KLB 22-8E | 15.5        | 22     | 66 | 30  | 10.6         | 380                          | 608               |
| Z801231 - 1 x 25 m  | KLB 26-8E | 21.6        | 26     | 78 | 35  | 14.8         | 531                          | 849               |
| Z801232 - 1 x 25 m  | KLB 32-8E | 32.0        | 32     | 96 | 43  | 21.6         | 804                          | 1290              |



\*Safety factor 4:1

All dimensions in mm

### Short Link Chain KLFU, Grade 8

**Heat treatment**

Quenched and tempered,  
Stress relieved

**Surface treatment**

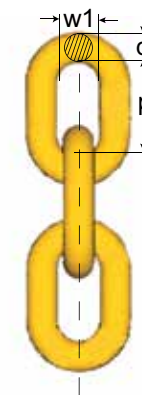
Painted yellow

**Marking**

GF

**Not for lifting purposes.**

| Art. no. | Code      | Link dimensions |     |      | Weight kgs/m | Min. breaking load (tonnes) | Delivery length |
|----------|-----------|-----------------|-----|------|--------------|-----------------------------|-----------------|
|          |           | d nom.          | P » | w1 » |              |                             |                 |
| Z802330  | KLFU-10-8 | 10              | 30  | 14.6 | 2.2          | 12.6                        | 1 x 100 m       |
| Z802331  | KLFU-13-8 | 13              | 39  | 18.4 | 3.7          | 21.4                        | 1 x 100 m       |
| Z801146  | KLFU-16-8 | 16              | 48  | 22.6 | 5.8          | 32.2                        | 1 x 100 m       |
| Z327377  | KLFU-19-8 | 19              | 57  | 26   | 8.0          | 45.4                        | 1 x 100 m       |
| Z327385  | KLFU-22-8 | 22              | 66  | 30   | 11.0         | 61.0                        | 1 x 50 m        |
| Z801505  | KLFU-26-8 | 26              | 78  | 35   | 14.8         | 86.0                        | 1 x 50 m        |



### Mid-link Chain MLFU, Grade 8

**Heat treatment**

Quenched and tempered,  
Stress relieved

**Surface treatment**

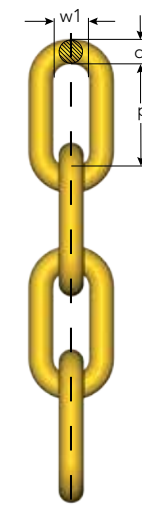
Painted yellow

**Marking**

GF

**Not for lifting purposes.**

| Art. no. | Code      | Link dimensions |        |         | Weight kgs/m | Min. breaking load (tonnes) | Delivery length |
|----------|-----------|-----------------|--------|---------|--------------|-----------------------------|-----------------|
|          |           | d nom. mm       | P » mm | w1 » mm |              |                             |                 |
| Z802332  | MLFU-10-8 | 10              | 40     | 14      | 2.0          | 12.6                        | 1 x 100 m       |
| Z802333  | MLFU-13-8 | 13              | 55     | 20      | 3.3          | 21.4                        | 1 x 100 m       |
| Z800564  | MLFU-16-8 | 16              | 65     | 22      | 5.0          | 32.2                        | 1 x 100 m       |
| Z800476  | MLFU-19-8 | 19              | 75     | 29      | 7.1          | 45.4                        | 1 x 100 m       |
| Z800661  | MLFU-22-8 | 22              | 88     | 30      | 9.4          | 61.0                        | 1 x 50 m        |
| Z801770  | MFLU-26-8 | 26              | 91     | 35      | 13.9         | 86.0                        | 1 x 50 m        |



### Long-link Chain LLU, Grade 8

**Heat treatment**

Quenched and tempered,  
Stress relieved

**Surface treatment**

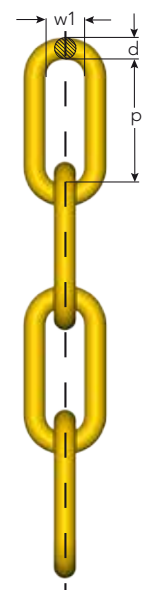
Painted yellow

**Marking**

GF

**Not for lifting purposes.**

| Art. no. | Code     | Link dimensions |     |    | Weight kgs/m | Min. breaking load (tonnes) | Delivery length |
|----------|----------|-----------------|-----|----|--------------|-----------------------------|-----------------|
|          |          | d               | p   | w1 |              |                             |                 |
| Z801933  | LLU-6-8  | 6               | 35  | 10 | 0.6          | 4.5                         | 5 x 100 m       |
| Z801934  | LLU-9-8  | 9               | 53  | 15 | 1.4          | 10.2                        | 4 x 100 m       |
| Z801935  | LLU-11-8 | 11              | 64  | 18 | 2.1          | 15.4                        | 4 x 100 m       |
| Z801936  | LLU-13-8 | 13              | 80  | 22 | 2.9          | 21.4                        | 3 x 100 m       |
| Z802160  | LLU-16-8 | 16              | 100 | 27 | 4.6          | 32.2                        | 1 x 100 m       |
| Z601983  | LLU-19-8 | 19              | 100 | 28 | 6.5          | 45.4                        | 1 x 100 m       |
| Z700526  | LLU-22-8 | 22              | 120 | 36 | 8.7          | 61.0                        | 1 x 50 m        |



\*Safety factor 4:1

All dimensions in mm

### Short Link Chain - KLFZ, Grade 7

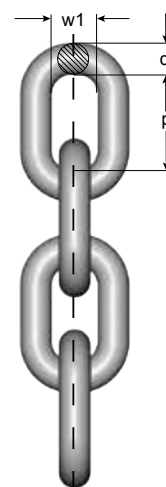
**Heat treatment**  
Quenched and tempered

**Surface treatment**  
Hot Dip Galvanized (HDG)

**Marking**  
GF

**Not for lifting purposes.**

| Art. No | Code      | Link dimensions |      |      | Min. breaking load (tonnes) | Weight kgs/m | Delivery length |
|---------|-----------|-----------------|------|------|-----------------------------|--------------|-----------------|
|         |           | d nom.          | P »m | w1 » |                             |              |                 |
| Z800666 | KLFZ-10-7 | 10              | 30   | 14.6 | 11                          | 2.2          | 1 x 100 m       |
| Z802329 | KLFZ-13-7 | 13              | 39   | 18.4 | 18                          | 3.7          | 1 x 100 m       |
| Z801644 | KLFZ-16-7 | 16              | 48   | 22.6 | 28                          | 5.8          | 1 x 100 m       |
| Z801409 | KLFZ-17-7 | 17              | 48   | 24   | 30                          | 6.4          | 1 x 100 m       |
| Z801407 | KLFZ-19-7 | 19              | 57   | 26   | 40                          | 8.0          | 1 x 100 m       |



### Chain Manufacturing - Quality and Strength Requirements

Chains are divided into grades based on minimum nominal breaking load.

| Chain Grade | Surface treatment   | Code | Minimum breaking load N/mm <sup>2</sup> | Load factors |     |                | Typical use  |
|-------------|---------------------|------|---|--------------|-----|----------------|--|
|             |                     |      |   | WLL          | MPF | Breaking force |  |
| 8           | Yellow U<br>Black B | KL   | 800                                     | 1            | 2.5 | 4              | General lifting (KL),<br>Container lashing (LL).<br>Extra heavy towing (ML), Lashing (KL, LL).<br>Fishing (KL, ML, LL) |
|             |                     | ML   | 800                                     | 1            | 2.5 | 5              |  |
|             |                     | LL   | 800                                     | 1            | 2.5 | 5              |  |
| 10          | Blue A              | KL   | 1000                                    | 1            | 2.5 | 4              | General lifting  |

### Mid-link Chain MLFZ, Grade 7

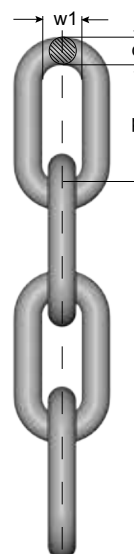
**Heat treatment**  
Quenched and tempered

**Surface treatment**  
Hot Dip Galvanized (HDG)

**Marking**  
GF

**Not for lifting purposes.**

| Art. No | Code      | Link dimensions |     |      | Min. breaking load (tonnes) | Weight kgs/m | Delivery length |
|---------|-----------|-----------------|-----|------|-----------------------------|--------------|-----------------|
|         |           | d nom.          | P » | w1 » |                             |              |                 |
| Z801561 | MLFZ-10-7 | 10              | 40  | 14   | 11                          | 2.0          | 1 x 100 m       |
| Z802335 | MLFZ-13-7 | 13              | 55  | 20   | 18                          | 3.3          | 1 x 100 m       |
| Z801645 | MLFZ-16-7 | 16              | 65  | 22   | 28                          | 5.0          | 1 x 100 m       |
| Z801477 | MLFZ-19-7 | 19              | 75  | 29   | 40                          | 7.1          | 1 x 100 m       |



### Testing and Quality Control- GrabiQ & Classic Chain (Grade 10 & 8)

In each step of the manufacturing of the chain, our systematic quality monitoring will ensure the highest safety and the longest life span in the product. Here are some especially important aspects of quality:

#### Material

The incoming material is supplied with test certificates only from qualified manufacturers and according to our stated material specifications.

#### Manufacturing

During forming and welding, the operators continuously control that the links meet the specified dimensions both before and after welding. Single link samples are continuously mandrel tested on the weld. Shape, dimensions and deburring are then inspected visually.

Sample lengths are heat treated and then destruction load tested. Following these tests, the chain is heat treated.

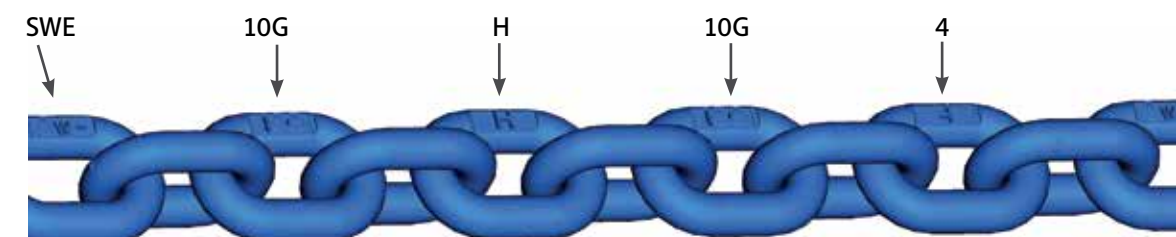
Hardening and tempering is carried out continuously in computer controlled induction furnaces with regular samplings.

#### Proof Load

The entire chain is test loaded. The test force for short link chain is 2.5 times the permitted working load limit. This gives the chain high safety in use. The chain is then visually inspected and cut into delivery lengths. A sample is taken from every length and tested to destruction. Dimensions and shape are also checked. All results are documented.

#### Marking and traceability

The international standards for lifting chain require that the chain is marked with Grade and Manufacturers ID. On our chain we stamp "SWE - 10G - H - 10G - 4", where the "H" and the "4" is the combination for the traceability code. In case of the unlikely event of chain failure, we can trace the specific chain link back to the very batch and raw material as well as the year and place of manufacture. Each individual delivery also has its unique batch number.



### Long Link Chain LLZ, Grade 6/7

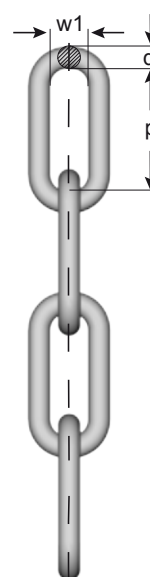
**Heat treatment**  
Quenched and tempered

**Surface treatment**  
Hot Dip Galvanized (HDG)

**Marking**  
GF

**Not for lifting purposes.**

| Art. No | Code     | Link dimensions |     |      | Min. breaking load (tonnes) | Weight kgs/m | Delivery length |
|---------|----------|-----------------|-----|------|-----------------------------|--------------|-----------------|
|         |          | d nom.          | p » | w1 » |                             |              |                 |
| Z487081 | LLZ-6-7  | 6               | 35  | 10   | 3.9                         | 0.6          | 1 x 100 m       |
| Z801553 | LLZ-9-7  | 9               | 53  | 15   | 9                           | 1.4          | 1 x 100 m       |
| Z360314 | LLZ-11-7 | 11              | 64  | 18   | 13                          | 2.1          | 4 x 100 m       |
| Z800676 | LLZ-13-6 | 13              | 80  | 22   | 16                          | 2.9          | 3 x 100 m       |
| Z801567 | LLZ-16-6 | 16              | 100 | 27   | 24                          | 4.6          | 1 x 100 m       |
| Z801458 | LLZ-19-6 | 19              | 100 | 28   | 34                          | 6.5          | 1 x 100 m       |
| Z801887 | LLZ-22-6 | 22              | 120 | 36   | 46                          | 8.7          | 1 x 50 m        |



\*Safety factor 4:1

All dimensions in mm





# The New Lifting Point Family

In June 2015 Gunnebo Industries introduced three new lifting points as well as a significantly improved existing lifting point. The range will fit most lifting and lashing applications and can offer a full system, from masterlink to lifting point.

Choosing the right lifting point for your operation can be tricky, you know as well as we do that most lifting points can be used for a lot of purposes. But in order to give some guidance, and what we consider best practice, a cross-chart has been created (as seen on next page) to be used as indication to which lifting point that might be best suited for your specific purpose.

## Rotating Eye Lifting Point - RELP

The RELP is a compact and robust lifting point, ideal for top-mounting and when it is important to have quick and easy on-hooking. The bolt has a hexagon socket which makes it easy to mount and dismount but an even better feature is the marking. On the bolt itself information such as the working load limit, mounting torque and manufacturing ID is stamped so it's always available for the operator, should the conditions for the operation change.

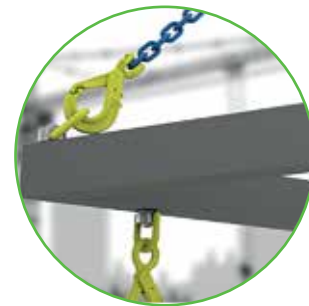
The RELP will automatically adjust to the loading direction which decreases the risk to load it incorrectly and endangering the lifting operation. For sensitive load surfaces the RELP is ideal, as the connecting sling hook will be positioned mainly parallel to the load surface, thus completely avoiding the hook causing damage on impact on the load.



## Rotating Lifting Point - RLP

The RLP has an easily dismountable D-ring to enable assembly of roundsling, master link or hook directly onto the lifting point.

RLP has a hexagon screw to make it easy to disassemble/assemble with a wrench. The bolt is also clearly marked with information such as working load limit, mounting torque and manufacturer ID so it's always available to the operator. The RLP rotates 360° and pivots 180°, making it strong, flexible and reliable.



## De-centered Lifting Point - DLP

The design of the DLP allows the link to be folded over the housing when idle, allowing the lifting point to be almost completely stowed away when not in use.

The closed, oblong link is also equipped with a "stay-up"-function for easy on-hooking, (sizes up to M24) especially when there is limited space. This saves both the load from damage due to impacts from the hook, as well as making rigging fast and easy. The DLP is ideal in narrow spaces, such as corners or edge position, as the housing has a compact design.



## Ball-bearing Lifting Point - BLP

The BLP is a very versatile lifting point and can safely be used for most applications. The ballbearings in the BLP allow the load to be rotated during the lift, which is especially good when maintenance is needed on heavy tools and other types of equipment.

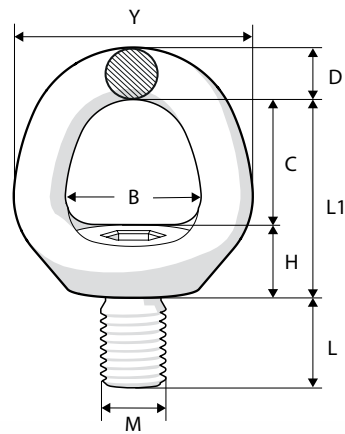
If the load surface is sensitive to impacts or scratches, the BLP is a good choice as it builds out from the load which makes it less likely that the lifting equipment will come in contact with it causing damage. The housing of the BLP has a hexagon shape for easy mounting and dismounting.



|                                       | RELP | RLP | DLP | BLP |
|---------------------------------------|------|-----|-----|-----|
| Tight space                           | ✓    |     | ✓   | ✓   |
| Limited height (effective length)     | ✓    | ✓   |     |     |
| Vertical lift                         | ✓    | ✓   |     | ✓   |
| Angular lift                          |      | ✓   | ✓   | ✓   |
| Vertical rotation under load          |      |     |     | ✓   |
| Tilting under load                    |      | ✓   | ✓   | ✓   |
| Sensitive load surface                |      |     |     | ✓   |
| Single part lift                      | ✓    | ✓   |     | ✓   |
| Multiple part lift                    |      | ✓   | ✓   | ✓   |
| Integrated combination (hook or link) |      | ✓   |     |     |

This chart is intended to give guidance in choosing the right lifting point for your operation and is not rules for usage. For more advice contact your closest Gunnebo Industries dealer.





Rotating Eye Lifting Point RELP

Table with columns: Art. no., Code, Dimensions in mm (B, C, D, H, L, L1, M, Y), Weight kgs. Lists various RELP models and their specifications.



RELP with UNC thread

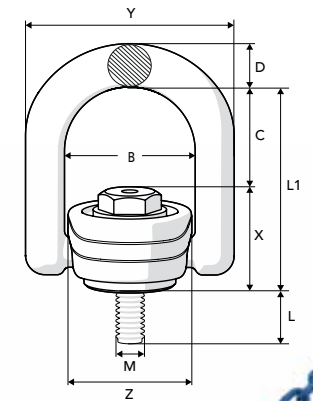
Table with columns: Art. no., Code, Dimensions in m (B, C, D, H, L, L1, Y), M inch, Weight kgs. Lists RELP models with UNC threads.

Rotating Lifting Point RLP

Table with columns: Art. no., Code, Dimensions in mm (B, C, D, L, L1, M, X, Y, Z), Weight kgs. Lists various RLP models.

RLP with UNC thread

Table with columns: Art. no., Code, Dimensions in mm (B, C, D, L, L1, X, Y, Z), M inch, Weight kgs. Lists RLP models with UNC threads.



Disassembly of the RLP is made easy by just folding the D-ring forward and push down.



Extra Long Bolt for RLP \*\*

Table with columns: Art. no., Bolt, Protrusion L (mm), Weight (kgs). Lists extra long bolts for RLP models.

Working Load Limits\* - RLP

Table with columns: Symmetric Load (tonnes), No. of legs, Angle β, Tightening torque, Spanner size. Includes diagrams for load configurations.

Working Load Limits\* - RELP

Table with columns: Symmetric Load (tonnes), No. of legs, Angle β, Tightening torque, Allen key. Includes diagrams for load configurations.

\*Safety factor 4:1

\*Safety factor 4:1

\*\* When using extra long bolt, make sure to use nut/washer of min. strength rating 10.9, ISO 898-1.

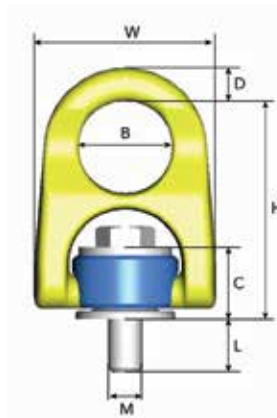


### Rotating Lifting Point ERLP

Slim design to fit in confined spaces.

Note! ERLP will be cancelled from our product range during 2016.

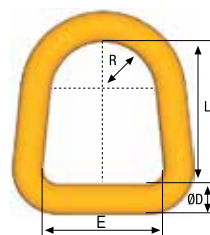
| Art. no. | Code        | L  | M   | B   | D  | C  | H    | W  | Weight (kgs) |
|----------|-------------|----|-----|-----|----|----|------|----|--------------|
| Z101260  | ERLP-M8-10  | 15 | M8  | Ø27 | 10 | 20 | 63   | 52 | 0.2          |
| Z101261  | ERLP-M10-10 | 20 | M10 | Ø27 | 10 | 20 | 63   | 52 | 0.2          |
| Z101252  | ERLP-M12-10 | 19 | M12 | Ø38 | 15 | 31 | 91.8 | 73 | 0.8          |
| Z101253  | ERLP-M16-10 | 24 | M16 | Ø38 | 15 | 31 | 91.8 | 73 | 0.8          |



### Master Link D

| Art. no. | Code   | WLL tonnes* | E  | D  | L  | R  | Weight kgs |
|----------|--------|-------------|----|----|----|----|------------|
| Z700877  | D-14-8 | 2.5         | 55 | 14 | 65 | 24 | 0.4        |
| Z700878  | D-17-8 | 4           | 64 | 17 | 62 | 29 | 0.5        |
| Z700880  | D-22-8 | 8           | 76 | 22 | 90 | 33 | 1          |

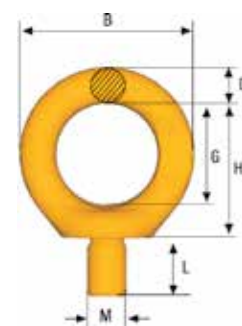
The load bearing width must be at least 0.5 x E



### Eye Lifting Point ELP

| Art. no. | Code     | WLL tonnes* | B   | D  | G  | H  | L  | M   | Weight kgs |
|----------|----------|-------------|-----|----|----|----|----|-----|------------|
| Z100434  | ELP-16-8 | 1**         | 72  | 16 | 42 | 55 | 24 | M16 | 0.4        |
| Z100435  | ELP-20-8 | 1.5**       | 72  | 16 | 42 | 58 | 30 | M20 | 0.4        |
| Z100436  | ELP-24-8 | 2**         | 88  | 19 | 48 | 69 | 36 | M24 | 0.9        |
| Z100437  | ELP-30-8 | 3**         | 106 | 22 | 60 | 84 | 45 | M30 | 1.4        |

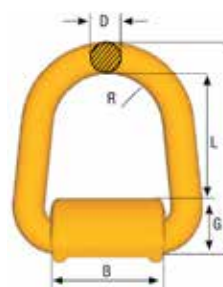
\*\* In case of 1-leg application where loading is limited to straight loading in the direction of thread (no bending force) it is possible to use ELP with four times higher WLL. Note! Threaded depths need to be at least 1xM for steel, 1,25xM for cast iron and 2xM for aluminium alloy.



### Weldable Lifting Point WLP

| Art. no. | Code   | WLL tonnes* | B  | D  | G  | L  | R  | T   | Weight kgs |
|----------|--------|-------------|----|----|----|----|----|-----|------------|
| Z700900  | WLP-1T | 1           | 50 | 14 | 27 | 53 | 24 | 95  | 0.5        |
| Z700901  | WLP-3T | 3           | 58 | 17 | 34 | 48 | 29 | 97  | 0.8        |
| Z700902  | WLP-5T | 5           | 64 | 22 | 41 | 73 | 33 | 135 | 1.8        |

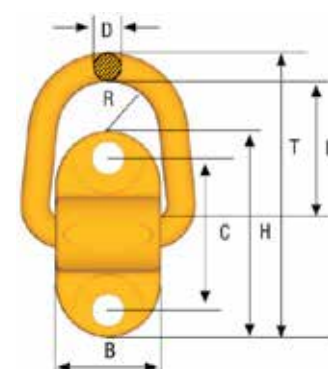
Supplied with spring for stay up function



### Screw-on Lifting Point SLP

| Art. no. | Code   | WLL tonnes* | B  | C   | D  | H   | L  | M   | T   | R  | Weight kgs |
|----------|--------|-------------|----|-----|----|-----|----|-----|-----|----|------------|
| Z700988  | SLP-1T | 1           | 50 | 72  | 14 | 98  | 55 | M14 | 139 | 24 | 0.8        |
| Z700987  | SLP-3T | 3           | 58 | 84  | 17 | 114 | 50 | M16 | 144 | 29 | 1.3        |
| Z700986  | SLP-5T | 5           | 64 | 116 | 22 | 160 | 74 | M20 | 203 | 33 | 2.6        |

Supplied with spring for stay up function



### Working Load Limits (tonnes) for ERLP

|             | 1 leg |      | 2 legs |      | 2 symmetric |        | 3 & 4 symmetric |        |
|-------------|-------|------|--------|------|-------------|--------|-----------------|--------|
|             | 0°    | 90°  | 0°     | 90°  | 0-45°       | 45-60° | 0-45°           | 45-60° |
| No. of legs | 1     | 1    | 2      | 2    | 2 symmetric |        | 3 & 4 symmetric |        |
| β           | 0°    | 90°  | 0°     | 90°  | 0-45°       | 45-60° | 0-45°           | 45-60° |
| Load factor |       | 1    |        | 2    | 1.4         | 1      | 2.1             | 1.5    |
| M8-10       | 0.60  | 0.30 | 1.20   | 0.60 | 0.42        | 0.30   | 0.63            | 0.45   |
| M10-10      | 1.00  | 0.50 | 2.00   | 1.00 | 0.70        | 0.50   | 1.05            | 0.75   |
| M12-10      | 1.50  | 0.75 | 3.00   | 1.50 | 1.00        | 0.75   | 1.60            | 1.13   |
| M16-10      | 3.00  | 1.50 | 6.00   | 3.00 | 2.10        | 1.50   | 3.15            | 2.25   |

In case of asymmetric loading we recommend following loading:

- 2-leg as corresponding 1-leg
- 3- or 4-leg as corresponding 2-leg

### Working Load Limits (tonnes) for ELP / WLP / SLP

| Typ      | WLL tonnes* | 1-leg           |                    | 2-leg           |                    | 3- and 4-leg |  |
|----------|-------------|-----------------|--------------------|-----------------|--------------------|--------------|--|
|          |             | α 0-90° β 0-45° | α 90-120° β 45-60° | α 0-90° β 0-45° | α 90-120° β 45-60° |              |  |
| ELP-16-8 | 1**         | 1.4             | 1                  | 2.1             | 1.5                |              |  |
| ELP-20-8 | 1,5**       | 2.1             | 1.5                | 3.2             | 2.3                |              |  |
| ELP-24-8 | 2**         | 2.8             | 2                  | 4.2             | 3                  |              |  |
| ELP-30-8 | 3**         | 4.2             | 3                  | 6.3             | 4.5                |              |  |
| WLP-1T   | 1           | 1.4             | 1                  | 2.1             | 1.5                |              |  |
| WLP-3T   | 3           | 4.2             | 3                  | 6.3             | 4.5                |              |  |
| WLP-5T   | 5           | 7               | 5                  | 10.5            | 7.5                |              |  |
| SLP-1T   | 1           | 1.4             | 1                  | 2.1             | 1.5                |              |  |
| SLP-3T   | 3           | 4.2             | 3                  | 6.3             | 4.5                |              |  |
| SLP-5T   | 5           | 7               | 5                  | 10.5            | 7.5                |              |  |

\*\*Note! The above loads apply to normal usage and equally loaded legs. For asymmetric loaded chain slings, the following is recommended:

- A two-legged system is rated as a single-legged system.
- A three- or four-legged system is rated as a two-legged system.



---

Stainless Steel Chains  
and Components





## WOX Chain inox

Clean, tidy and hard-working.

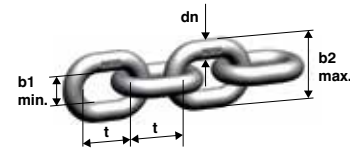
This stainless steel lifting chain is made from high-grade stainless steel, with a load capacity that is 25 % higher than that of G5 lifting chains. The chains are tested at 100 % of their load capacity, which is an impressive 12,000 kg! The chain is electrically welded for an extra-clean finish, stamped and with a higher resistance to acids and caustics than the standard lifting chains G8, G10 and G12.

The chain is guaranteed to be compatible with the Connex CWI links, with dimensions that are similar to DIN 5687-1 and EN 818-2. The stamp makes the chains clearly identifiable.

The WOX chain is particularly suited for use in water and wastewater applications. It can also be used in connection with chemicals and food products; however, restrictions will apply.



| WOX Chain inox | Code      | Nominal diameter dn [mm] | Standard-delivery length [m] | Pitch t [mm] | Inside width b1 min. [mm] | Outside width b2 max. [mm] | WLL [kg] | Breaking force [kN] | Weight [kg/m] |
|----------------|-----------|--------------------------|------------------------------|--------------|---------------------------|----------------------------|----------|---------------------|---------------|
|                | WOX 4-6   | 4                        | 50 m                         | 12           | 6.2                       | 14.8                       | 400      | 16.0                | 0.38          |
|                | WOX 5-6   | 5                        | 50 m                         | 15           | 7.5                       | 18.5                       | 630      | 25.0                | 0.58          |
|                | WOX 6-6   | 6                        | 50 m                         | 18           | 8.7                       | 20.9                       | 900      | 37.5                | 0.82          |
|                | WOX 7-6   | 7                        | 50 m                         | 21           | 9.5                       | 25.2                       | 1,250    | 50.0                | 1.11          |
|                | WOX 8-6   | 8                        | 50 m                         | 24           | 10.8                      | 28.6                       | 1,600    | 63.0                | 1.43          |
|                | WOX 10-6  | 10                       | 50 m                         | 30           | 13.5                      | 36.0                       | 2,500    | 100.0               | 2.25          |
|                | WOX 13-6  | 13                       | 25 m                         | 39           | 17.5                      | 46.8                       | 4,250    | 170.0               | 3.77          |
|                | WOX 16-6  | 16                       | 25 m                         | 48           | 21.5                      | 57.6                       | 6,300    | 250.0               | 5.62          |
|                | WOX 20-5  | 20                       | -                            | 60           | 27                        | 72                         | 8,000    | 314.0               | 9.29          |
|                | WOX 26-4+ | 26                       | -                            | 78           | 35.0                      | 93.6                       | 12,000   | 471.0               | 16.20         |



## AWI Master Link

Doubles up as a dependable end link.

High-grade stainless steel yields a result that outshines the rest: This stainless master link is electrically welded for a clean finish, stamped and suitable for both I- and II-legged chains and wire rope slings (similar to DIN 3088- 1989). The master link may also be used in VWI four-legged assemblies and as an end link. Its dimensions are similar to DIN 5688-1 and it is tested at 100 % of its load capacity. A particular bonus is the higher resistance to acids and caustics compared to the standard loading rings G8, G10 and G12. The stamp makes the master link clearly identifiable. The master link also bears the CE mark.



The AWI Master link is particularly suited for use in water and wastewater applications. It can also be used in connection with chemicals and food products; however, restrictions will apply.

| AWI Master link | Code     | WLL 0-45° [kg] | Usable up to sling hooks following DIN 15401 No. | d [mm] | t [mm] | w [mm] | s [mm] | Weight [kg/pc.] | For I-leg chain slings | For II-leg chain slings |
|-----------------|----------|----------------|--|--------|--------|--------|--------|-----------------|------------------------|-------------------------|
|                 | AWI 8-6  | 560            | 0.5  | 8      | 60     | 35     | -      | 0.08            | 4                      | 4                       |
|                 | AWI 10-6 | 850            | 1.6  | 10     | 80     | 50     | -      | 0.14            | 5                      | 5                       |
|                 | AWI 13-6 | 1,600          | 2.5  | 13     | 110    | 60     | 10     | 0.34            | 6/7/8                  | 6                       |
|                 | AWI 16-6 | 2,600          | 2.5  | 16     | 110    | 60     | 14     | 0.53            | 10                     | 7/8                     |
|                 | AWI 18-6 | 3,500          | 5  | 18     | 135    | 75     | 14     | 0.92            | -                      | 10                      |
|                 | AWI 22-6 | 6,300          | 6  | 23     | 160    | 90     | 17     | 1.60            | 13/16                  | 13                      |
|                 | AWI 26-6 | 8,900          | 8  | 27     | 180    | 100    | 20     | 2.46            | 20                     | 16                      |
|                 | AWI 32-6 | 13,200         | 10   | 32     | 200    | 110    | 26     | 4.14            | -                      | 20                      |
|                 | AWI 36-6 | 14,700         | 16   | 36     | 260    | 140    | 29     | 6.22            | -                      | -                       |
|                 | AWI 45   | 12,000         | -  | 45     | 340    | 180    | **     | 12.82           | 26                     | -                       |



Custom-made, also with flattening available.

## BWI Transition Link

Electrically welded for an extra-clean finish.

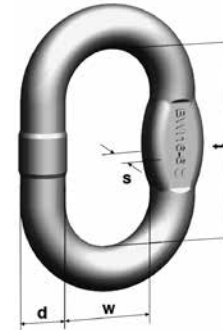
A higher resistance to acids and caustics compared to the standard transition links G8, G10 and G12 is just one of the many benefits that make this stamped transition link truly remarkable. The use of high-grade stainless steel also ensures that this electrically welded transition and securing link will never rust.

The stamp and the CE mark ensure that the product is clearly identifiable. The transition link is part of welded assemblies, may also be used as an end link and is tested at 100 % of its maximum load capacity. Its dimensions are similar to DIN 5688-1.



The outstanding quality of this transition link is also reflected in its wide range of possible applications: It may be used as a connecting link for assembling I- to IV-strand assemblies in welded systems as well as an end link. In addition, it is ideally suited for use in water and wastewater applications and can also be used in connection with chemicals and food products; however, restrictions will apply.

| BWI Transition link | Code     | WLL 0-45° [kg] | d [mm] | t [mm] | w [mm] | s [mm] | Weight [kg/pc.] | For I-leg chain slings | For II-leg chain slings |
|---------------------|----------|----------------|--------|--------|--------|--------|-----------------|------------------------|-------------------------|
|                     | BWI 7-6  | 900            | 7      | 36     | 16     | -      | 0.03            | 5/6                    | 5/6                     |
|                     | BWI 9-6  | 1,250          | 9      | 44     | 20     | -      | 0.07            | 7                      | 7                       |
|                     | BWI 10-6 | 1,600          | 10     | 44     | 20     | -      | 0.09            | 8                      | 8                       |
|                     | BWI 13-6 | 2,500          | 13     | 54     | 25     | 10     | 0.19            | 10                     | 10                      |
|                     | BWI 16-6 | 4,250          | 16     | 70     | 34     | 14     | 0.36            | 13                     | 13                      |
|                     | BWI 20-6 | 6,300          | 20     | 85     | 40     | 16     | 0.71            | 16                     | 16                      |
|                     | BWI 22-6 | 8,000          | 23     | 115    | 50     | 17     | 1.16            | 20                     | -                       |
|                     | BWI 26-6 | 10,070         | 27     | 140    | 65     | 20     | 1.92            | -                      | -                       |
|                     | BWI 32-6 | 12,000         | 32     | 150    | 70     | 26     | 3.18            | 26                     | -                       |



Custom-made, also with flattening available.

## VWI Master Link Assembly

Consistent performance.

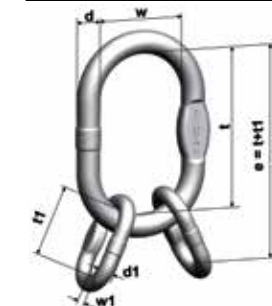
This stainless steel chain sling is electrically welded for a clean finish, stamped and ideally suited for assembling III- and IV-legged chain slings in welded or assembled systems. The dimensions are similar to DIN 5688-1.

The VWI Master link assembly is tested at 100 % of its load capacity. It is made from high-grade stainless steel with a higher resistance to acids and caustics than the standard four-legged chain slings G8, G10 and G12.

It is ideally suited for use in water and wastewater applications and can also be used in connection with chemicals and food products; however, restrictions will apply. The stamp and the CE mark ensure that the product is clearly identifiable.



| VWI Master link assembly | Code      | Consisting of         | Usable up to sling hooks following DIN 15401 No. | WLL 0-45° [kg] | e [mm] | d [mm] | t [mm] | w [mm] | d1 [mm] | t1 [mm] | w1 [mm] | Weight [kg/pc.] |
|--------------------------|-----------|-----------------------|--|----------------|--------|--------|--------|--------|---------|---------|---------|-----------------|
|                          | VWI 4-6   | AWI 10-6 + 2 BWI 9-6  | 1.6  | 840            | 124    | 10     | 80     | 50     | 9       | 44      | 20      | 0.28            |
|                          | VWI 5-6   | AWI 13-6 + 2 BWI 10-6 | 2.5  | 1,300          | 154    | 13     | 110    | 60     | 10      | 44      | 20      | 0.52            |
|                          | VWI 6/7-6 | AWI 16-6 + 2 BWI 13-6 | 5  | 2,600          | 164    | 16     | 110    | 60     | 13      | 54      | 25      | 0.91            |
|                          | VWI 8-6   | AWI 18-6 + 2 BWI 16-6 | 6  | 3,350          | 205    | 18     | 135    | 75     | 16      | 70      | 34      | 1.64            |
|                          | VWI 10-6  | AWI 22-6 + 2 BWI 20-6 | 8  | 5,250          | 245    | 23     | 160    | 90     | 20      | 85      | 40      | 3.02            |
|                          | VWI 13-6  | AWI 26-6 + 2 BWI 22-6 | 10   | 8,900          | 295    | 27     | 180    | 100    | 23      | 115     | 50      | 4.78            |
|                          | VWI 16-6  | AWI 32-6 + 2 BWI 26-6 | 16   | 13,200         | 340    | 32     | 200    | 110    | 27      | 140     | 65      | 7.98            |



Custom-made, also with flattening available.  
Number close to code constitutes chain, used in combination with product.

**pewag**

## CWI Connex Connecting Link

For a seamless connection.

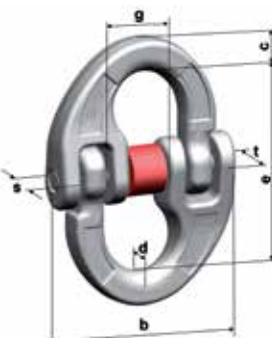
This stainless steel connecting link is drop-forged and stamped and consists of two symmetrical halves made from high-grade stainless steel. Its labour-intensive manufacturing process gives the product its outstanding quality. The connecting link may be divided and used for the universal assembly of chain slings, master links, master link assemblies, shortenings, shackles and other accessories and is guaranteed to be compatible with all pewag winner inox components of the same nominal size.

The suspension bolt is locked by a stainless steel coil spring (mat. 14571) with a synthetic sleeve. The bolt and the shell are available as spare parts.

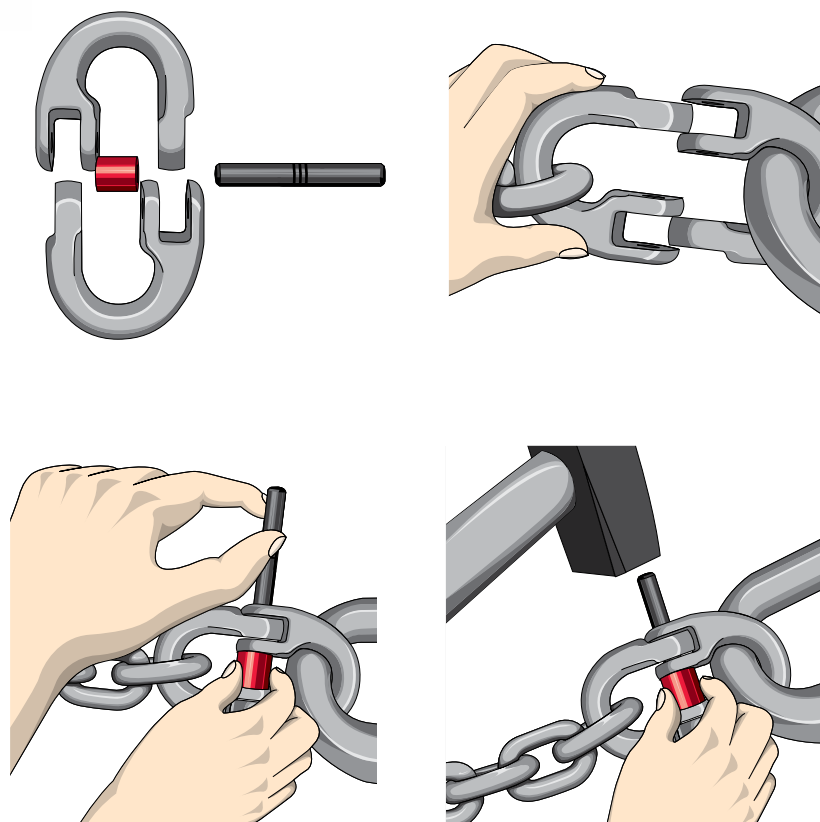
The manufacturing process of the CWI Connex connecting link is similar to EN 1677-1. The product is suitable for straight pulling only; the simultaneous application of loads by two or more legs must be avoided. After the universally usable connecting link has been assembled and disassembled three times, it is recommended to use a new bolt and a new shell, to be mounted securely by a professional, to ensure that the quality of the product remains unimpaired. CBHWI spare part sets are available.

It is ideally suited for use in water and wastewater applications and can also be used in connection with chemicals and food products; however, restrictions will apply. The stamp and the CE mark ensure that the product is clearly identifiable.



| CWI Connex connecting link   | Code     | WLL [kg] | e [mm] | c [mm] | s [mm] | t [mm] | d [mm] | b [mm] | g [mm] | Weight [kg/pc.] |
|--|----------|----------|--------|--------|--------|--------|--------|--------|--------|-----------------|
|  | CWI 5-6  | 630      | 36     | 7      | 10     | 11     | 7      | 34     | 13     | 0.06            |
|  | CWI 7-6  | 1,250    | 54     | 9      | 13     | 14     | 9      | 51     | 17     | 0.14            |
|  | CWI 10-6 | 2,500    | 73     | 13     | 18     | 18     | 13     | 70     | 25     | 0.37            |
|  | CWI 13-6 | 4,250    | 92     | 17     | 23     | 25     | 17     | 86     | 29     | 0.76            |
|  | CWI 16-6 | 6,300    | 104    | 21     | 32     | 28     | 20     | 105    | 37     | 1.41            |

Number close to code constitutes chain, used in combination with product.



## HSWI Eye Sling Hook


The new face of resilience.

Like all pewag elements, this stainless steel eye sling hook is the result of a sophisticated manufacturing process. Using high-grade stainless steel, the hook is drop-forged and stamped. The compact design of the hook ensures the highest possible load capacity while maintaining a minimum product weight. The hook provides impact for protection for the safety latch, a large hook mouth and an extra-wide hook point to prevent accidental hooking into the chain. Due to the flat section on the eye, the hook is also compatible with alternative connecting systems.

This eye sling hook provides excellent directional stability and perfect guidance of the safety trap. It is particularly suited for the assembly of welded and assembled rope lashings. The safety trap engages with the hook point, which provides an effective protection against lateral movements. Forged inspection marks that facilitate the visual recognition of the discard criteria complete this outstanding product.

The manufacturing process is similar to EN 1677-2. The stamp and the CE mark ensure that the product is clearly identifiable. The safety latch assembly is available as spare part SFGWI. Preferred areas of application are water and wastewater applications and the product can also be used in connection with chemicals and food products; however, restrictions will apply.



| HSWI Eye sling hook  | Code       | WLL [kg] | e [mm] | h [mm] | a [mm] | d1 [mm] | d2 [mm] | g1 [mm] | b [mm] | Weight [kg/pc.] |
|--|------------|----------|--------|--------|--------|---------|---------|---------|--------|-----------------|
|  | HSWI 5/6-6 | 900      | 84     | 20     | 14     | 21      | 8       | 22      | 67     | 0.25            |
|  | HSWI 7/8-6 | 1,600    | 112    | 29     | 20     | 27      | 13      | 32      | 98     | 0.70            |
|  | HSWI 10-6  | 2,500    | 133    | 33     | 28     | 37      | 15      | 39      | 115    | 1.35            |
|  | HSWI 13-6  | 4,250    | 172    | 43     | 35     | 48      | 18      | 51      | 147    | 2.60            |
|  | HSWI 16-6  | 6,300    | 213    | 51     | 44     | 55      | 24      | 66      | 182    | 4.80            |

Number close to code constitutes chain, accessories in combination with product.







## VLWI Chain Shortener

Safety is key.

This corrosion-resistant chain shortener is manufactured from high-grade stainless steel and has a welded-in BWI transition link for the simple, effortless link-by-link shortening of stainless steel chains. In addition to being extremely convenient in its application, the shortener also offers the benefit of easy retrofitting in assembled systems and ensures that the chain cannot fall out even when it is shortened, as its proper weight will always lock it in place. The stamp and CE mark ensure that the product is clearly identifiable.

Preferred areas of application for the VLWI shortener are water and wastewater applications and the product can also be used in connection with chemicals and food products; however, restrictions will apply and we recommend that you contact the manufacturer for advice prior to exposing the product to such use.



| VLWI Chain shortener | Code       | WLL [kg] | e [mm] | e1 [mm] | a [mm] | d [mm] | d1 [mm] | g [mm] | Weight [kg/pc.] |
|----------------------|------------|----------|--------|---------|--------|--------|---------|--------|-----------------|
|                      | VLWI 5/6-6 | 900      | 80     | 114     | 52     | 16     | 26      | 8      | 0.22            |
|                      | VLWI 7/8-6 | 1,600    | 111    | 156     | 68     | 22     | 34      | 11     | 0.57            |
|                      | VLWI 10-6  | 2,500    | 133    | 183     | 86     | 27     | 40      | 12     | 1.06            |
|                      | VLWI 13-6  | 4,250    | 169    | 242     | 108    | 32     | 52      | 16     | 2.20            |
|                      | VLWI 16-6  | 6,300    | 204    | 284     | 134    | 38     | 64      | 20     | 4.16            |



Number close to code constitutes chain, accessories in combination with product.



Correct application



Correct application



Correct application



Wrong application

## VAWI Special master link assembly for wire ropes – G5

One for all.

With its flattened transition links, this stainless steel master link assembly for wire ropes opens up universal connection possibilities. If safety is your primary concern, you can't go wrong with this IV-legged master link assembly with extra-large transition links to create III- and IV-legged wire rope slings in the welded or assembled system. The assembly is wide enough to fit two rope thimbles per transition link and is electrically welded and stamped for an extra-clean finish.

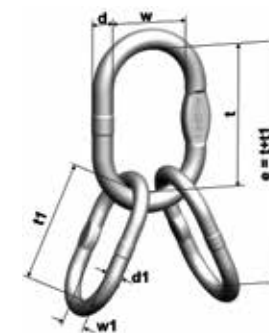
The manufacturing process of this corrosion-resistant, grade 5 master link assembly is similar to DIN 5688-1 and DIN 3088-1989.

It is tested to 100 % of its maximum load capacity. The stamp and CE mark ensure that the product is clearly identifiable.

Preferred areas of application for the VAWI IV-legged master link assembly G5 are water and wastewater applications and the product can also be used in connection with chemicals and food products; however, restrictions will apply and we recommend that you contact the manufacturer for advice prior to exposing the product to such use.



| VAWI Special master link assembly for wire ropes – G5 | Code    | Consisting of     | Usable up to sling hooks following DIN 15401 No. | WLL 0-45° [kg] | e [mm] | d [mm] | t [mm] | w [mm] | d1 [mm] | t1 [mm] | w1 [mm] | Weight [kg/pc.] |
|---|---------|-------------------|--|----------------|--------|--------|--------|--------|---------|---------|---------|-----------------|
|   | VAWI 6  | AWI 18 + 2 AWI 13 | 2.5  | 1,600          | 245    | 19     | 135    | 75     | 13      | 110     | 60      | 1.60            |
|   | VAWI 7  | AWI 18 + 2 AWI 16 | 5  | 2,100          | 245    | 19     | 135    | 75     | 16      | 110     | 60      | 1.98            |
|   | VAWI 8  | AWI 22 + 2 AWI 18 | 6  | 3,000          | 295    | 23     | 160    | 90     | 19      | 135     | 75      | 3.44            |
|   | VAWI 10 | AWI 26 + 2 AWI 22 | 8  | 4,800          | 340    | 27     | 180    | 100    | 23      | 160     | 90      | 5.66            |
|   | VAWI 13 | AWI 32 + 2 AWI 26 | 10   | 7,100          | 380    | 33     | 200    | 110    | 27      | 180     | 100     | 9.06            |
|   | VAWI 16 | AWI 36 + 2 AWI 32 | 16   | 10,500         | 460    | 36     | 260    | 140    | 33      | 200     | 110     | 14.50           |



Number close to code constitutes chain, used in combination with product and attribution of ropes under construction of WLL in accordance of relevant rules of rope slings.





## SSWI Safety Shackle


Withstands any vibrations.

Yet another quality product made from high-grade steel that is forged, stamped and tested to within an inch of its life before it is put to use. This stainless steel safety shackle with a reinforced suspension bolt is designed for use as an end fitting in chain and wire rope slings and in connection with pump chains for the lifting of submersible pumps and breathers, where maximum safety is key. The product comes with a safety mechanism to protect against unintentional release. Please note that it cannot be mounted directly onto the chain.

If used correctly, the SSWI Safety shackle easily withstands vibrations. Each of these safety products bears the CE mark and has a code on the bolt and pins for added traceability.

Preferred areas of application for the shackle are water and wastewater applications and the product can also be used in connection with chemicals and food products; however, restrictions will apply and we recommend that you contact the manufacturer for advice prior to exposing the product to such use.



| SSWI Safety shackle  | Code          | WLL [kg] | e [mm] | a [mm] | b [mm] | d [mm] | d1 [mm] | c [mm] | Weight [kg/pc.] |
|--|---------------|----------|--------|--------|--------|--------|---------|--------|-----------------|
|  | SSWI 0,5 t-S  | 500      | 33     | 8      | 18     | 8      | 9       | 18     | 0.07            |
|  | SSWI 1,25 t-S | 1,250    | 40     | 12     | 25     | 12     | 13      | 25     | 0.22            |
|  | SSWI 2 t-S    | 2,000    | 60     | 16     | 32     | 16     | 17      | 32     | 0.52            |
|  | SSWI 3,2 t-S  | 3,200    | 78     | 19     | 41     | 19     | 21      | 47     | 0.80            |
|  | SSWI 5 t-S    | 5,000    | 109    | 25     | 56     | 25     | 29      | 60     | 2.2             |
|  | SSWI 26-C     | 13,000   | 152    | 34     | 76     | 34     | 38      | 75     | 7               |

Other sizes and special models available on request! On request also stronger shackles available.

**Bolt safety mechanism:**

S = with safety splint C = with bolt adhesive

## CBHWI bolts and safety bush

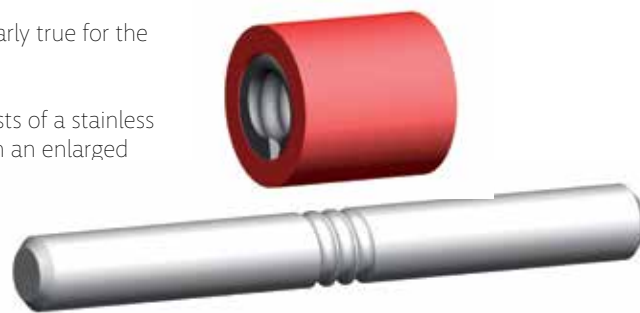
Because safety comes first.


Any whole is more than the sum of its parts – and this is particularly true for the high-quality combinations within the pewag portfolio.

The CBHWI safety set that goes with the Connex connector consists of a stainless steel suspension bolt and a spiral spring (Mat. 1.4571) that is set in an enlarged synthetic sleeve for particularly easy fitting, ensuring that the suspension bolt always locks perfectly in place.

Variety of use: CBHWI bolts and safety bushes for grade 6 correspond to the design of CBHWI grade 5 and may therefore also be used as replacement parts. Please note the modified material properties of grade 6!

Important: The replacement sets for grade 5 are not suitable for CWI grade 6 plus! Only bolts stamped with G6 plus may be used as replacement parts!




| CBHWI Bolts and safety bush   | Code       | For connecting link |
|---|------------|---------------------|
|  | CBHWI 5-6  | CWI 5-6             |
|   | CBHWI 7-6  | CWI 7-6             |
|   | CBHWI 10-6 | CWI 10-6            |
|   | CBHWI 13-6 | CWI 13-6            |
|   | CBHWI 16-6 | CWI 16-6            |

## SFGWI Safety Catch

Extra strength you can count on.

It's all in the name: Safety is what this stainless steel safety catch set with an extra-strong spring and rivetable safety pin is all about. The catch is simple to use and its quality speaks for itself, with even the tiniest parts manufactured to absolute perfection.



| SFGWI Safety catch  | Code        | For hook                        |
|---|-------------|---------------------------------|
|  | SFGWI 5     | HSWI 5 stamped HSK 5 or HK 5    |
|   | SFGWI 7     | HSWI 7 stamped HSK 7 or HK 7    |
|   | SFGWI 10    | HSWI 10 stamped HSK 10 or HK 10 |
|   | SFGWI 13    | HSWI 13 stamped HSK 13 or HK 13 |
|   | SFGWI 16    | HSWI 16 stamped HSK 16 or HK 16 |
|   | SFGWI 5/6-6 | HSWI 5/6 stamped HSWI 5/6       |
|   | SFGWI 7/8-6 | HSWI 7/8 stamped HSWI 7/8       |
|   | SFGWI 10-6  | HSWI 10 stamped HSWI 10         |
|   | SFGWI 13-6  | HSWI 13 stamped HSWI 13         |
|   | SFGWI 16-6  | HSWI 16 stamped HSWI 16         |







## Rectangular Identification Tags

New look.

pewag always remains focused on continuously improving its products wherever possible. For this reason, our lifting identification tags now come in a rectangular shape that offers several benefits, all leading towards greater safety.

The tags are made from corrosion-resistant material and are attached to the sling with a quick-release fastener, also corrosion-resistant, thus significantly improving safety for the user. The idea was to eliminate the errors that were made repeatedly in the past, when users took the number of corners of the identification tag and the chain dimensions to work out the maximum load capacity without taking the markings on the identification tag into consideration. This is due to the fact that in all standard documentation for lifting chains, the number of corners featured by the identification tag corresponds to the grade category of the lifting chain. However, standards only ever describe the minimum requirements of a product and may of course be exceeded.

A rectangular identification tag effectively prevents these sort of errors from occurring and offers users the following benefits:




- Prevents misjudging the carrying capacity of the lifting chain as the user is forced to look at the tag prior to each lifting process
- When the marking is not observed, the lifting chain will be classed as a maximum grade 4
- Corrosion-resistant; therefore resistant to acids, caustics and their vapours
- Easily replaceable due to the corrosion-resistant cable with quick-release fastener
- All information is engraved, allowing for customer-specific markings
- Pre-stamped year dates for periodic inspections make the date of the last inspection immediately apparent
- For periodic inspections, only the month needs to be stamped



## ID Identification Tag

Fully customisable.

Quality should never have to remain anonymous. This stainless steel ID tag set, consisting of a TKWI identification set and a mounting rope, is now fully customisable to feature the customer name or any other logo you would like. Inspection data may also be entered, and a plaque for different grade classifications makes things easier for fitters!

| ID Identification tag   | Code               | For lifting chains      | Consisting of  |
|---|--------------------|-------------------------|--|
|    | ID-Tag set neutral | I- and multi-leg slings | Tag neutral + cable with quick release fastener + safety information |

\* Front side  
\*\* Back side

## Assembled System





pewag winner inox stainless steel chain slings in the assembled system – boundless possibilities for combinations.

1) WLL Reduction WOX 16 – SSWI 5 t-S:

On request also stronger shackles available.

| I-leg chain | II-leg chain |        | III+IV-leg chain |        |
|-------------|--------------|--------|------------------|--------|
| –           | 0-45°        | 45-60° | 0-45°            | 45-60° |
| 5,000       | 7,100        | 5,000  | 10,000           | 7,500  |

Below, you will find an overview of different combinations of components within the assembled system. The possibilities are nearly endless! Of course, there are many more options available. We are also happy to supply customised versions upon request. The pewag customer service team is here to help!

|   | Diameter d [mm] | WLL I-leg [kg] | WLL 0-45° [kg] | WLL 45-60° [kg] | *Top fitting    |                     | **Possible end fittings |                     |              |                      |
|---|-----------------|----------------|----------------|-----------------|-----------------|---------------------|-------------------------|---------------------|--------------|----------------------|
|   |                 |                |                |                 | Master link AWI | Eye sling hook HSWI | Master link AWI         | Transition link BWI | Shackle SSWI | Chain shortener VLWI |
| <b>I-leg chain sling</b>  |                 |                |                |                 |                 |                     |                         |                     |              |                      |
|    | 5               | 630            | -              | -               | AWI 10-6        | HSWI 5/6-6          | AWI 10-6                | BWI 7-6             | SSWI 1.25t-S | VLWI 5/6-6           |
|   | 7               | 1,250          | -              | -               | AWI 13-6        | HSWI 7/8-6          | AWI 13-6                | BWI 9-6             | SSWI 1.25t-S | VLWI 7/8-6           |
|   | 10              | 2,500          | -              | -               | AWI 16-6        | HSWI 10-6           | AWI 16-6                | BWI 13-6            | SSWI 3.2t-S  | VLWI 10-6            |
|   | 13              | 4,250          | -              | -               | AWI 22-6        | HSWI 13-6           | AWI 22-6                | BWI 16-6            | SSWI 5t-S    | VLWI 13-6            |
|   | 16              | 6,300          | -              | -               | AWI 22-6        | HSWI 16-6           | AWI 22-6                | BWI 20-6            | SSWI 5t-S 1) | VLWI 16-6            |
| <b>II-leg chain sling</b>   |                 |                |                |                 |                 |                     |                         |                     |              |                      |
|   | 5               | -              | 850            | 630             | AWI 10-6        | HSWI 5/6-6          | AWI 10-6                | BWI 7-6             | SSWI 1.25t-S | VLWI 5/6-6           |
|   | 7               | -              | 1,750          | 1,250           | AWI 16-6        | HSWI 7/8-6          | AWI 13-6                | BWI 9-6             | SSWI 1.25t-S | VLWI 7/8-6           |
|   | 10              | -              | 3,500          | 2,500           | AWI 18-6        | HSWI 10-6           | AWI 16-6                | BWI 13-6            | SSWI 3.2t-S  | VLWI 10-6            |
|   | 13              | -              | 5,950          | 4,250           | AWI 22-6        | HSWI 13-6           | AWI 22-6                | BWI 16-6            | SSWI 5t-S    | VLWI 13-6            |
|   | 16              | -              | 8,800          | 6,300           | AWI 26-6        | HSWI 16-6           | AWI 22-6                | BWI 20-6            | SSWI 5t-S 1) | VLWI 16-6            |
| <b>III-leg chain sling</b>  |                 |                |                |                 |                 |                     |                         |                     |              |                      |
|  | 5               | -              | 1,300          | 940             | AWI 13-6        | HSWI 5/6-6          | AWI 10-6                | BWI 7-6             | SSWI 1.25t-S | VLWI 5/6-6           |
|   | 7               | -              | 2,600          | 1,850           | AWI 16-6        | HSWI 7/8-6          | AWI 13-6                | BWI 9-6             | SSWI 1.25t-S | VLWI 7/8-6           |
|   | 10              | -              | 5,250          | 3,750           | AWI 22-6        | HSWI 10-6           | AWI 16-6                | BWI 13-6            | SSWI 3.2t-S  | VLWI 10-6            |
|   | 13              | -              | 8,900          | 6,350           | AWI 26-6        | HSWI 13-6           | AWI 22-6                | BWI 16-6            | SSWI 5t-S    | VLWI 13-6            |
|   | 16              | -              | 13,200         | 9,400           | AWI 32-6        | HSWI 16-6           | AWI 22-6                | BWI 20-6            | SSWI 5t-S 1) | VLWI 16-6            |
| <b>IV-leg chain sling</b>   |                 |                |                |                 |                 |                     |                         |                     |              |                      |
|  | 5               | -              | 1,300          | 940             | AWI 13-6        | HSWI 5/6-6          | AWI 10-6                | BWI 7-6             | SSWI 1.25t-S | VLWI 5/6-6           |
|   | 7               | -              | 2,600          | 1,850           | AWI 16-6        | HSWI 7/8-6          | AWI 13-6                | BWI 9-6             | SSWI 1.25t-S | VLWI 7/8-6           |
|   | 10              | -              | 5,250          | 3,750           | AWI 22-6        | HSWI 10-6           | AWI 16-6                | BWI 13-6            | SSWI 3.2t-S  | VLWI 10-6            |
|   | 13              | -              | 8,900          | 6,350           | AWI 26-6        | HSWI 13-6           | AWI 22-6                | BWI 16-6            | SSWI 5t-S    | VLWI 13-6            |
|   | 16              | -              | 13,200         | 9,400           | AWI 32-6        | HSWI 16-6           | AWI 22-6                | BWI 20-6            | SSWI 5t-S 1) | VLWI 16-6            |

L = Effective working length according customer specification

### Application instructions for shortening



Correct application



Correct application



Correct application



Wrong application



## PCWI Stainless Steel Pump Chains

All round power packs.

These high-grade pump chains have a load capacity that ranges from 200 to max. 12,000 kg. Their welded design, solid construction and range of components makes them particularly suitable for submersible pumps and breathers in water and wastewater applications.

### Systematic expediency

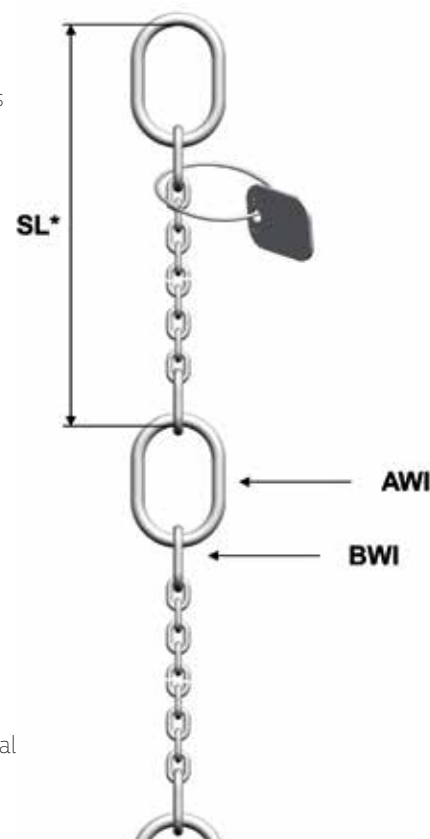
These pump chains are tested for perfection and serialised with a dedicated identification tag and test certificate, issued individually for each chain. Enlarged master links at the beginning, at segmented intervals and at the end of the chain make them ideally suited for step-by-step lowering, lifting or locking.

Upon request, we also offer customised variations:

- Two-legged system with "Y" for pumps equipped with 2 eye screws
- Alternative end fittings, such as eye hooks, BWI links or shackles
- Additional stabilisation chain
- Variation of standard segment length
- Customised models available
- Stainless steel hoist chains for pump stations are available upon request

We recommend safety shackles type SSWI for joining the pump to the chain.

When placing an order, please indicate the desired total length of the chain or the number of segments as well as the end fitting (e.g. AWI Master link). Note: The actual length is a multiple of the segment length, plus the length of the end fitting!



| Type [mm]  | WLL [kg] | Master link | Dimensions AWI [mm] | Transition link | Dimensions BWI [mm] | Chain type | SL* Number of links | Segment length SL* [mm] | Length of master links/end links [mm] | Weight SL* [kg] |
|------------|----------|-------------|---------------------|-----------------|---------------------|------------|---------------------|-------------------------|---------------------------------------|-----------------|
| PCWI 4/200 | 200      | AWI 6       | 6x60x35             |                 |                     | WOX 4x12   | 77                  | 984                     | 60                                    | 0.39            |
| PCWI 4/400 | 400      | AWI 8       | 8x60x35             | BWI 5           | 5x26x13             | WOX 4x12   | 73                  | 988                     | 60                                    | 0.43            |
| PCWI 5/560 | 560      | AWI 8       | 8x60x35             | BWI 7           | 7x36x16             | WOX 5x15   | 53                  | 943                     | 60                                    | 0.62            |
| PCWI 5/630 | 630      | AWI 10      | 10x80x50            | BWI 7           | 7x36x16             | WOX 5x15   | 53                  | 963                     | 80                                    | 0.68            |
| PCWI 6     | 850      | AWI 10      | 10x80x50            | BWI 7           | 7x36x16             | WOX 6x18   | 47                  | 998                     | 80                                    | 0.90            |
| PCWI 7     | 1,250    | AWI 13      | 13x110x60           | BWI 9           | 9x44x20             | WOX 7x21   | 37                  | 975                     | 110                                   | 1.35            |
| PCWI 8     | 1,600    | AWI 13      | 13x110x60           | BWI 10          | 10x44x20            | WOX 8x24   | 33                  | 990                     | 110                                   | 1.70            |
| PCWI 10    | 2,500    | AWI 16      | 16x110x60           | BWI 13          | 13x54x25            | WOX 10x30  | 25                  | 968                     | 110                                   | 2.6             |
| PCWI 13    | 3,500    | AWI 18      | 18x135x75           | BWI 16          | 17x70x34            | WOX 13x39  | 19                  | 1,016                   | 160                                   | 4.50            |
| PCWI 16    | 6,300    | AWI 22      | 23x160x90           | BWI 20          | 20x85x40            | WOX 16x48  | 15                  | 1,050                   | 135                                   | 8.00            |
| PCWI 20**  | 8,000    | AWI 26      | 27x180x100          | BWI 22          | 23x115x50           | WOX 20x60  | 27                  | 2,030                   | 180                                   | 21              |
| PCWI 26**  | 12,000   | AWI 45      | 45x340x180          | BWI 32          | 32x150x70           | WOX 26x78  | 19                  | 2,122                   | 340                                   | 43.20           |

\* SL consisting of 1 x AWI, 2 x BWI, WOX chain in standard length. PCWI 4/200 manufactured without transition links BWI.  
\*\* Made to order.



## Welded System

Perfection, piece by piece: pewag winner inox stainless steel chain slings and endless chains in the welded system.

1) WLL Reduction WOX 16 – SSWI 5 t-S:

On request also stronger shackles available.

| I-leg chain | II-leg chain | III+IV-leg chain |
|-------------|--------------|------------------|
| -           | 0-45°        | 45-60°           |
| 5,000       | 7,100        | 5,000            |
|             |              | 10,000           |
|             |              | 7,500            |

Below, you will find an overview of different combinations of stainless steel chain slings and components as well as endless chains. Of course, there are many more options available. We are also glad to supply customised variations upon request. The pewag customer service team is here to help!

| Diameter d [mm]            | WLL I-leg [kg] | WLL 0-45° [kg] | WLL 45-60° [kg] | *Top fitting    |                     | **Possible end fittings |                     |              |                      |            |
|----------------------------|----------------|----------------|-----------------|-----------------|---------------------|-------------------------|---------------------|--------------|----------------------|------------|
|                            |                |                |                 | Master link AWI | Eye sling hook HSWI | Master link AWI         | Transition link BWI | Shackle SSWI | Chain shortener VLWI |            |
|                            |                |                |                 |                 |                     |                         |                     |              |                      |            |
| <b>I-leg chain sling</b>   |                |                |                 |                 |                     |                         |                     |              |                      |            |
|                            | 4              | 400            | -               | -               | AWI 8-6             | -                       | AWI 8-6             | BWI 5-6      | SSWI 0.5t-S          | -          |
|                            | 5              | 630            | -               | -               | AWI 10-6            | HSWI 5/6-6              | AWI 10-6            | BWI 7-6      | SSWI 1.25t-S         | VLWI 5/6-6 |
|                            | 6              | 900            | -               | -               | AWI 13-6            | HSWI 5/6-6              | AWI 13-6            | BWI 7-6      | SSWI 1.25t-S         | VLWI 5/6-6 |
|                            | 7              | 1,250          | -               | -               | AWI 13-6            | HSWI 7/8-6              | AWI 13-6            | BWI 9-6      | SSWI 1.25t-S         | VLWI 7/8-6 |
|                            | 8              | 1,600          | -               | -               | AWI 13-6            | HSWI 7/8-6              | AWI 13-6            | BWI 10-6     | SSWI 2t-S            | VLWI 7/8-6 |
|                            | 10             | 2,500          | -               | -               | AWI 16-6            | HSWI 10-6               | AWI 16-6            | BWI 13-6     | SSWI 3.2t-S          | VLWI 10-6  |
|                            | 13             | 4,250          | -               | -               | AWI 22-6            | HSWI 13-6               | AWI 22-6            | BWI 16-6     | SSWI 5t-S            | VLWI 13-6  |
|                            | 16             | 6,300          | -               | -               | AWI 22-6            | HSWI 16-6               | AWI 22-6            | BWI 20-6     | SSWI 5t-S 1)         | VLWI 16-6  |
|                            | 20             | 8,000          | -               | -               | AWI 26-6            | -                       | AWI 26-6            | BWI 26-6     | SSWI 26-C            | -          |
|                            | 26             | 12,000         | -               | -               | AWI 45-6            | -                       | AWI 45-6            | BWI 32-6     | SSWI 26-C            | -          |
| <b>II-leg chain sling</b>  |                |                |                 |                 |                     |                         |                     |              |                      |            |
|                            | 4              | -              | 560             | 400             | AWI 8-6             | -                       | AWI 8-6             | BWI 5-6      | SSWI 0.5t-S          | -          |
|                            | 5              | -              | 850             | 630             | AWI 10-6            | HSWI 5/6-6              | AWI 10-6            | BWI 7-6      | SSWI 1.25t-S         | VLWI 5/6-6 |
|                            | 6              | -              | 1,250           | 900             | AWI 13-6            | HSWI 5/6-6              | AWI 13-6            | BWI 7-6      | SSWI 1.25t-S         | VLWI 5/6-6 |
|                            | 7              | -              | 1,750           | 1,250           | AWI 16-6            | HSWI 7/8-6              | AWI 13-6            | BWI 9-6      | SSWI 1.25t-S         | VLWI 7/8-6 |
|                            | 8              | -              | 2,200           | 1,600           | AWI 16-6            | HSWI 7/8-6              | AWI 13-6            | BWI 10-6     | SSWI 2t-S            | VLWI 7/8-6 |
|                            | 10             | -              | 3,500           | 2,500           | AWI 18-6            | HSWI 10-6               | AWI 16-6            | BWI 13-6     | SSWI 3.2t-S          | VLWI 10-6  |
|                            | 13             | -              | 5,950           | 4,250           | AWI 22-6            | HSWI 13-6               | AWI 22-6            | BWI 16-6     | SSWI 5t-S            | VLWI 13-6  |
|                            | 16             | -              | 8,800           | 6,300           | AWI 26-6            | HSWI 16-6               | AWI 22-6            | BWI 20-6     | SSWI 5t-S 1)         | VLWI 16-6  |
|                            | 20             | -              | 11,200          | 8,000           | AWI 32-6            | -                       | AWI 26-6            | BWI 26-6     | SSWI 26-C            | -          |
| <b>III-leg chain sling</b> |                |                |                 |                 |                     |                         |                     |              |                      |            |
|                            | 4              | -              | 840             | 600             | VWI 4-6             | -                       | AWI 8-6             | BWI 5-6      | SSWI 0.5t-S          | -          |
|                            | 5              | -              | 1,300           | 940             | VWI 5/6-6           | HSWI 5/6-6              | AWI 10-6            | BWI 7-6      | SSWI 1.25t-S         | VLWI 5/6-6 |
|                            | 6              | -              | 1,850           | 1,350           | VWI 5/6-6           | HSWI 5/6-6              | AWI 13-6            | BWI 7-6      | SSWI 1.25t-S         | VLWI 5/6-6 |
|                            | 7              | -              | 2,600           | 1,850           | VWI 5/6-6           | HSWI 7/8-6              | AWI 13-6            | BWI 9-6      | SSWI 1.25t-S         | VLWI 7/8-6 |
|                            | 8              | -              | 3,350           | 2,400           | VWI 8-6             | HSWI 7/8-6              | AWI 13-6            | BWI 10-6     | SSWI 2t-S            | VLWI 7/8-6 |
|                            | 10             | -              | 5,250           | 3,750           | VWI 10-6            | HSWI 10-6               | AWI 16-6            | BWI 13-6     | SSWI 3.2t-S          | VLWI 10-6  |
|                            | 13             | -              | 8,900           | 6,350           | VWI 13-6            | HSWI 13-6               | AWI 22-6            | BWI 16-6     | SSWI 5t-S            | VLWI 13-6  |
|                            | 16             | -              | 13,200          | 9,400           | VWI 16-6            | HSWI 16-6               | AWI 22-6            | BWI 20-6     | SSWI 5t-S 1)         | VLWI 16-6  |
| <b>IV-leg chain sling</b>  |                |                |                 |                 |                     |                         |                     |              |                      |            |
|                            | 4              | -              | 840             | 600             | VWI 4-6             | -                       | AWI 8-6             | BWI 5-6      | SSWI 0.5t-S          | -          |
|                            | 5              | -              | 1,300           | 940             | VWI 5/6-6           | HSWI 5/6-6              | AWI 10-6            | BWI 7-6      | SSWI 1.25t-S         | VLWI 5/6-6 |
|                            | 6              | -              | 1,850           | 1,350           | VWI 5/6-6           | HSWI 5/6-6              | AWI 13-6            | BWI 7-6      | SSWI 1.25t-S         | VLWI 5/6-6 |
|                            | 7              | -              | 2,600           | 1,850           | VWI 5/6-6           | HSWI 7/8-6              | AWI 13-6            | BWI 9-6      | SSWI 1.25t-S         | VLWI 7/8-6 |
|                            | 8              | -              | 3,350           | 2,400           | VWI 8-6             | HSWI 7/8-6              | AWI 13-6            | BWI 10-6     | SSWI 2t-S            | VLWI 7/8-6 |
|                            | 10             | -              | 5,250           | 3,750           | VWI 10-6            | HSWI 10-6               | AWI 16-6            | BWI 13-6     | SSWI 3.2t-S          | VLWI 10-6  |
|                            | 13             | -              | 8,900           | 6,350           | VWI 13-6            | HSWI 13-6               | AWI 22-6            | BWI 16-6     | SSWI 5t-S            | VLWI 13-6  |
|                            | 16             | -              | 13,200          | 9,400           | VWI 16-6            | HSWI 16-6               | AWI 22-6            | BWI 20-6     | SSWI 5t-S 1)         | VLWI 16-6  |

L = Effective working length according customer specification





---

Shackles

75



## Feel Confident in Every Situation

Our lifting systems are valued for their long durability and high quality. Whether the working environment is hot or cold, our systems assure lifting operations with high safety and functionality.

Gunnebo Lifting shackles are made from a range of steel qualities, including acid proof stainless steel and high grade alloy steel to comply with the most stringent specifications. Our workshops comprise all facilities and systems for the manufacturing and control of a top quality product. This includes tool design, an advanced tool shop, forging, heat treatment, machining, hot dip galvanizing and quality control.

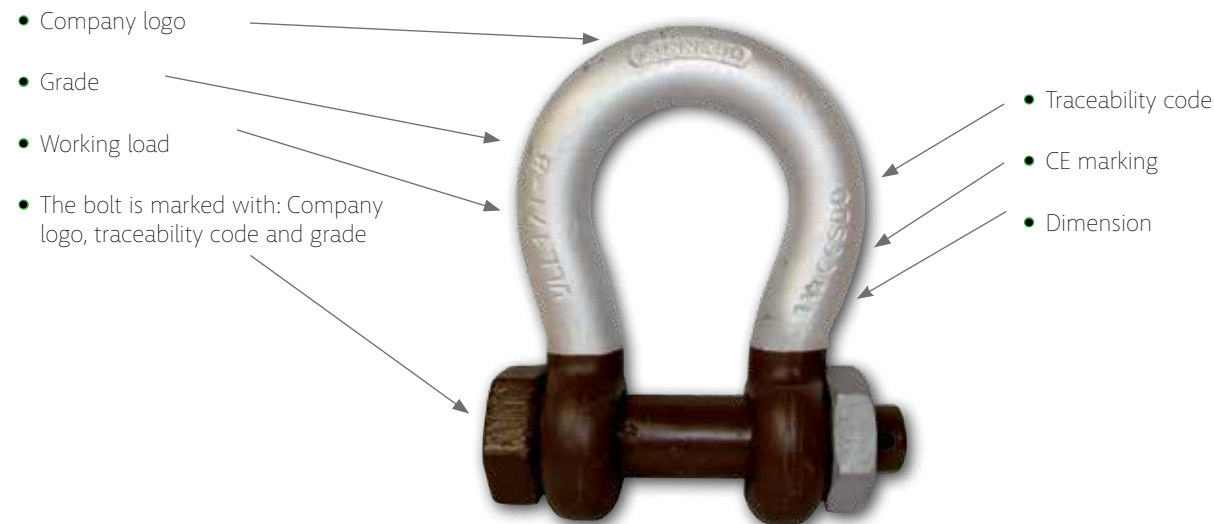
We offer a range of DNV 2.7-1 Type approved lifting shackles of offshore for containers, developed for the tough conditions of the offshore industry, where safety must be of highest priority at all times. The heat treatment of these products ensures the proper ductility and strength to sustain shock loads which may be imposed when the container is lifted from the deck of a vessel.

Furthermore we offer Standard shackles, Super lifting shackles with increased working load limit, ROV shackles, Heavy duty shackles, Wide-Body shackles, Mooring shackles, Stainless Steel shackles etc.

## Make sure you have the original

- High quality shackles acc. EN 13889 and U.S. Fed.Spec RR-C. 271 (grade A and grade B)
- Consistent product quality
- Long experience of shackle production using modern manufacturing methods
- Local availability expertise from Gunnebo Lifting subsidiary or distributors

To ensure you have a genuine Gunnebo Lifting Shackle, it should be marked as below:



## Product documentation

Upon request at time of order, load rated products can be supplied with:

- Works certificate acc. EN 10204 - 2.1
- Sample certificate of raw material acc. EN 10204 - 3.1
- Test certificate
- Traceable rawmaterial / inspection certificate acc. EN 10204 - 3.1
- Third part proof load documentation



## Gunnebo Lifting Standard Shackle No 834 and No 835

### Dee shackles

Standard: DNV 2.7-1 Type-Approved, EN-13889 and U.S Fed. Spec. RR-C-271

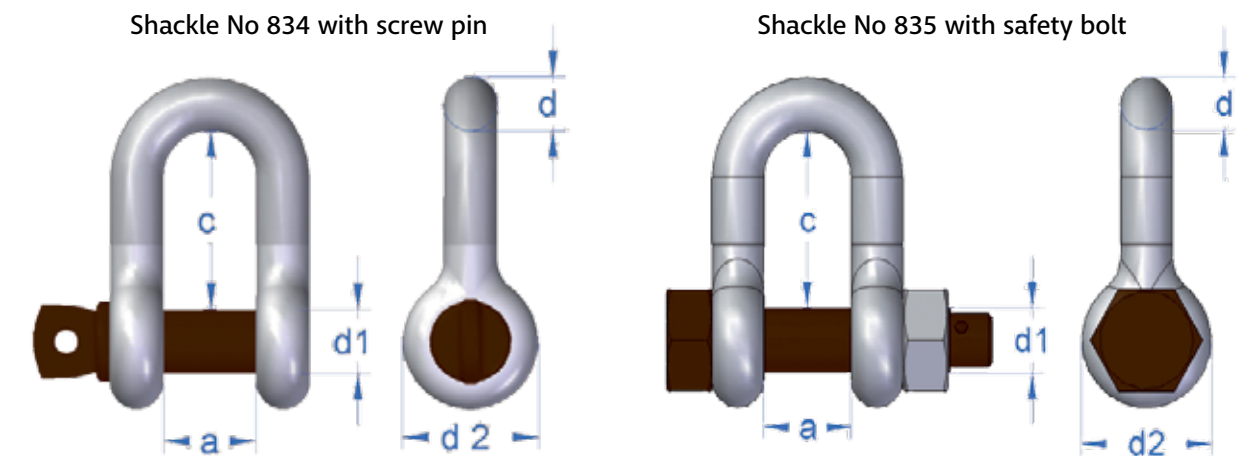
Material: High Tensile Carbon Steel, Quenched and tempered, Grade 6

Finish: All parts hot dip galvanized, brown painted pins on top of galv.

Safety factor: 6:1

Documentation: Test certificate and traceable raw material / inspection certificate acc. EN 10204 - 3.1  
Sizes from 2 - 25 tonnes can be supplied with DNV 2.7-1 Type Approval Certification.

Temperature: -20°C to 200°C



Measurement in mm

| Art. no. Screw pin | Art. no. Safety bolt | Dim. d1 | Dim. d (mm - inch) | Inner width a* | Inner length c* | Eye outer d2 | WLL (tonnes) 6:1 | Screw pin (kgs) | Safety bolt (kgs) |
|--------------------|----------------------|---------|--------------------|----------------|-----------------|--------------|------------------|-----------------|-------------------|
| A083405            | -                    | 6       | 5 - 3/16"          | 10             | 22              | 13           | 0.33             | 0.02            | -                 |
| A083406            | -                    | 8       | 7 - 1/4"           | 12             | 25              | 12           | 0.5              | 0.06            | -                 |
| A083408            | -                    | 10      | 9 - 5/16"          | 13.5           | 27              | 16           | 0.75             | 0.11            | -                 |
| A083409            | -                    | 11      | 10 - 3/8"          | 17             | 31              | 20           | 1                | 0.15            | -                 |
| A083411            | -                    | 13      | 11 - 7/16"         | 18.5           | 37              | 22           | 1.5              | 0.21            | -                 |
| A083413            | A083513              | 16      | 13 - 1/2"          | 21             | 41              | 33           | 2                | 0.25            | 0.30              |
| A083416            | A083516              | 19      | 16 - 5/8"          | 27             | 51              | 40           | 3.25             | 0.55            | 0.60              |
| A083419            | A083519              | 22      | 19 - 3/4"          | 31             | 60              | 47           | 4.75             | 1.00            | 1.10              |
| A083422            | A083522              | 25      | 22 - 7/8"          | 37             | 71              | 50           | 6.5              | 1.30            | 1.50              |
| A083425            | A083525              | 28      | 25 - 1"            | 43             | 81              | 58           | 8.5              | 1.90            | 2.20              |
| A083428            | A083528              | 32      | 28 - 1.1/8"        | 46             | 90              | 64           | 9.5              | 2.80            | 3.10              |
| A083432            | A083532              | 35      | 32 - 1.1/4"        | 52             | 100             | 72           | 12               | 3.60            | 4.20              |
| A083435            | A083535              | 38      | 35 - 1.3/8"        | 57             | 111             | 74           | 13.5             | 4.60            | 5.60              |
| A083438            | A083538              | 42      | 38 - 1.1/2"        | 60             | 122             | 84           | 17               | 6.50            | 7.50              |
| A083445            | A083545              | 50      | 45 - 1.3/4"        | 74             | 149             | 105          | 25               | 11.50           | 13.00             |
| A083452            | A083552              | 57      | 50 - 2"            | 83             | 171             | 127          | 35               | 16.00           | 18.00             |
| -                  | A083564              | 70      | 65 - 2.1/2"        | 105            | 203             | 152          | 55               | -               | 39.00             |

\* Forging tolerance: +/- 5% on inside width/length.

## Standard Shackle No 854 and No 855

### Bow shackles

Standard: DNV 2.7-1 Type-Approved, EN-13889 and U.S Fed. Spec. RR-C-271

Material: High Tensile Carbon Steel, Quenched and tempered, Grade 6

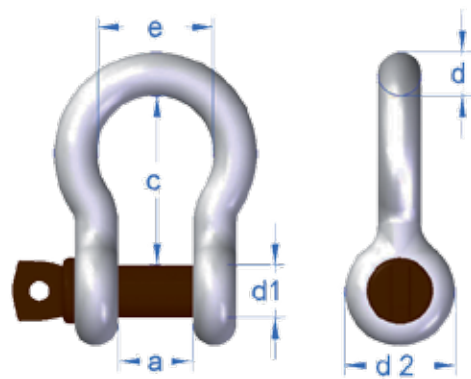
Finish: All parts hot dip galvanized, brown painted pins on top of galv.

Safety factor: 6:1

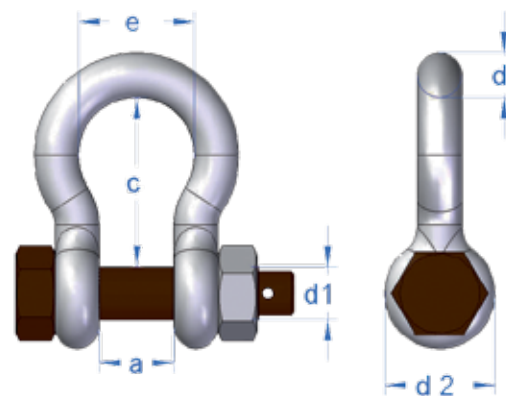
Documentation: Test certificate and traceable raw material / inspection certificate acc. EN-10204 - 3.1.  
Sizes from 2 - 25 tonnes can be supplied with DNV 2.7-1 Type Approval Certification.

Temperature: -20°C to 200°C

Shackle No 854 with screw pin



Shackle No 855 with safety bolt



Measurement (mm)

| Art. no.<br>Screw pin | Art. no.<br>Safety bolt | Dim.<br>d1 | Dim.<br>d<br>(mm - inch) | inner<br>width<br>a* | inner<br>length<br>c* | Bow<br>width<br>e | Eye<br>outer<br>d2 | WLL<br>(tonnes)<br>6:1 | Screw pin<br>(kgs) | Safety bolt<br>(kgs) |
|-----------------------|-------------------------|------------|--------------------------|----------------------|-----------------------|-------------------|--------------------|------------------------|--------------------|----------------------|
| A085405               | -                       | 6          | 5 - 3/16"                | 10                   | 22                    | 16                | 13                 | 0.33                   | 0.02               | -                    |
| A085406               | A085506                 | 8          | 6 - 1/4"                 | 12                   | 29                    | 20                | 16                 | 0.5                    | 0.06               | 0.07                 |
| A085408               | A085508                 | 10         | 8 - 5/16"                | 13                   | 32                    | 21                | 20                 | 0.75                   | 0.11               | 0.13                 |
| A08409                | A085509                 | 11         | 9 - 3/8"                 | 16                   | 36                    | 26                | 22                 | 1                      | 0.15               | 0.17                 |
| A085411               | A085511                 | 13         | 11 - 7/16"               | 18                   | 43                    | 29                | 26                 | 1.5                    | 0.21               | 0.25                 |
| A085413               | A085513                 | 16         | 13 - 1/2"                | 21                   | 47                    | 33                | 33                 | 2                      | 0.37               | 0.42                 |
| A085416               | A085516                 | 19         | 16 - 5/8"                | 27                   | 60                    | 42                | 40                 | 3.25                   | 0.65               | 0.70                 |
| A085419               | A085519                 | 22         | 19 - 3/4"                | 31                   | 71                    | 51                | 47                 | 4.75                   | 1.10               | 1.20                 |
| A085422               | A085522                 | 25         | 22 - 7/8"                | 37                   | 84                    | 58                | 50                 | 6.5                    | 1.50               | 1.70                 |
| A085425               | A085525                 | 28         | 25 - 1"                  | 43                   | 95                    | 68                | 58                 | 8.5                    | 2.20               | 2.50                 |
| A085428               | A085528                 | 32         | 28 - 1.1/8"              | 46                   | 108                   | 74                | 64                 | 9.5                    | 3.10               | 3.40                 |
| A085432               | A085532                 | 35         | 32 - 1.1/4"              | 52                   | 119                   | 83                | 72                 | 12                     | 4.20               | 4.80                 |
| A08545                | A085535                 | 38         | 35 - 1.3/8"              | 57                   | 132                   | 89                | 74                 | 13.5                   | 6.00               | 7.00                 |
| A085438               | A085538                 | 42         | 38 - 1.1/2"              | 60                   | 146                   | 98                | 84                 | 17                     | 8.00               | 9.00                 |
| A085445               | A085545                 | 50         | 45 - 1.3/4"              | 74                   | 178                   | 127               | 105                | 25                     | 13.50              | 15.00                |
| A085452               | A085552                 | 57         | 50 - 2"                  | 83                   | 197                   | 138               | 127                | 35                     | 19.00              | 21.00                |
| -                     | A085556                 | 65         | 57 - 2.1/4"              | 95                   | 222                   | 160               | 140                | 42.5                   | -                  | 28.50                |
| A085464               | A085564                 | 70         | 65 - 2.1/2"              | 105                  | 255                   | 185               | 152                | 55                     | 38.00              | 39.00                |
| -                     | A085576                 | 83         | 75 - 3"                  | 127                  | 330                   | 190               | 165                | 85                     | -                  | 62.00                |
| -                     | **A085589               | 95         | 89 - 3.1/2"              | 146                  | 380                   | 235               | 203                | 120 (5:1)              | -                  | 110.00               |

\* Forging tolerance: +/- 5% on inside width/length.

\*\* Safety factor 5:1

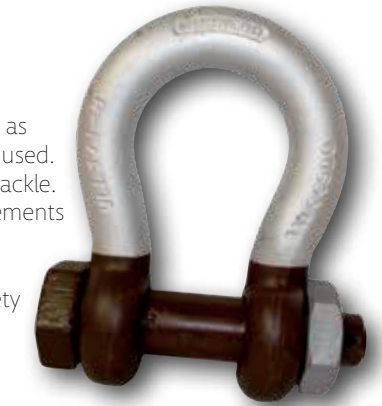
## Arctic Shackle No 856

### Bow shackle with safety bolt

#### Unique Benefits with The Arctic Shackle

Adverse weather and rough sea conditions in combination with extremely low temperatures, as often encountered in the North Sea for instance, places tough requirements on the products used. Gunnebo Lifting has a range of shackles specially designed for these conditions: The Arctic Shackle. This shackle is type approved to DnV 2.7-1 Offshore containers and meets the impact requirements of 42 J at - 40 degrees oC.

The Arctic Shackle is a grade 8 shackle with all parts hot dipped galvanized, including the safety pin, and has the characteristic brown colour marking.



Standard: DNV 2.7-1, U.S. Fed. Spec. RR.C-271 and EN-13889

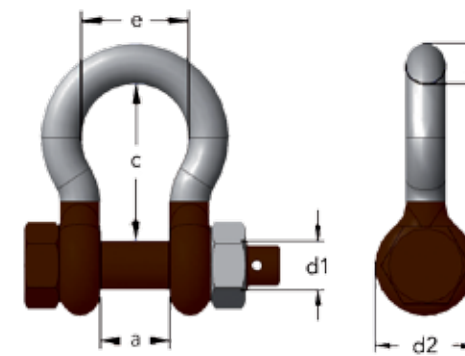
Material: Special Alloy Steel, Quenched and Tempered, Grade 8

Finish: All parts hot dip galvanized + brown colour marking

Safety factor: As specified in the table below

Documentation: Test certificate and traceable raw material / inspection certificate acc. EN-10204 - 3.1 All sizes can be supplied with DNV 2.7-1 Type Approval Certification.

Temperature: - 40 °C to 200 °C



| Art. no. | d1 | Dim. d<br>(mm - inch) | a   | c   | d 2 | e   | WLL<br>(tonnes) | Weight<br>(kgs) | Safety<br>factor |
|----------|----|-----------------------|-----|-----|-----|-----|-----------------|-----------------|------------------|
| A085613  | 16 | 13 - 1/2"             | 21  | 47  | 33  | 33  | 2               | 0.42            | 8.00             |
| A085616  | 19 | 16 - 5/8"             | 27  | 60  | 40  | 42  | 3.3             | 0.7             | 8.00             |
| A085619  | 22 | 19 - 3/4"             | 31  | 71  | 47  | 51  | 4.8             | 1.2             | 8.00             |
| A085622  | 25 | 22 - 7/8"             | 37  | 84  | 52  | 58  | 6.5             | 1.7             | 7.85             |
| A085625  | 28 | 25 - 1"               | 43  | 95  | 58  | 68  | 8.5             | 2.5             | 7.25             |
| A085628  | 32 | 28 - 1.1/8"           | 46  | 108 | 64  | 74  | 9.5             | 3.4             | 6.94             |
| A085632  | 35 | 32 - 1.1/4"           | 52  | 119 | 72  | 83  | 12              | 4.8             | 6.40             |
| A085635  | 38 | 35 - 1.3/8"           | 57  | 132 | 74  | 89  | 13.5            | 7               | 6.10             |
| A085638  | 42 | 38 - 1.1/2"           | 60  | 146 | 84  | 98  | 17              | 9               | 6.00             |
| A085645  | 50 | 45 - 1.3/4"           | 74  | 178 | 105 | 127 | 25              | 15              | 6.00             |
| A085652  | 57 | 50 - 2"               | 83  | 197 | 119 | 138 | 35              | 21              | 6.00             |
| A085664  | 70 | 65 - 2.1/2"           | 105 | 255 | 145 | 185 | 55              | 39              | 6.00             |
| A085676  | 83 | 75 - 3"               | 127 | 330 | 165 | 190 | 85              | 62              | 6.00             |

## Super Shackle No 858

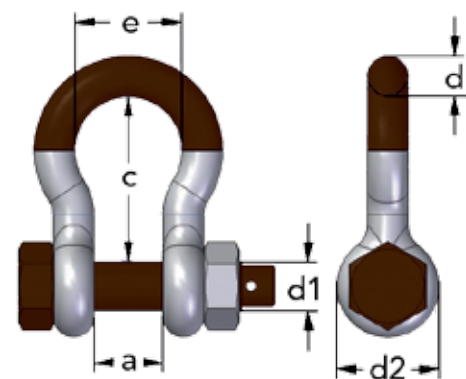
### Bow shackle with safety bolt

#### Unique Benefits with The Super Shackle

In certain situations, a demand for extra Working Load Limit occurs, in others the lifting environment has limited space for the lifting application. Gunnebo Lifting has therefore added the Super Shackle to the range, enabling the same Working Load Limit on a 22 mm Super shackle as for a 28 mm Standard shackle.

The Gunnebo Lifting Super shackle meets the US Federal Specification RR.C-271. It is a grade 8 shackle and has all parts hot dipped galvanized, including the safety pin.

Standard: U.S. Fed. Spec. RR.C-271 Type IVA Class 3, Grade B  
 Material: High Tensile Steel. Quenched and Tempered, Grade 8  
 Finish: All parts hot dip galvanized + brown colour marking  
 Safety factor: 5:1  
 Documentation: Test certificate and traceable 3.1 certificate



Split pin included

| Art.no  | d1 | Dim. d (mm - inch) | a   | c   | d2  | e   | WLL (tonnes) | Weight (kgs) |
|---------|----|--------------------|-----|-----|-----|-----|--------------|--------------|
| A085813 | 16 | 13 - 1/2"          | 21  | 51  | 33  | 33  | 3.3          | 0.4          |
| A085816 | 19 | 16 - 5/8"          | 27  | 60  | 40  | 42  | 5            | 0.7          |
| A085819 | 22 | 19 - 3/4"          | 31  | 71  | 47  | 51  | 7            | 1.2          |
| A085822 | 25 | 22 - 7/8"          | 37  | 84  | 52  | 58  | 9.5          | 1.7          |
| A085825 | 28 | 25 - 1"            | 43  | 95  | 58  | 68  | 12.5         | 2.5          |
| A085828 | 32 | 28 - 1 1/8"        | 46  | 108 | 64  | 74  | 15           | 3.4          |
| A085832 | 35 | 32 - 1 1/4"        | 52  | 119 | 72  | 83  | 18           | 4.8          |
| A085835 | 38 | 35 - 1 3/8"        | 57  | 132 | 74  | 89  | 21           | 7            |
| A085838 | 42 | 38 - 1 1/2"        | 60  | 146 | 89  | 99  | 30           | 8.8          |
| A085845 | 50 | 45 - 1 3/4"        | 74  | 178 | 105 | 126 | 40           | 15           |
| A085857 | 57 | 57 - 2 1/4"        | 83  | 197 | 117 | 138 | 55           | 22           |
| A085870 | 70 | 70 - 2 3/4"        | 105 | 260 | 143 | 180 | 85           | 38           |
| A085883 | 83 | 83 - 3 3/4"        | 127 | 329 | 162 | 190 | 120          | 70           |
| A085895 | 95 | 95 - 3 3/4"        | 144 | 400 | 208 | 238 | 150          | 112          |

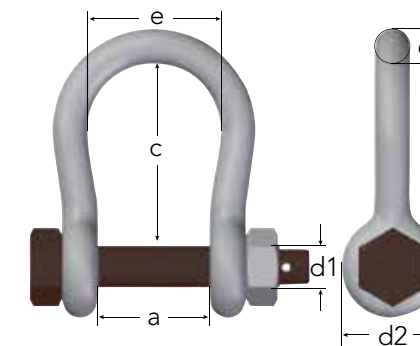
## Fishing and aquaculture

### Mooring Shackle No 852

Standard: Third party approved acc. to relevant Norwegian aquaculture standards

Material: High Tensile Steel. Quenched and Tempered, Grade 6

Finish: All parts hot dip galvanized + brown colour marking



| Art.no  | Dim. d (mm - inch) | MBL (tonnes) | a   | c   | e   | d2  | d1 |
|---------|--------------------|--------------|-----|-----|-----|-----|----|
| A085219 | 19 - 3/4"          | 28           | 44  | 100 | 58  | 47  | 22 |
| A085222 | 22 - 7/8"          | 40           | 52  | 125 | 68  | 50  | 25 |
| A085228 | 28 - 1 1/8"        | 60           | 62  | 150 | 89  | 58  | 28 |
| A085232 | 32 - 1 1/4"        | 90           | 82  | 170 | 98  | 72  | 32 |
| A085245 | 45 - 1 3/4"        | 150          | 126 | 248 | 140 | 105 | 50 |

#### Available Safety Pins

Plastic clip (28T - 40T Yellow / 60-90 Green)

Green seizing wire

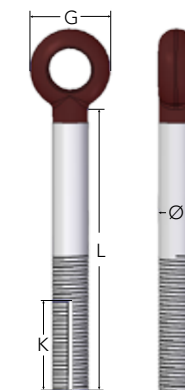
- Steel core with 5-10 mm zinc coat and also PVC coated

Yellow/green seizing wire (dim Ø5,5 mm x 250 mm)

Split pin (dim Ø 5,5 mm x 40 mm)

- Copper core (Ø4,0 mm PVC coated)

- Can be delivered electric plated or acid proof

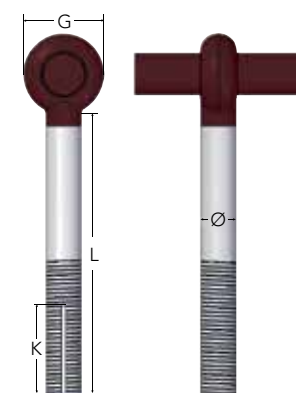


### Gunnebo Lifting Mooring bolts - Eye Bolt no. 8250

Material: High Tensile Steel. Quenched and Tempered, Grade 6

Finish: All parts hot dip galvanized + brown colour marking

| Art.no  | dim Ø x L | MBL  | G   | E  |
|---------|-----------|------|-----|----|
| A825032 | Ø32 x 400 | 40 T | 72  | 38 |
| A825038 | Ø38 x 500 | 60 T | 84  | 46 |
| A825045 | Ø45 x 600 | 80 T | 105 | 54 |



### Gunnebo Lifting Mooring bolts - T-bolt no. 8252

Material: High Tensile Steel. Quenched and Tempered, Grade 6

Finish: All parts hot dip galvanized + brown colour marking

| Art.no  | dim Ø x L | MBL   | G   | E  | L   |
|---------|-----------|-------|-----|----|-----|
| A825232 | Ø32 x 400 | 40 T  | 72  | 35 | 400 |
| A825235 | Ø35 x 400 | 50 T  | 76  | 38 | 400 |
| A825238 | Ø38 x 500 | 60 T  | 84  | 42 | 500 |
| A825245 | Ø45 x 600 | 80 T  | 105 | 45 | 600 |
| A825250 | Ø50 x 700 | 100 T | 110 | 50 | 700 |

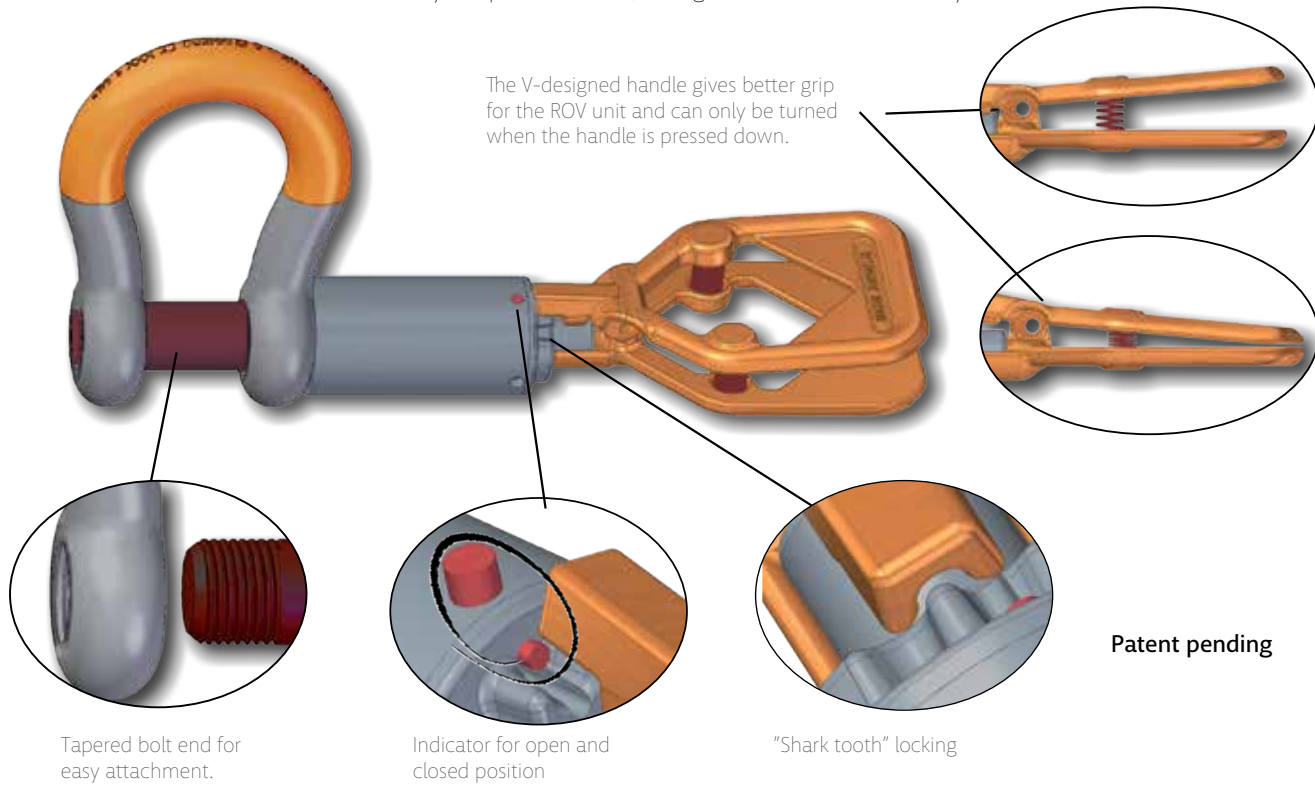


## ROV Shackles

The ROV Retrieve Shackle is designed for smooth and easy use in retrieving and releasing subsea lifting and rigging operations. It has no loose parts, in closed or opened position, and there is therefore no need for wires or monkey fists that will risk snagging or getting in the way.

The high visibility handles are close-die forged and has double safety functions - shark tooth locking with indicator that will show if the shackle is in open or locked position as well as the spring loaded handle. The handle is the same size, regardless of size of shackle.

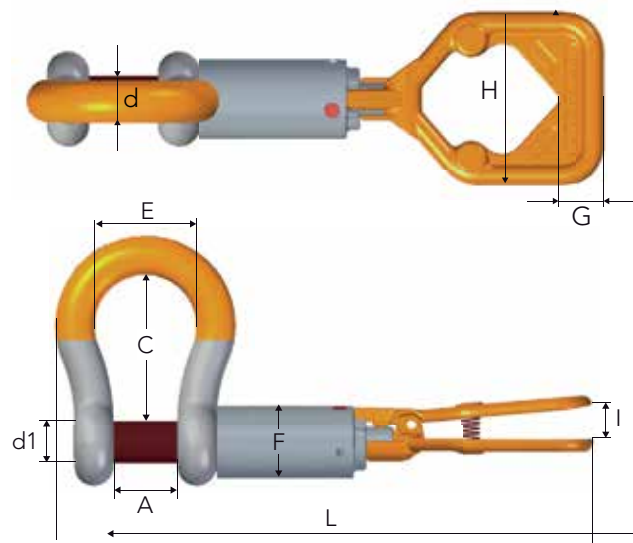
The ROV Retrieve Shackle no. 861 is an easy to operate shackle, saving valuable time and money.



### ROV Retrieve Shackle No 861

All shackles have unique marking

Standard: Dim. according to EN 13889  
 Material: High Tensile Steel, Quenched and Tempered  
 Finish: All load bearing parts hot dip galvanized  
 Safety factor: 6:1  
 Documentation: Test certificate and traceable 3.1 certificate can be supplied on request  
 Impact values: -40 °C to 200 °C, 42 Joule

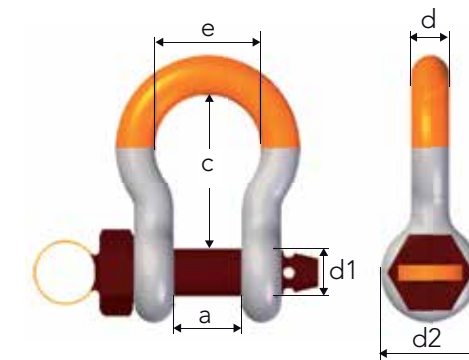


| Art. no | d1 | d  | A   | C   | E   | F    | L   | I  | H   | G  | WLL (tonnes) | Weight (kg) |
|---------|----|----|-----|-----|-----|------|-----|----|-----|----|--------------|-------------|
| A086132 | 35 | 32 | 52  | 119 | 83  | 60   | 460 | 31 | 132 | 33 | 12           | 8.0         |
| A086138 | 42 | 38 | 60  | 146 | 98  | 63.5 | 501 | 31 | 132 | 33 | 17           | 10.5        |
| A086145 | 50 | 45 | 74  | 178 | 127 | 70   | 565 | 31 | 132 | 33 | 25           | 16.5        |
| A086152 | 57 | 50 | 83  | 197 | 138 | 76   | 604 | 31 | 132 | 33 | 35           | 20.5        |
| A086164 | 70 | 65 | 105 | 255 | 185 | 88   | 712 | 31 | 132 | 33 | 55           | 42.0        |

All dimensions in mm

### ROV Shackle no. 860 Threaded bolt with locking pin

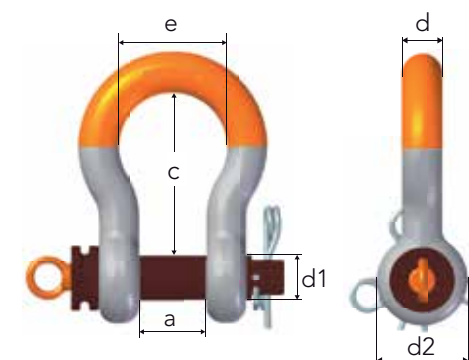
Standard: Dim. according to EN 13889  
 Material: High Tensile Steel, Quenched and Tempered  
 Finish: All load bearing parts hot dip galvanized  
 Safety factor: 6:1  
 Documentation: Test certificate and traceable 3.1 certificate can be supplied on request  
 Temperature: -20 °C to 200 °C



| Art. no. | d1 | d  | a   | c   | d2  | e   | WLL (tonnes) | Weight (kgs) |
|----------|----|----|-----|-----|-----|-----|--------------|--------------|
| A086025  | 28 | 25 | 43  | 95  | 60  | 68  | 8.5          | 2.7          |
| A086028  | 32 | 28 | 46  | 108 | 64  | 74  | 9.5          | 3.4          |
| A086032  | 35 | 32 | 52  | 119 | 72  | 83  | 12           | 5.0          |
| A086038  | 42 | 38 | 60  | 146 | 84  | 98  | 17           | 7.8          |
| A086045  | 50 | 45 | 74  | 178 | 105 | 127 | 25           | 13.9         |
| A086052  | 57 | 50 | 83  | 197 | 127 | 138 | 35           | 17.0         |
| A086064  | 70 | 65 | 105 | 255 | 152 | 185 | 55           | 37.0         |

### ROV Release Shackle no. 863

Standard: Dim. according to EN 13889  
 Material: High Tensile Steel, Quenched and Tempered  
 Finish: All load bearing parts hot dip galvanized  
 Safety factor: 5:1  
 Documentation: Test certificate and traceable 3.1 certificate can be supplied on request  
 Temperature: -20 °C to 200 °C



| Art. no. | d1 | d  | a   | c   | d2  | e   | WLL (tonnes) | Weight (kgs) |
|----------|----|----|-----|-----|-----|-----|--------------|--------------|
| A086322  | 25 | 22 | 37  | 84  | 52  | 58  | 6.5          | 1.6          |
| A086328  | 32 | 28 | 46  | 108 | 64  | 74  | 9.5          | 3.4          |
| A086332  | 35 | 32 | 52  | 119 | 72  | 83  | 12           | 5.0          |
| A086338  | 42 | 38 | 60  | 146 | 84  | 98  | 17           | 7.8          |
| A086345  | 50 | 45 | 74  | 178 | 105 | 127 | 25           | 13.9         |
| A086352  | 57 | 50 | 83  | 197 | 127 | 138 | 35           | 17.0         |
| A086364  | 70 | 65 | 105 | 255 | 152 | 185 | 55           | 37.0         |

All dimensions in mm





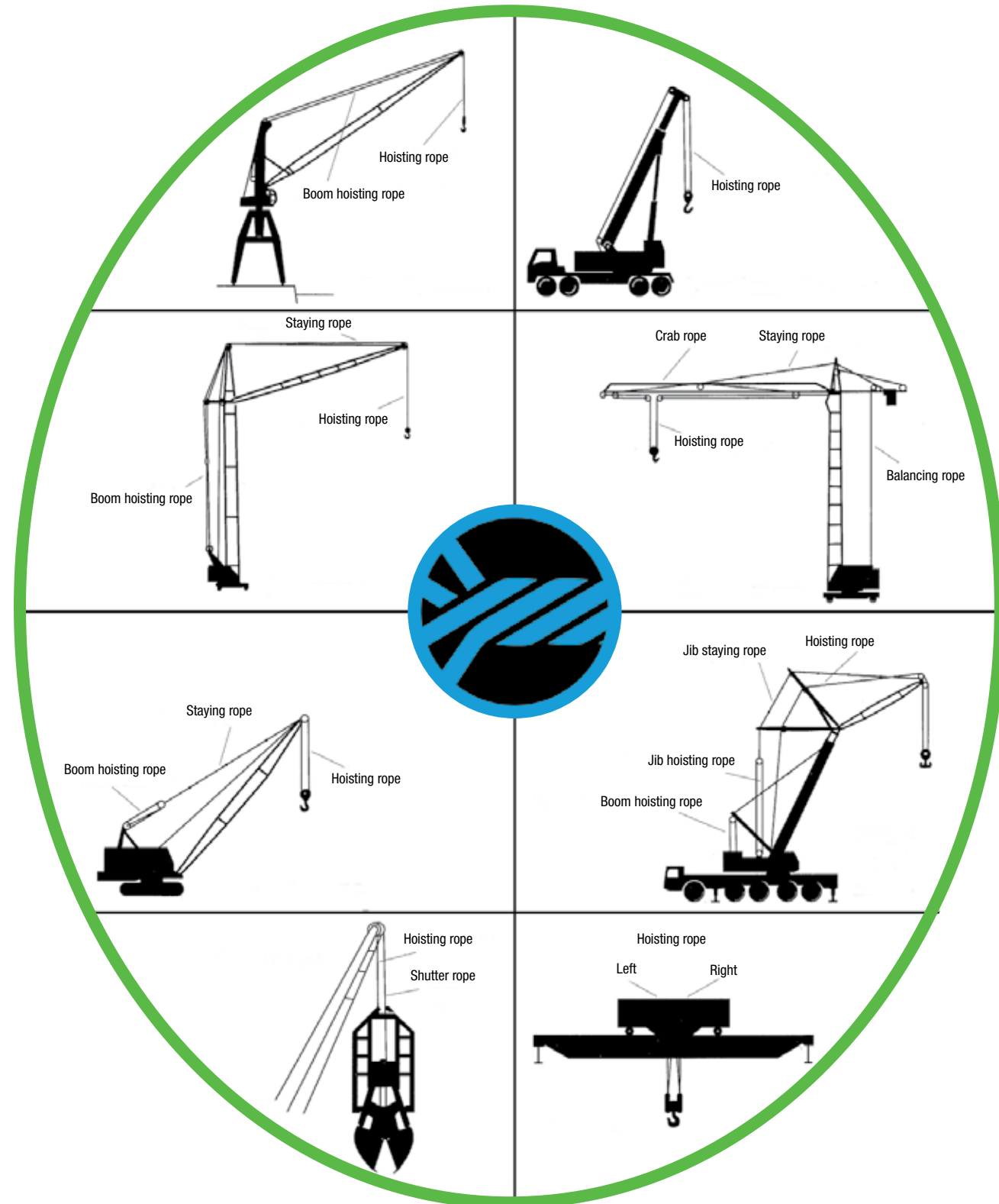


---

Wire Rope and  
Accessories

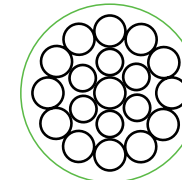
## Technical information

### Crane Types and Rope Names



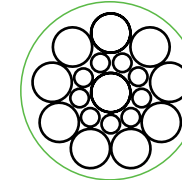
## Strand Designs

### Standard constructions



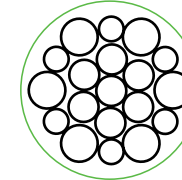
**Round Strand**

All rope wires have the same diameter.



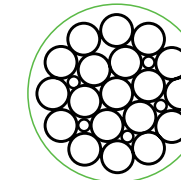
**Seale 1x19 (9/9/1)**

Every layer has a different wire diameter. All layers have the same amount of wires.



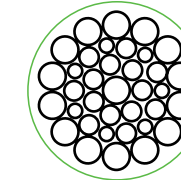
**Warrington 1x19 (6+6/6/6/1)**

The outer layer consists of wires with two different diameters.



**Filler wires 1x25 (12/6F+6/1)**

The wires in the outer and inner layers have the same diameter. The space between the layers is filled up by wires with another diameter.

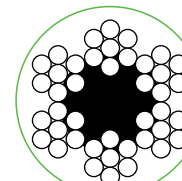


**Warrington - Seale 1x36 (14/7+7/7/1)**

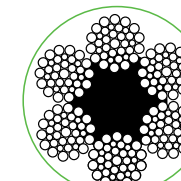
This design is a combination of Warrington and Seale.

## Example of rope sections

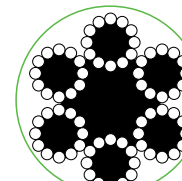
### Standard constructions



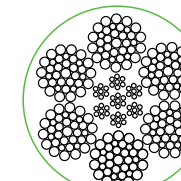
6x7 + FC



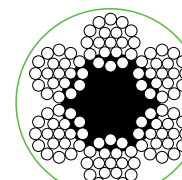
6x36 WS+FC



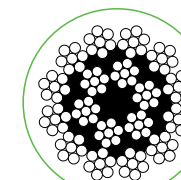
6x12 +7 FC



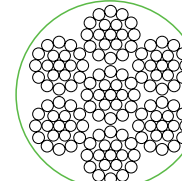
6x36 WS+IWRC



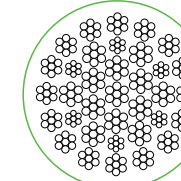
6x19 +FC



18x7 +WSC



6x19 +WSC



35x7

## Standard steel wire

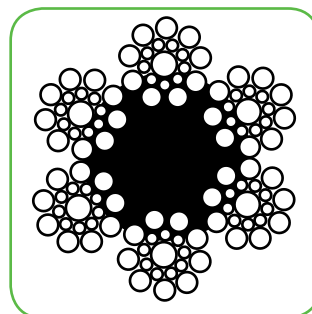
### 6x19 + FC

According to EN 12385-4

Construction: 6x19+FC  
Surface treatment: Galvanized

#### Fields of application

- Cranes
- Lifting equipment
- Hoists
- Elevators
- Winches
- Ski lifts



Fill factor, F = 49%

| Nominal diameter d |        | Approx. mass<br>mm <sup>2</sup> | Weight ca<br>kgs/100 m | Min. breaking load           |                              |
|--------------------|--------|---------------------------------|------------------------|------------------------------|------------------------------|
| mm                 | tol. % |                                 |                        | 1770 N/mm <sup>2</sup><br>kN | 180 kp/mm <sup>2</sup><br>kp |
| 3                  | +8-0   | 3.2                             | 3.0                    | 4.9                          | 500                          |
| 4                  | +7-0   | 5.7                             | 5.4                    | 8.7                          | 887                          |
| 5                  | +7-0   | 9.6                             | 9.0                    | 14.6                         | 1490                         |
| 6                  | +6-0   | 13.8                            | 12.9                   | 21.0                         | 2140                         |
| 7                  | +6-0   | 18.8                            | 17.6                   | 28.6                         | 2920                         |
| 8                  | +5-0   | 24.6                            | 23.0                   | 37.4                         | 3810                         |
| 9                  | +5-0   | 31.2                            | 29.1                   | 47.3                         | 4830                         |
| 10                 | +5-0   | 38.5                            | 35.9                   | 58.4                         | 5960                         |
| 11                 | +5-0   | 46.5                            | 43.3                   | 70.7                         | 7210                         |
| 12                 | +5-0   | 55.4                            | 51.7                   | 84.1                         | 8580                         |
| 13                 | +5-0   | 65.0                            | 60.7                   | 98.7                         | 10100                        |
| 14                 | +5-0   | 75.4                            | 70.4                   | 114                          | 11700                        |
| 16                 | +5-0   | 98.5                            | 91.9                   | 150                          | 15300                        |
| 18                 | +5-0   | 125.0                           | 116                    | 189                          | 19300                        |
| 20                 | +5-0   | 154.0                           | 144                    | 234                          | 23800                        |
| 22                 | +5-0   | 186.0                           | 174                    | 283                          | 28800                        |
| 24                 | +5-0   | 222.0                           | 207                    | 336                          | 34300                        |
| 26                 | +5-0   | 260.0                           | 243                    | 395                          | 40300                        |
| 28                 | +5-0   | 302.0                           | 281                    | 458                          | 46700                        |
| 32                 | +5-0   | 394.0                           | 368                    | 598                          | 61000                        |
| 36                 | +5-0   | 499.0                           | 465                    | 757                          | 77200                        |

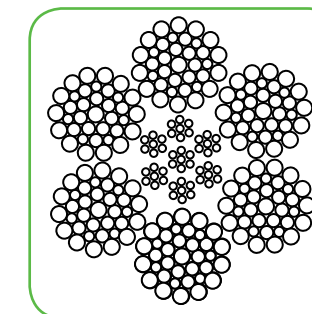
### 6x36 WS + IWRC

According to EN 12385-4

Construction: 6x36 WS + IWRC  
Surface treatment: Galvanized

#### Fields of application

- Cranes
- Winches
- Bar
- Towing
- Offshore
- Elevator
- Forrest winches
- Pile driver
- Excavator



Fill factor, F = 58%

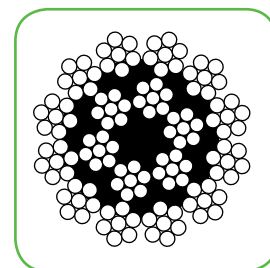
| Nominal diameter d |        | Approx. mass<br>mm <sup>2</sup> | Weight ca<br>kgs/100 m | Min. breaking load           |                              |                              |                              |
|--------------------|--------|---------------------------------|------------------------|------------------------------|------------------------------|------------------------------|------------------------------|
| mm                 | tol. % |                                 |                        | 1770 N/mm <sup>2</sup><br>kN | 180 kp/mm <sup>2</sup><br>kp | 1960 N/mm <sup>2</sup><br>kN | 200 kp/mm <sup>2</sup><br>kp |
| 10                 | +5-0   | 46                              | 40.9                   | 63.0                         | 6420                         | 69.8                         | 7120                         |
| 11                 | +5-0   | 55                              | 49.5                   | 76.2                         | 7770                         | 84.5                         | 8620                         |
| 12                 | +5-0   | 66                              | 58.9                   | 90.7                         | 9230                         | 100                          | 10200                        |
| 13                 | +5-0   | 77                              | 69.1                   | 106                          | 10800                        | 118                          | 12040                        |
| 14                 | +5-0   | 89                              | 80.2                   | 124                          | 12600                        | 137                          | 13970                        |
| 16                 | +5-0   | 117                             | 105                    | 161                          | 16400                        | 179                          | 18260                        |
| 18                 | +5-0   | 148                             | 133                    | 204                          | 20700                        | 226                          | 23050                        |
| 19                 | +5-0   | 166                             | 148                    | 227                          | 23150                        | 252                          | 25700                        |
| 20                 | +5-0   | 182                             | 164                    | 252                          | 25900                        | 279                          | 28460                        |
| 22                 | +5-0   | 220                             | 198                    | 305                          | 31000                        | 338                          | 34480                        |
| 24                 | +5-0   | 262                             | 236                    | 363                          | 36900                        | 402                          | 41000                        |
| 26                 | +5-0   | 308                             | 276                    | 426                          | 43400                        | 472                          | 48140                        |
| 28                 | +5-0   | 357                             | 321                    | 494                          | 50300                        | 547                          | 55790                        |
| 30                 | +5-0   | 410                             | 376                    | 566                          | 57700                        | 628                          | 64060                        |
| 32                 | +5-0   | 466                             | 419                    | 645                          | 65700                        | 715                          | 72930                        |
| 34                 | +5-0   | 532                             | 473                    | 728                          | 74200                        | 800                          | 81600                        |
| 36                 | +5-0   | 590                             | 530                    | 817                          | 83300                        | 904                          | 92200                        |
| 38                 | +5-0   | 664                             | 591                    | 910                          | 92800                        | 1008                         | 102800                       |
| 40                 | +5-0   | 729                             | 654                    | 1010                         | 103000                       | 1120                         | 114200                       |
| 44                 | +5-0   | 882                             | 792                    | 1220                         | 124400                       | 1350                         | 137700                       |
| 48                 | +5-0   | 1050                            | 942                    | 1450                         | 147900                       | 1610                         | 164200                       |
| 51                 | +5-0   | 1184                            | 1100                   | 1640                         | 167000                       | 1816                         | 185230                       |
| 54                 | +5-0   | 1328                            | 1240                   | 1840                         | 188000                       | 2036                         | 207670                       |
| 57                 | +5-0   | 1479                            | 1390                   | 2050                         | 209000                       | 2269                         | 231440                       |
| 60                 | +5-0   | 1694                            | 1560                   | 2270                         | 231540                       | 2514                         | 256430                       |
| 64                 | +5-0   | 1866                            | 1730                   | 2688                         | 274000                       | 2860                         | 291720                       |

## Stainless steel wire

### 18x7 + 1 WSC

According to EN 12385-4

Construction: 18x7 + 1 WSC  
Surface treatment: Galvanized



Fill factor, F = 52%

Fields of application

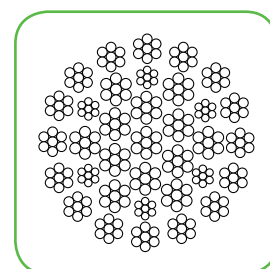
- Building cranes

| Nominal diameter d<br>mm | tol. % | Approx. mass<br>mm <sup>2</sup> | Weight ca<br>kgs/100 m | Min. breaking load           |                              |
|--------------------------|--------|---------------------------------|------------------------|------------------------------|------------------------------|
|                          |        |                                 |                        | 1960 N/mm <sup>2</sup><br>kN | 200 kp/mm <sup>2</sup><br>kp |
| 5                        | +6-1   | 10.2                            | 10.0                   | 15.6                         | 1591                         |
| 6                        | +5-1   | 14.7                            | 14.5                   | 23.1                         | 2350                         |
| 7                        | +5-1   | 20.0                            | 19.7                   | 31.5                         | 3210                         |
| 8                        | +4-1   | 26.1                            | 24                     | 41.1                         | 4190                         |
| 9                        | +4-1   | 33.1                            | 31                     | 52.1                         | 5310                         |
| 10                       | +4-1   | 40.8                            | 38                     | 64.3                         | 6550                         |
| 11                       | +4-1   | 49.4                            | 46                     | 77.8                         | 7930                         |
| 12                       | +4-1   | 58.8                            | 55                     | 92.6                         | 9440                         |

### 35x7 Non-rotating

According to EN 12385-4

Construction: 35x7  
Surface treatment: Galvanized



Fill factor, F = 61%

Fields of application

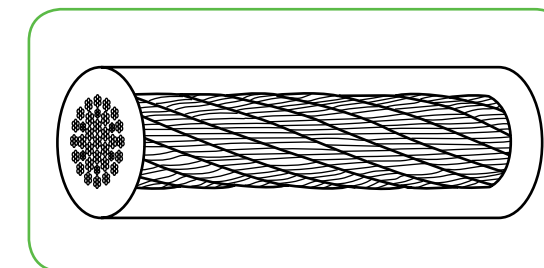
- Building cranes
- Mobile cranes

| Nominal diameter d<br>mm | tol. % | Approx. mass<br>mm <sup>2</sup> | Weight ca<br>kgs/100 m | Min. breaking load           |
|--------------------------|--------|---------------------------------|------------------------|------------------------------|
|                          |        |                                 |                        | 1960 N/mm <sup>2</sup><br>kN |
| 8                        | +5-0   | 30.7                            | 29.1                   | 45.2                         |
| 9                        | +5-0   | 38.9                            | 36.8                   | 57.2                         |
| 10                       | +5-0   | 48.0                            | 45.4                   | 70.6                         |
| 11                       | +5-0   | 58.1                            | 54.9                   | 85.4                         |
| 12                       | +5-0   | 69.1                            | 65.4                   | 102.0                        |
| 13                       | +5-0   | 81.1                            | 76.7                   | 119.0                        |
| 14                       | +5-0   | 94.1                            | 89.0                   | 138.0                        |
| 16                       | +5-0   | 123.0                           | 116.0                  | 181.0                        |
| 18                       | +5-0   | 156.0                           | 147.0                  | 229.0                        |
| 20                       | +5-0   | 192.0                           | 182.0                  | 282.0                        |
| 22                       | +5-0   | 232.0                           | 220.0                  | 342.0                        |
| 24                       | +5-0   | 276.0                           | 262.0                  | 406.0                        |
| 26                       | +5-0   | 324.0                           | 307.0                  | 477.0                        |
| 28                       | +5-0   | 376.0                           | 356.0                  | 553.0                        |
| 32                       | +5-0   | 492.0                           | 465.0                  | 723.0                        |
| 36                       | +5-0   | 622.0                           | 588.0                  | 914.0                        |
| 38                       | +5-0   | 693.0                           | 656.0                  | 1020.0                       |

### PVC-Coated Steel Wire

Fields of application

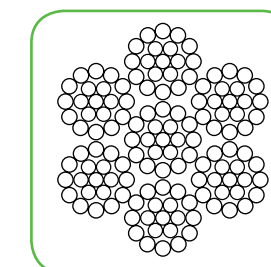
- Locking straps
- Cover wire rope



| Nominal diameter<br>mm | Rope wire                | PVC application | Weight ca<br>kgs/100 m | Min. breaking load<br>vid 1770 N/mm <sup>2</sup><br>kp |
|------------------------|--------------------------|-----------------|------------------------|--|
| 2.0-3.0                | 42 wire FZ               | Clear           | 2.0                    | 248  |
| 3.0-5.0                | 42 wire FZ               | Clear           | 5.0                    | 536  |
| 4.0-6.0                | 42 wire FZ               | Clear           | 8.0                    | 963  |
| 3.0-6.0                | 72 wire FZ TIR           | Clear           | 6.0                    | 338  |
| 4.0-5.5                | 72 wire FZ               | Red             | 7.0                    | 601  |
| 4.0-5.5                | 72 wire FZ               | White           | 7.0                    | 601  |
| 4.0-6.0                | 19 wire Stainless (1570) | White           | 9.0                    | 1400   |

### 6 x 19 + WSC, Stainless Steel

Construction: 6x19+WSC  
Material: AISI 316



Fill factor, F = 52%

Fields of application

- Lifting equipment
- Cranes
- Hoists
- Winches

| Nominal diameter d<br>mm | tol. % | Approx. mass<br>mm <sup>2</sup> | Weight ca<br>kgs/100 m | Min. breaking load           |                              |
|--------------------------|--------|---------------------------------|------------------------|------------------------------|------------------------------|
|                          |        |                                 |                        | 1570 N/mm <sup>2</sup><br>kN | 160 kp/mm <sup>2</sup><br>kp |
| 3                        | +7-1   | 3.9                             | 3.4                    | 4.8                          | 488                          |
| 4                        | +6-1   | 6.9                             | 6.1                    | 9.8                          | 1000                         |
| 5                        | +6-1   | 10.8                            | 9.5                    | 13.1                         | 1330                         |
| 6                        | +5-1   | 15.6                            | 13.8                   | 18.7                         | 1900                         |
| 8                        | +4-1   | 27.6                            | 24.3                   | 33.4                         | 3400                         |
| 10                       | +4-1   | 43.2                            | 38.0                   | 52.1                         | 5300                         |
| 12                       | +4-1   | 62.2                            | 54.7                   | 75.6                         | 7700                         |





# Steel wire equipment

## Load Table for Steel Wire Slings with Fibre Core

The table is based on tensile grade 1770/1960 N/mm<sup>2</sup> and states max. load for the most common wire constructions (Ø 3-7 mm 114-tr 1770N/mm<sup>2</sup>, Ø 8-60 mm 216-tr 1960 N/mm<sup>2</sup>) used for slings.

| Nom. Ø mm | Max WLL i tonnes |         |          |                      |                         |                      |                         |          |             |                      |
|-----------|------------------|---------|----------|----------------------|-------------------------|----------------------|-------------------------|----------|-------------|----------------------|
|           | 1-leg            |         |          | 2-leg*               |                         | 3- & 4-leg*          |                         | Endless  |             |                      |
|           | Straight         | Chocked | U-shaped | α 0°-90°<br>β 0°-45° | α 90°-120°<br>β 45°-60° | α 0°-90°<br>β 0°-45° | α 90°-120°<br>β 45°-60° | Straight | Choke hitch | Parallel choke hitch |
| 3         | 0.09             | 0.07    | 0.18     | 0.12                 | 0.09                    | 0.19                 | 0.13                    | 0.18     | 0.14        | 0.36                 |
| 4         | 0.15             | 0.12    | 0.30     | 0.21                 | 0.15                    | 0.31                 | 0.22                    | 0.30     | 0.24        | 0.60                 |
| 5         | 0.25             | 0.20    | 0.50     | 0.35                 | 0.25                    | 0.50                 | 0.35                    | 0.50     | 0.40        | 1.00                 |
| 6         | 0.35             | 0.28    | 0.70     | 0.50                 | 0.35                    | 0.70                 | 0.50                    | 0.70     | 0.55        | 1.40                 |
| 7         | 0.50             | 0.40    | 1.00     | 0.70                 | 0.50                    | 1.00                 | 0.75                    | 1.00     | 0.80        | 2.00                 |
| 8         | 0.75             | 0.60    | 1.50     | 1.10                 | 0.75                    | 1.60                 | 1.10                    | 1.40     | 1.20        | 3.00                 |
| 9         | 0.90             | 0.80    | 1.80     | 1.26                 | 0.90                    | 2.00                 | 1.40                    | 1.80     | 1.50        | 3.60                 |
| 10        | 1.20             | 0.95    | 2.40     | 1.70                 | 1.20                    | 2.50                 | 1.80                    | 2.40     | 1.90        | 4.80                 |
| 11        | 1.40             | 1.10    | 2.80     | 2.00                 | 1.40                    | 3.00                 | 2.20                    | 2.80     | 2.30        | 5.60                 |
| 12        | 1.70             | 1.30    | 3.40     | 2.40                 | 1.70                    | 3.60                 | 2.60                    | 3.40     | 2.70        | 6.80                 |
| 13        | 2.00             | 1.60    | 4.00     | 2.80                 | 2.00                    | 4.20                 | 3.00                    | 4.00     | 3.20        | 8.00                 |
| 14        | 2.30             | 1.80    | 4.60     | 3.20                 | 2.30                    | 4.80                 | 3.50                    | 4.60     | 3.70        | 9.20                 |
| 16        | 3.00             | 2.40    | 6.00     | 4.20                 | 3.00                    | 6.30                 | 4.50                    | 6.00     | 4.80        | 12.00                |
| 18        | 3.80             | 3.10    | 7.60     | 5.30                 | 3.80                    | 8.00                 | 5.70                    | 7.60     | 6.10        | 15.20                |
| 20        | 4.70             | 3.80    | 9.40     | 6.60                 | 4.70                    | 10.00                | 7.10                    | 9.40     | 7.60        | 18.80                |
| 22        | 5.70             | 4.60    | 11.40    | 8.00                 | 5.70                    | 12.00                | 8.50                    | 11.40    | 9.20        | 23.00                |
| 24        | 6.80             | 5.40    | 13.60    | 9.50                 | 6.80                    | 14.30                | 10.20                   | 13.60    | 11.00       | 27.00                |
| 26        | 8.00             | 6.40    | 16.00    | 11.20                | 8.00                    | 16.80                | 12.00                   | 16.00    | 12.80       | 32.00                |
| 28        | 9.30             | 7.40    | 18.60    | 13.00                | 9.30                    | 19.50                | 14.00                   | 18.60    | 15.00       | 37.00                |
| 32        | 12.00            | 9.70    | 24.00    | 16.80                | 12.00                   | 25.50                | 18.00                   | 24.00    | 19.50       | 48.00                |
| 36        | 15.00            | 12.00   | 30.00    | 21.00                | 15.00                   | 32.00                | 23.00                   | 30.00    | 25.00       | 60.00                |
| 40        | 19.00            | 15.00   | 38.00    | 27.00                | 19.00                   | 40.00                | 28.50                   | 38.00    | 30.00       | 76.00                |
| 44        | 23.00            | 18.00   | 46.00    | 32.00                | 23.00                   | 48.00                | 34.00                   | 46.00    | 37.00       | 92.00                |
| 48        | 27.00            | 22.00   | 54.00    | 38.00                | 27.00                   | 57.00                | 41.00                   | 54.00    | 44.00       | 108.00               |
| 52        | 32.00            | 26.00   | 64.00    | 45.00                | 32.00                   | 67.00                | 48.00                   | 64.00    | 51.00       | 128.00               |
| 56        | 37.00            | 30.00   | 74.00    | 52.00                | 37.00                   | 78.00                | 56.00                   | 74.00    | 60.00       | 148.00               |
| 60        | 43.00            | 34.00   | 86.00    | 60.00                | 43.00                   | 90.00                | 64.00                   | 86.00    | 68.00       | 172.00               |

\* When multiple legs are used in a lift with a choked sling - reduce the value by 20%

When planning a lift where technical data on weight, centre of gravity etc. are known, trigonometry may be used for calculating the maximum load on the lifting equipment. Basis for the calculation is the column for 1-legged slings, on the following formula:

$$WLL = \frac{F_{min} \times KT}{Z_p \times g}$$

where

F<sub>min</sub> = The minimum breaking load of the rope in kN  
 KT = allowed factor for the efficiency of the termination  
 KL = is the leg factor related to the number of legs and the angle to the vertical

Z<sub>p</sub> = safety factor 5

g = 9.81

The calculation yields the max. load on each leg when the lifting angle is 0°, rounded off to the nearest hundred kilos.

## Load Table for Steel Wire Slings with Steel Core

The table is based on tensile grade 1770/1960 N/mm<sup>2</sup> and states max. load for the most common wire constructions (Ø 3-7 mm 133-tr 1770N/mm<sup>2</sup>, Ø 8-60 mm 265-tr 1960 N/mm<sup>2</sup>) used for slings.

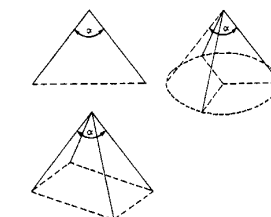
| Wire Ø mm | Max WLL i tonnes |        |          |                      |                         |                      |                         |          |        |          |
|-----------|------------------|--------|----------|----------------------|-------------------------|----------------------|-------------------------|----------|--------|----------|
|           | 1-legged         |        |          | 2-legged*            |                         | 3- & 4-legged*       |                         | Endless  |        |          |
|           | Straight         | Choked | U-shaped | α 0°-90°<br>β 0°-45° | α 90°-120°<br>β 45°-60° | α 0°-90°<br>β 0°-45° | α 90°-120°<br>β 45°-60° | Straight | Choked | U-shaped |
| 3         | 0.10             | 0.08   | 0.20     | 0.14                 | 0.10                    | 0.21                 | 0.15                    | 0.20     | 0.16   | 0.40     |
| 4         | 0.17             | 0.14   | 0.34     | 0.24                 | 0.17                    | 0.36                 | 0.25                    | 0.34     | 0.27   | 0.68     |
| 5         | 0.27             | 0.22   | 0.54     | 0.38                 | 0.27                    | 0.56                 | 0.41                    | 0.54     | 0.43   | 1.08     |
| 6         | 0.38             | 0.30   | 0.76     | 0.53                 | 0.38                    | 0.80                 | 0.57                    | 0.76     | 0.61   | 1.52     |
| 7         | 0.53             | 0.42   | 1.06     | 0.74                 | 0.53                    | 1.10                 | 0.80                    | 1.06     | 0.85   | 2.12     |
| 8         | 0.80             | 0.65   | 1.60     | 1.15                 | 0.80                    | 1.70                 | 1.20                    | 1.60     | 1.30   | 3.20     |
| 9         | 1.05             | 0.80   | 2.10     | 1.45                 | 1.05                    | 2.20                 | 1.80                    | 2.10     | 1.70   | 4.20     |
| 10        | 1.30             | 1.00   | 2.60     | 1.80                 | 1.30                    | 2.70                 | 1.90                    | 2.60     | 2.00   | 5.20     |
| 11        | 1.50             | 1.20   | 3.00     | 2.20                 | 1.50                    | 3.30                 | 2.30                    | 3.00     | 2.50   | 6.00     |
| 12        | 1.80             | 1.40   | 3.60     | 2.60                 | 1.80                    | 3.90                 | 2.80                    | 3.60     | 3.00   | 7.20     |
| 13        | 2.20             | 1.80   | 4.40     | 3.00                 | 2.20                    | 4.50                 | 3.20                    | 4.40     | 3.50   | 8.80     |
| 14        | 2.50             | 2      | 5.00     | 3.50                 | 2.50                    | 5.30                 | 3.80                    | 5.00     | 4.00   | 10.00    |
| 16        | 3.30             | 2.60   | 6.60     | 4.60                 | 3.30                    | 6.90                 | 4.90                    | 6.60     | 5.20   | 13.20    |
| 18        | 4.10             | 3.30   | 8.20     | 5.80                 | 4.10                    | 8.70                 | 6.20                    | 8.20     | 6.60   | 16.40    |
| 20        | 5.10             | 4.10   | 10.20    | 7.20                 | 5.10                    | 10.70                | 7.70                    | 10.20    | 8.20   | 20.40    |
| 22        | 6.20             | 5.00   | 12.40    | 8.70                 | 6.20                    | 13.00                | 9.30                    | 12.40    | 10.00  | 24.80    |
| 24        | 7.40             | 5.90   | 14.80    | 10.30                | 7.40                    | 15.50                | 11.10                   | 14.80    | 11.80  | 29.60    |
| 26        | 8.70             | 7.00   | 17.40    | 12.10                | 8.70                    | 18.20                | 13.00                   | 17.40    | 13.80  | 34.80    |
| 28        | 10.00            | 8.00   | 20.00    | 14.00                | 10.00                   | 21.00                | 15.00                   | 20.00    | 16.00  | 40.00    |
| 32        | 13.00            | 10.40  | 26.00    | 18.40                | 13.00                   | 27.50                | 19.70                   | 26.00    | 21.00  | 52.00    |
| 36        | 16.60            | 13.30  | 33.00    | 23.00                | 16.60                   | 35.00                | 25.00                   | 33.00    | 26.50  | 66.00    |
| 40        | 20.50            | 16.40  | 41.00    | 29.00                | 20.50                   | 43.00                | 31.00                   | 41.00    | 33.00  | 82.00    |
| 44        | 25.00            | 20.00  | 50.00    | 35.00                | 25.00                   | 52.00                | 37.00                   | 50.00    | 40.00  | 100.00   |
| 48        | 29.50            | 23.60  | 59.00    | 41.00                | 29.50                   | 62.00                | 44.00                   | 59.00    | 47.00  | 118.00   |
| 52        | 35.00            | 28.00  | 70.00    | 48.00                | 35.00                   | 73.00                | 52.00                   | 70.00    | 55.00  | 140.00   |
| 56        | 40.00            | 32.00  | 80.00    | 56.00                | 40.00                   | 84.00                | 60.00                   | 80.00    | 64.00  | 160.00   |
| 60        | 46.00            | 37     | 92.00    | 65.00                | 46.00                   | 97.00                | 69.00                   | 92.00    | 74.00  | 184.00   |

\* When multiple legs are used in a lift with a choked sling - reduce the value by 20%

If the table is not used, the max. load must be calculated. The result of the formula shown on previous page, representing the max. load on a 1-legged sling, shall be multiplied by a factor according to the following table:

| Lifting angle | Factor K <sub>L</sub> |     |
|---------------|-----------------------|-----|
|               | No. of legs           |     |
| α             | 2                     | 3-4 |
| 0-90°         | 1.4                   | 2.1 |
| 90-120°       | 1.0                   | 1.5 |

The lifting angle (α) is measured according to the following figures:





---

Polyester Lifting

## Roundslings, Single Cover EN 1492-2

Max WLL: 1–12 tonnes.

- Gunnebo Lifting Roundslings with seamless single cover and protected label, made of 100% high tensile polyester, close-woven sealed material for high wear resistance.
- CE-marked
- Safety factor 7:1
- Gunnebo Lifting roundslings for safe lifting - marked with Gunnebo Lifting manufacturer ID.



| Eff. length | WLL 1 tonnes |            | WLL 2 tonnes |            | WLL 3 tonnes |            | WLL 4 tonnes |            | WLL 5 tonnes |            |
|-------------|--------------|------------|--------------|------------|--------------|------------|--------------|------------|--------------|------------|
|             | Art. no.     | Weight kgs | Art. no.     | Weight kgs | Art. no.     | Weight kgs | Art. no.     | Weight kgs | Art. no.     | Weight kgs |
| 0.5         | M57P101      | 0.2        | M57P201      | 0.3        | M57P301      | 0.4        |              |            |              |            |
| 1           | M57P102      | 0.4        | M57P202      | 0.5        | M57P302      | 0.6        | M57P402      | 0.8        | M57P502      | 1          |
| 1.5         | M57P103      | 0.5        | M57P203      | 0.7        | M57P303      | 1.1        | M57P403      | 1.2        | M57P503      | 1.4        |
| 2           | M57P104      | 0.7        | M57P204      | 1.1        | M57P304      | 1.3        | M57P404      | 1.6        | M57P504      | 1.9        |
| 2.5         | M57P105      | 0.7        | M57P205      | 1.7        | M57P305      | 1.4        | M57P405      | 2          | M57P505      | 2.3        |
| 3           | M57P106      | 1          | M57P206      | 1.5        | M57P306      | 1.8        | M57P406      | 2,3        | M57P506      | 2.7        |
| 4           | M57P108      | 1.4        | M57P208      | 2          | M57P308      | 2.6        | M57P408      | 3.1        | M57P508      | 3.6        |
| 5           | M57P110      | 1.9        | M57P210      | 2.5        | M57P310      | 3.2        | M57P410      | 3.9        | M57P510      | 4.4        |
| 6           | M57P112      | 2.4        | M57P212      | 2.8        | M57P312      | 3.9        | M57P412      | 4.7        | M57P512      | 5.3        |

| Eff. length | WLL 6 tonnes |            | WLL 8 tonnes |            | WLL 10 tonnes |            | WLL 12 tonnes |            |
|-------------|--------------|------------|--------------|------------|---------------|------------|---------------|------------|
|             | Art. no.     | Weight kgs | Art. no.     | Weight kgs | Art. no.      | Weight kgs | Art. no.      | Weight kgs |
| 2           | M57P604      | 2.3        | M57P804      | 3.1        | M571004       | 3.9        | M571204       | 4.9        |
| 2.5         | M57P605      | 3.4        | M570805      | 3.8        | M571005       | 4.8        | -             | -          |
| 3           | M57P606      | 3.4        | M57P806      | 4.5        | M571006       | 5.8        | M571206       | 7.3        |
| 4           | M57P608      | 4.6        | M57P808      | 6          | M571008       | 7.7        | M571208       | 9.6        |
| 5           | M57P610      | 5.7        | M57P810      | 7.5        | M571010       | 9.6        | M571210       | 12         |
| 6           | M57P612      | 6.8        | M57P812      | 9          | M571012       | 11.4       | M571212       | 14.2       |
| 7           | -            | -          | -            | -          | M571014       | 13.2       | M571214       | 16.5       |
| 8           | -            | -          | -            | -          | M571016       | 15.1       | M571216       | 18.8       |

Other sizes can be produced upon request.

## Roundslings, Double Cover EN 1492-2

WLL: 15–30 tonnes

- Gunnebo Lifting Roundslings with side seam, double cover, made of 100% high-tensile polyester, close-woven sealed material for high wear resistance.
- CE-marked.
- Safety factor 7:1
- Gunnebo Lifting roundslings for safe lifting marked with Gunnebo Lifting manufacturer ID.

| Eff. length | WLL 15 tonnes |            | WLL 20 tonnes |            | WLL 25 tonnes |            | WLL 30 tonnes |            |
|-------------|---------------|------------|---------------|------------|---------------|------------|---------------|------------|
|             | Art. no.      | Weight kgs | Art. no.      | Weight kgs | Art. no.      | Weight kgs | Art. no.      | Weight kgs |
| 2           | M471504       | 6.8        | -             | -          | -             | -          | -             | -          |
| 2.5         | M471505       | 8.5        | -             | -          | -             | -          | -             | -          |
| 3           | M471506       | 10.2       | M472006       | 15         | -             | -          | -             | -          |
| 4           | M471508       | 13.5       | M472008       | 20         | M472508       | 25.2       | M473008       | 32         |
| 5           | M471510       | 16.9       | M472010       | 24.9       | M472510       | 31.5       | M473010       | 38.7       |
| 6           | M471512       | 20.2       | M472012       | 29.8       | M472512       | 37.7       | M473012       | 46.4       |



All dimensions in mm

## Webbing Slings Duplex with folded and sleeved eyes EN 1492-1

WLL: 1 – 15 tonnes.

- Gunnebo Lifting flat webbing slings with eyes, made of 100% high-tensile polyester, close woven sealed material for high wear resistance.
- According to standard specifications.
- Gunnebo Lifting webbing sling for safe lifting - marked with Gunnebo Lifting manufacturer ID.



| Eff. length m | WLL 1 tonnes<br>Web. width 30 mm |            | WLL 2 tonnes<br>Web. width 60 mm |            | WLL 3 tonnes<br>Web. width 90 mm |            |
|---------------|----------------------------------|------------|----------------------------------|------------|----------------------------------|------------|
|               | Art. no.                         | Weight kgs | Art. no.                         | Weight kgs | Art. no.                         | Weight kgs |
| 1             | M37P101                          | 0.3        | M37P201                          | 0.6        | -                                | -          |
| 2             | M37P102                          | 0.5        | M37P202                          | 1          | M37P302                          | 1.4        |
| 3             | M37P103                          | 0.7        | M37P203                          | 1.3        | M37P303                          | 2          |
| 4             | M37P104                          | 0.9        | M37P204                          | 1.7        | M37P304                          | 2.5        |
| 5             | M37P105                          | 1          | M37P205                          | 2          | M37P305                          | 3.1        |
| 6             | M37P106                          | 1.3        | M37P206                          | 2.4        | M37P306                          | 3.6        |
| 8             | M37P108                          | 1.4        | M37P208                          | 2.8        | M37P308                          | 4.6        |
| 10            | M37P110                          | 1.8        | M37P210                          | 3.7        | M37P310                          | 5.7        |
| 12            | M37P112                          | 2.1        | M37P212                          | 4.8        | M37P312                          | 6.1        |

| Eff. length m | WLL 4 tonnes<br>Web. width 120 mm |            | WLL 5 tonnes<br>Web. width 150 mm |            | WLL 6 tonnes<br>Web. width 180 mm |            | WLL 8 tonnes<br>Web. width 240 mm |            |
|---------------|-----------------------------------|------------|-----------------------------------|------------|-----------------------------------|------------|-----------------------------------|------------|
|               | Art. no.                          | Weight kgs | Art. no.                          | Weight kgs | Art. no.                          | Weight kgs | Art. no.                          | Weight kgs |
| 6             | M37P406                           | 5.1        | M033506                           | 6.7        | M033606                           | 6.7        | M033806                           | 9.1        |
| 8             | M37P408                           | 6.7        | M033508                           | 8.9        | M033608                           | 8.8        | M033808                           | 11.7       |
| 10            | M37P410                           | 8.4        | M033510                           | 11         | M033610                           | 10.8       | M033810                           | 14.5       |
| 12            | M37P412                           | 9.7        | M033512                           | 13.1       | M033612                           | 12.9       | M033812                           | 17.3       |

Other sizes can be produced upon request.



All dimensions in mm



## Webbing sling - Endless

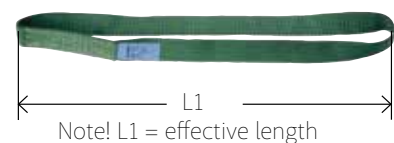
EN 1492-1

WLL: 1-4 Tonnes.

- Gunnebo Lifting flat webbing endless sling made of 100% high-tensile polyester, close-woven sealed material for high wear resistance.
- CE-marked.
- Gunnebo Lifting webbing sling for safe lifting - marked with Gunnebo Lifting manufacturer ID.



| Eff. length | WLL 1 tonnes<br>Webb. width 30 mm |            | WLL 2 tonnes<br>Webb. width 60 mm |            | WLL 3 tonnes<br>Webb. width 90 mm |            | WLL 4 tonnes<br>Webb. width 120 mm |            |
|-------------|-----------------------------------|------------|-----------------------------------|------------|-----------------------------------|------------|------------------------------------|------------|
|             | Art. no.                          | Weight kgs | Art. no.                          | Weight kgs | Art. no.                          | Weight kgs | Art. no.                           | Weight kgs |
| 1           | M30P102                           | 0.2        | M30P202                           | 0.4        | M030030                           | 0.7        | M030040                            | 0.9        |
| 1.5         | M30P103                           | 0.3        | M30P203                           | 0.6        | M30P303                           | 0.9        | M030041                            | 1.3        |
| 2           | M30P104                           | 0.4        | M30P204                           | 0.8        | M30P304                           | 1.2        | M030042                            | 1.6        |
| 2.5         | M30P105                           | 0.5        | M30P205                           | 1          | M30P305                           | 1.5        | M030043                            | 2          |
| 3           | M30P106                           | 0.6        | M30P206                           | 1.2        | M30P306                           | 1.7        | M030044                            | 2.4        |
| 4           | M30P108                           | 0.7        | M30P208                           | 1.5        | M30P308                           | 2.3        | M030045                            | 3.1        |
| 5           | M030008                           | 0.9        | M30P210                           | 1.9        | M30P310                           | 2.2        | M030046                            | 3.8        |
| 6           | M030009                           | 1.1        | M30P212                           | 2.3        | M30P312                           | 3.4        | M030047                            | 4.5        |



Other sizes can be produced upon request.

## Polyurethane Protective Sleeves

Protective sleeves made of polyurethane for roundslings and flat webbing slings can be supplied upon request.

| Art. no. | Inside measurement width x depth | For webbing width | Length | Suits                 |
|----------|----------------------------------|-------------------|--------|-----------------------|
| M890611  | 32 x 11                          | 30 mm             | 1000   | Web. sling 1 tonnes   |
| M890612  | 32 x 11                          | 30 mm             | 2000   | Web. sling 1 tonnes   |
| M890613  | 62 x 11                          | 60 mm             | 1000   | Web. sling 2 tonnes   |
| M890614  | 62 x 11                          | 60 mm             | 2000   | Roundsling 1 tonnes   |
| M890615  | 105 x 11                         | 90 mm             | 1000   | Web. sling, 3 tonnes  |
| M890616  | 105 x 11                         | 90 mm             | 2000   | Roundsling 4 tonnes   |
| M890623  | 130 x 11                         | 120 mm            | 1000   | Web. sling 3 tonnes   |
| M890624  | 130 x 11                         | 120 mm            | 2000   | Roundsling 5 tonnes   |
| M890625  | 156 x 11                         | 150 mm            | 1000   | Web. sling 4 tonnes   |
| M890626  | 156 x 11                         | 150 mm            | 2000   | Roundsling 6/8 tonnes |



## Protective Sleeve for Roundslings

Protective sleeve made of polyester for fitting on roundslings. Velcro tape for easy attachment, no sewing necessary.

| Art. no. | Roundsling (t) | Length |
|----------|----------------|--------|
| M040124  | 1 - 3          | 500    |
| M040125  | 4 - 8          | 500    |
| M040126  | 1 - 3          | 1000   |
| M040127  | 4 - 8          | 1000   |



## Recommended Contact Surface for Polyester Roundsling 7:1

| Tonnes | Min. diameter bolt | Min. free contact width |
|--------|--------------------|-------------------------|
| 1      | 23                 | 35                      |
| 2      | 32                 | 40                      |
| 3      | 35                 | 47                      |
| 4      | 38                 | 50                      |
| 5      | 42                 | 53                      |
| 6      | 46                 | 60                      |
| 8      | 50                 | 67                      |
| 10     | 56                 | 75                      |
| 12     | 58                 | 80                      |
| 15     | 70                 | 96                      |
| 20     | 78                 | 104                     |
| 25     | 84                 | 112                     |
| 30     | 90                 | 120                     |
| 35     | 96                 | 128                     |
| 40     | 102                | 136                     |
| 50     | 120                | 160                     |

Smaller diameter connections and insufficient free contact width, may adversely affect lifting safely and cause serious damage to the roundsling.

## Polyester Lifting Information

When using the sling for the first time, read the manufacturers certificate and instructions/education.

1. Always plan the lift carefully before proceeding with the operation.
2. Always check that the length and WLL stated on the sling label are suitable for the intended use.
3. Examine the sling for damage and defects before use. Never use a damaged or defective sling.
4. Never overload!
5. Make sure that the load is lifted vertically, centred above the point of gravity.
6. Use identical slings in case of multi- legged lifting and take the lifting angles into account when choosing equipment.
7. Do not tie knots on the slings to shorten or join them.
8. Never lift with twisted or entwined slings.
9. Place load-bearing seams and joints between the hook and the load.
10. Protect the sling from sharp edges using edge protection or protective sleeves.
11. Avoid shock loading and snatch lifting.
12. Do not drag the sling, with or without load, on the ground.
13. Keep polyester slings away from alkalis (for example ammonia and caustic soda). If in doubt about exposure to chemicals, check with your supplier.
14. Do not use polyester slings in temperatures over +100°C.
15. Examine slings after use and remove from service if visible damage is discovered.
16. Do not stand under the suspended load or between load and other objects in proximity, to avoid being injured from falling or moving load.
17. To avoid injuries, keep hands, feet and body away from sling, when lifting.

### Maintenance

1. Store the equipment in a dry place.
2. Ensure that seams and labelling are undamaged.
3. The equipment can be cleaned by washing in a petroleum-based detergent and rinsing in water.
4. Roundslings with damaged sleeving, allowing dirt to enter, should be discarded.
5. Roundslings with broken yarns as a result of damaged sleeving must be discarded.
6. Roundslings must be inspected regularly for knots and irregularities, indicating yarn breakage. Discard if found.
7. Webbing slings: Discard in case of serious damage due to friction or wear and tear (appears like a blank and hard or "hair-like" surface).
8. Webbing slings: Discard if/when edge wear/ damage exceeds 5% of its width.
9. Webbing slings: Repair or discard when eye sleeving is worn out.
10. Slings must be regularly inspected, according to local statutory requirements. Records of inspections must be maintained.





---

Height Safety Solutions

107



## Height Safety Innovations

This guide is aimed at giving you an overview of the height safety products that Tractel can offer. We hope that the guide will enable you to choose the best Tractel products to suit your needs. Use the QR codes to watch videos of our harnesses via Tractelly, our YouTube channel.

A full list of product codes & prices can be found at the back of the guide.

Find out what's new...

### Technical Harness Range

We've totally re-vamped our technical harness range. All now include the X-Pad comfort system, integrated fall indicators, the option of elastrac™ boxes and brand new styling. See page 7



### Harness Accessories

We've developed a brand new range of accessories to be used with our harnesses. These include a variety of products for rope access technicians and tree surgeons. See page 15



### EN Standards



### Harnesses

**EN 361:** Personal protective equipment against falls from height. Full body harness suitable for work restraint & fall arrest.

**EN 358:** Personal protective equipment for work positioning & prevention of falls from height. Belts for work positioning, restraint & work positioning lanyards. Normally encompassing side 'D' rings on the waist belt, this allows the user to incorporate a work positioning belt.

**EN 813:** Personal fall protection equipment sit harnesses. These harnesses have a padded sit harness & are suitable for working in full suspension. This includes rope access & activities such as window cleaning. It allows greater comfort for the user & has an attachment point for attaching a descender.

### Lanyards

**EN 354:** Personal fall protection equipment - lanyards.

These can be made from webbing or rope and are suitable for work restraint.

**EN 355:** Personal protective equipment against falls from a height - energy absorbers.

These lanyards have an energy absorbing element & are suitable for fall arrest & restraint.

### HT22

#### Entry Level Multiple Use Harness, EN 361

- Dorsal & sternal attachment points
- 5 adjustment points
- Sub pelvic strap
- Front & rear attachment points
- Available with or without automatic buckles



Attachment Points:



### HT34

#### Multiple Use Harness with Belt, EN 361, EN 358

- Dorsal, sternal & 2 thoracic attachment points
- Complete with CE01 support belt
- 6 adjustment points
- Sub-pelvic strap



Attachment Points:



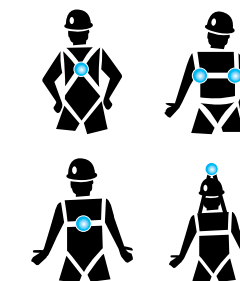
### HT22 R

#### Recovery Harness EN 1497, EN 361

- Dorsal, sternal, over head & thoracic attachment points
- Equipped with an evacuation strap for vertical recovery
- Ideal for use in confined space
- 5 adjustment points



Attachment Points:



### HT54, HT55 & HT56

#### Multiple Use Harnesses, EN 361

##### HT54

- Designed for working in an industrial environment
- Dorsal & thoracic attachment points

##### HT55

- Designed for working in a construction environment
- Dorsal & sternal attachment points

##### HT56

- Designed for working in industrial maintenance & construction
- Dorsal, sternal & thoracic attachment points



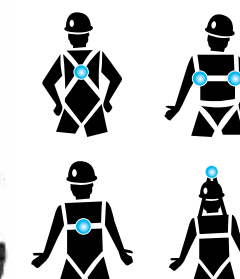
### HT Easyclimb

#### Recovery Harness EN 1497, EN 361

- Designed for climbing up & down ladders equipped with guided type fall arresters
- Patented system offering umbilical attachment point which tears upwards in the event of a fall to end up resting at chest height
- Easy movement with lower attachment point
- Integrated fall indicators
- Integrated X-Pad comfort system
- Available with Elastrac™ option for 4cm of extra movement



Attachment Points:



### HT Electra

#### Utilities Industry EN 358, EN 361, EN 354

- Perfect for use on power lines & pylons
- Complete with rotating belt to increase freedom of movement
- Automatic buckles as standard
- Work positioning harness
- Integrated fall indicators
- Integrated X-Pad comfort system
- Available with Elastrac™ option for 4cm of extra movement



Attachment Points:







### HT Promast

Mast Climbing EN 358, EN 361, EN 813

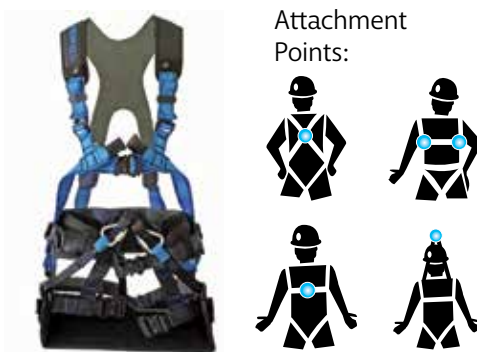
- Mast climbing or rope access harness
- Perfect for long periods of working in suspension
- Complete with webbing attachment loops
- Automatic buckles as standard
- Integrated fall indicators
- Integrated X-Pad comfort system
- Available with Elastrac™ option for 4cm of extra movement



### HT Greentool

Arborist harness EN 358, EN 361, EN 813

- Designed for arborist/tree surgeons
- Equipped with rigid & comfortable work seat
- Easy to don & remove
- Automatic buckles as standard
- Integrated fall indicators
- Integrated X-Pad comfort system
- Available with Elastrac™ option for 4cm of extra movement



### HT Rescue/HT Secours

Rope Access EN 358, EN 361, EN 813

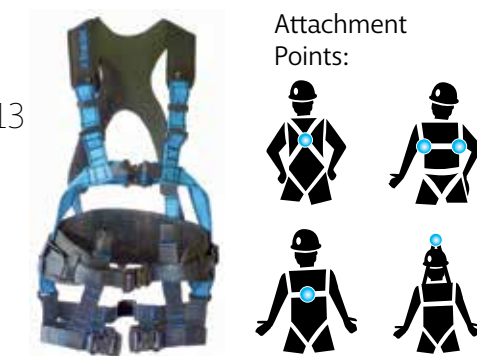
- Designed for working in rope access
- Suitable to attach a chest ascender
- Work suspension harness
- Integrated fall indicators
- Integrated X-Pad comfort system
- Available with Elastrac™ option for 4cm of extra movement



### HT Transport

High movement applications EN 358, EN 361, EN 813

- Designed for applications that require a high level of movement
- Easy to don & remove
- Automatic buckles as standard
- Integrated fall indicators
- Integrated X-Pad comfort system
- Available with Elastrac™ option for 4cm of extra movement



### Harness Product Selector

Try our harness selector to help you find the correct harness for your application:

|              | Automatic buckles as standard | Chest anchorage point | Thoracic anchorage points | Rear attachment point | Tool holder loops | Compatible with seat attachment | Suspension loop for descender | Side 'D' rings | Overhead attachment point |
|--------------|-------------------------------|-----------------------|---------------------------|-----------------------|-------------------|---------------------------------|-------------------------------|----------------|---------------------------|
| HT22         | -                             | ✓                     | -                         | ✓                     | -                 | -                               | -                             | -              | -                         |
| HT34         | -                             | ✓                     | ✓                         | ✓                     | -                 | -                               | -                             | ✓              | -                         |
| HT22 R       | -                             | ✓                     | ✓                         | ✓                     | -                 | -                               | -                             | -              | ✓                         |
| HT54         | -                             | -                     | ✓                         | ✓                     | -                 | -                               | -                             | -              | -                         |
| HT55         | -                             | ✓                     | ✓                         | ✓                     | -                 | -                               | -                             | -              | -                         |
| HT56         | -                             | ✓                     | ✓                         | ✓                     | -                 | -                               | -                             | -              | -                         |
| HT Easyclimb | ✓                             | ✓                     | ✓                         | ✓                     | ✓                 | -                               | -                             | -              | -                         |
| HT Greentool | ✓                             | ✓                     | -                         | ✓                     | ✓                 | ✓                               | -                             | ✓              | -                         |
| HT Electra   | ✓                             | ✓                     | -                         | ✓                     | ✓                 | ✓                               | -                             | ✓              | -                         |
| HT Promast   | ✓                             | ✓                     | -                         | ✓                     | ✓                 | ✓                               | ✓                             | ✓              | -                         |
| HT Rescue*   | -                             | ✓                     | -                         | ✓                     | ✓                 | ✓                               | ✓                             | ✓              | -                         |
| HT Transport | ✓                             | ✓                     | -                         | ✓                     | ✓                 | ✓                               | -                             | -              | -                         |

\*HT Secours

### Rope Access Accessories

#### Ascent Handle

For 8mm to 12mm Kernmantel rope. Conforms to EN 12841/B 06. NFPA L1993:06 6. EN 567:97



#### Foot Loop

Adjustable strap foot loop



#### LSD Jumar Lanyard

Double strap lanyard 32cm & 57cm with 3 M15 connectors to connect the ascent handle to the harness. EN 354 compliant



#### Sternal Ascent

For climbing kernmantel rope 8mm to 12mm. Conforms to EN 1284/B 06. NFPA 1993:06 6. EN 567:97



#### Work Seat

Large, rigid, comfortable work seat equipped with 3 'D' rings to connect tools & equipment.



### Tree Surgeon Accessories

#### Anchoring Lanyard

Allows the removal of the rope from the ground when work is completed.



#### Prussik Knot

Rope loop for tying prussik knots for ascending ropes.



#### Throw Bag

Weighted bag for throwing a guide line over a tree branch to haul ropes.



#### Adjuster Lanyard

Equipped with a braided rope reinforced by steel cable LCM03. EN 358 compliant





**Lanyards**

**LC - Single rope lanyard**

- 1m, 1.5m & 2m options
- Available as twin lanyard
- EN 354



**LCR - Adjustable rope lanyard**

- 1.5m & 2m options
- Fully adjustable
- EN 358



**LCAD - Twin rope lanyard**

- 1.5m & 2m options
- With shock absorber
- EN 355



**LSA - Webbing lanyard**

- 1.5m, 1.75 & 2m options
- With shock absorber
- EN 355



**LPA - Absorber POY lanyard**

- 1.5m, 1.75 & 2m options
- Lightweight & durable
- EN 355



**LSE - Elastic webbing lanyard**

- 1.5m, 1.75 & 2m options
- Flexible & durable
- EN 354



**Blocfor™ Fall Arrest Blocks**

**Blocfor™ 1.8A ESD**



**Blocfor™ 2W**



**Blocfor™ 5 & 6 ESD**



**Blocfor™ 10 AES**



**Blocfor™ 20 & 30**



**Blocfor™ 20R & 30R**



- Fall arrest blocks from 1.5m to 30m
- Blocfor™ 5, 6 & 10 are service free
- Models with AES (Absorbing end system) & ESD (Energy system dissipater) technology, reducing the strength of impact on the user's body even when the cable is completely unwound
- 30m recovery version compatible with our confined space system

**Fixed & Mobile Anchor Points**

**Door Anchor**

- CE EN 795 class B
- Very fast & easy to set up
- Up to 2 users
- Spacing: 1100mm = 1 user  
800mm = 2 users



**Rollclamp**

- Creates a mobile anchor point on an R.S.J
- Available in medium and large
- Adjustable from 120mm to 640mm



**Rollbeam**

- Travels on a lower iron footplate
- Standard CE EN 795 class B



**PA anchors**

- Aluminium anchor point
- Unpainted or painted
- Secured with two M12 screws



**Tracpode**

Confined space kit



**Travsmart**

Lifeline system



**Stopfor K™**

Fall prevention device



**FABA**

Rail systems



**TR2000**

Height safety helmet



**Derope™**

Emergency decent devices





---

Lashings and  
Transport

115



## Chain Tensioner - GT

The chain tensioner from Gunnebo Lifting, GT, is integral in one set. It is made of light weight Grade 10 material and the ratchet handle contributes to a fast and ergonomic lashing procedure. The GT is fitted with safety pins to prevent against unintended release of the threaded end fittings, yet allows for disassembly and convenient repair and replacements of parts, making maintenance easier and faster.

Our chain tensioner is designed to be compatible with the GrabiQ product range, enabling the choice of robust end-hooks with latches. Can also be provided as approved for lifting purposes.



## Unique Benefits With our Chain Tensioner



### Short Handle

- Fully protected ratched mechanism with 8 steps per 90 degree pull, enabling use in very narrow spaces.
- Easy to change direction
- The rubber handle decreases the risk of slipping and is convenient in cold climates

### Open Design

- For easier and faster cleaning and lubrication
- Allows dirt to fall through instead of building up
- Two drain holes in the body prevent water residue.

### Trapezoidal Thread

- Makes the thread less sensitive to dirt and particles
- Low-friction treated for trouble free operation
- Makes lashing faster
- Safety pins prevents unintended unwinding

## The Gunnebo Lifting Chain Lashing System

Gunnebo Lifting offers a complete chain lashing system approved according to EN 12195-3. The system has been developed with focus on the user's needs and working environment, and with safety as highest priority. The unique Midgrab chain shortener saves valuable time and effort, and is a natural part of an efficient and effective chain lashing system.

### End Fitting

Lashing hooks in grade 10, such as the EGKN Sling Hook with a heavy duty latch or the GBK Griplatch Safety Hook. Marked with positive indication of the manufacturer, product designation, size, batch number and grade.

### ID-tag

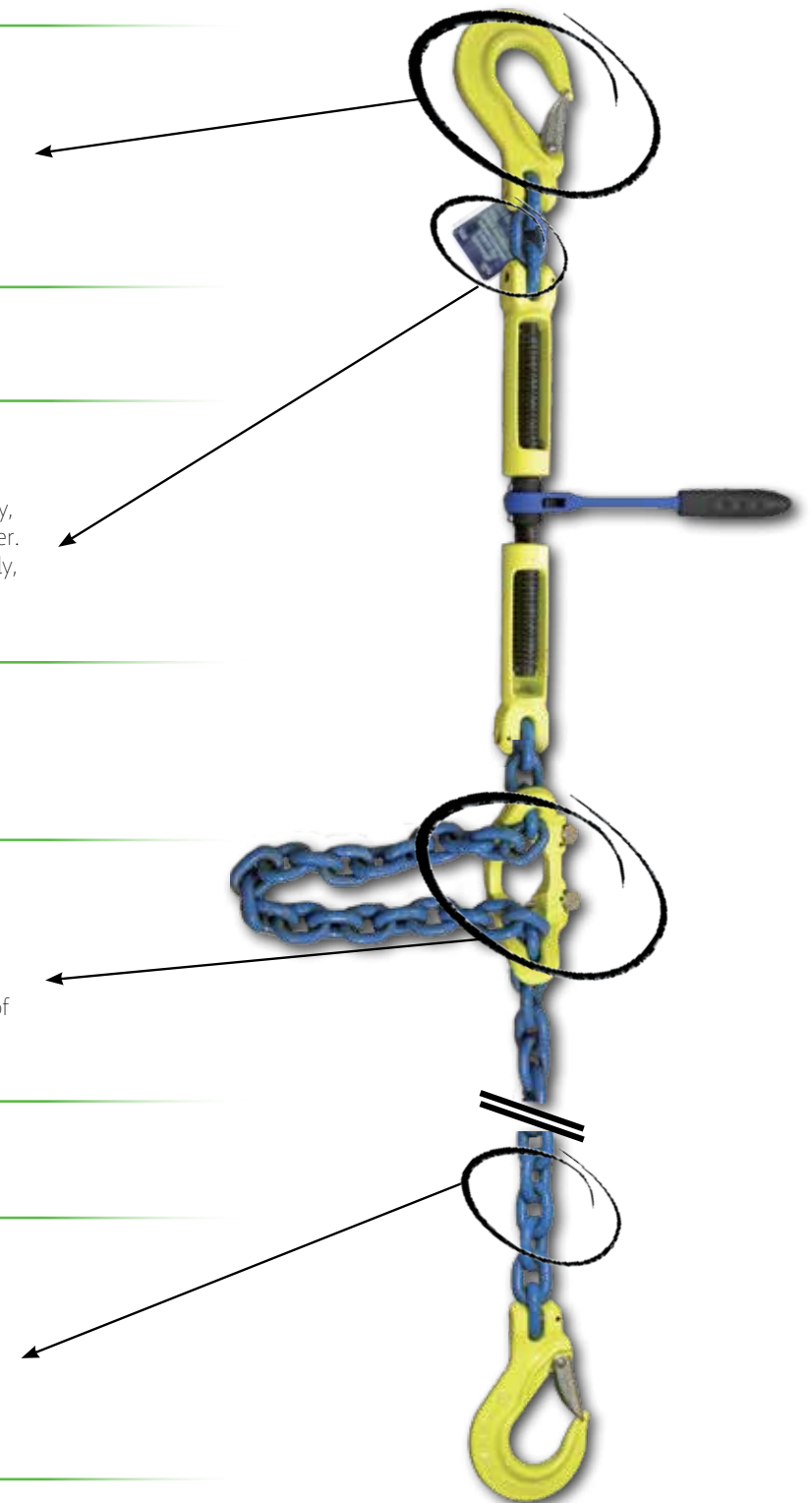
The ID-tag must state the lashing Standard, capacity, tension force, traceability and name of manufacturer. It must also clearly say that the set is for lashing only, lifting is prohibited

### Shortening Function

The Midgrab offers instant mounting on any part of the chain, with the ability to shorten the chain in either direction. It is designed to prevent the chain from disengaging. Marked with positive indication of the manufacturer, product designation, size, batch number and grade

### Chain

Gunnebo Lifting's high tensile short link chain, grade 10 = 1000 N/mm<sup>2</sup> type KLA-10-10, LC = 8000 daN. Surface treatment: Powder coated. ID-marking of the chain: 10G

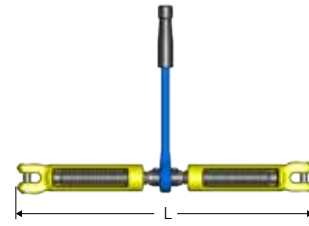






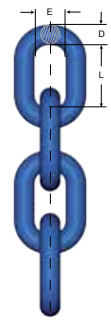
### Chain Tensioner GT

| Model    | Lashing capacity (kN) | STF (daN) | L = Min. length (mm) | L = Max. length (mm) | Weight (kgs) |
|----------|-----------------------|-----------|----------------------|----------------------|--------------|
| GT-8-10  | 50                    | 2400      | 400                  | 600                  | 3.3          |
| GT-10-10 | 80                    | 2400      | 400                  | 600                  | 3.3          |



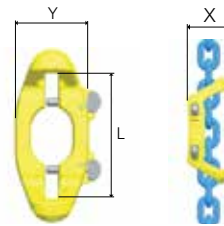
### Chain GrabiQ Grade 10 Short link, KL

| Art. no. | Code      | WLL tonnes | Lashing capacity (kN) | D nom. mm | L » mm | E » mm | Weight kgs/m | MPF kN |
|----------|-----------|------------|-----------------------|-----------|--------|--------|--------------|--------|
| Z802301  | KLA-8-10  | 2.5        | 50                    | 8         | 24     | 11     | 1.5          | 63     |
| Z801921  | KLA-10-10 | 4          | 80                    | 10        | 30     | 14     | 2.3          | 100    |



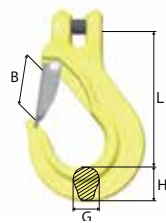
### Midgrab MIG with locking pins

| Art. no. | Code         | WLL tonnes | Lashing capacity (kN) | L   | X  | Y  | Weight kgs |
|----------|--------------|------------|-----------------------|-----|----|----|------------|
| B14303   | MIG CC-8-10  | 2.5        | 50                    | 95  | 50 | 60 | 0.7        |
| B14313   | MIG CC-10-10 | 4.0        | 80                    | 125 | 70 | 77 | 1.1        |



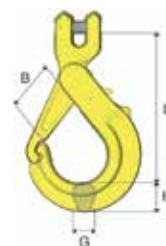
### Sling Hook EGKN

| Art. no. | Code       | WLL tonnes | Lashing capacity (kN) | L   | B  | G  | H  | Weight kgs |
|----------|------------|------------|-----------------------|-----|----|----|----|------------|
| B14461   | EGKN-8-10  | 2.5        | 50                    | 95  | 28 | 17 | 23 | 0.5        |
| B14462   | EGKN-10-10 | 4          | 80                    | 121 | 35 | 23 | 31 | 1          |



### Safety Hook GBK

| Art. no. | Code      | WLL tonnes | Lashing capacity (kN) | L   | B  | G  | H  | Weight kgs |
|----------|-----------|------------|-----------------------|-----|----|----|----|------------|
| Z100759  | GBK-8-10  | 2.5        | 50                    | 119 | 36 | 20 | 22 | 0.8        |
| Z100760  | GBK-10-10 | 4          | 80                    | 150 | 47 | 22 | 29 | 1.4        |



All dimensions in mm

### Lashing 4 - 10 Tonnes European standard EN 12195-2

| Art. no.                  | Description              | Colour | Width | Breaking strength (t) | EN 12195-2 LC daN | EN 12195-2 STF daN |
|---------------------------|--------------------------|--------|-------|-----------------------|-------------------|--------------------|
| Complete lashing          |                          |        |       |                       |                   |                    |
| M275141                   | 0.4+9.5 m with wire hook | Yellow | 75    | 10                    | 3000              | 305                |
| Complete lashing          |                          |        |       |                       |                   |                    |
| M135098                   | 0.4+7.5 m with wire hook | Blue   | 50    | 5                     | 2000              | 340                |
| M136090                   | 0.4+9.5 m with wire hook | Blue   | 50    | 5                     | 2000              | 340                |
| Complete lashing          |                          |        |       |                       |                   |                    |
| M134098                   | 0.4+ 7.5 m wire hook     | Blue   | 50    | 4                     | 1700              | 340                |
| M134090                   | 0.4+9,5 m wire hook      | Blue   | 50    | 4                     | 1700              | 340                |
| M24595W                   | 10m endless              | Blue   | 50    | 5                     | 4000              | 340                |
| Ratchet with short straps |                          |        |       |                       |                   |                    |
| M135051K                  | 0.4m with wire hook      | Blue   | 50    | 4 & 5                 | 200               |                    |



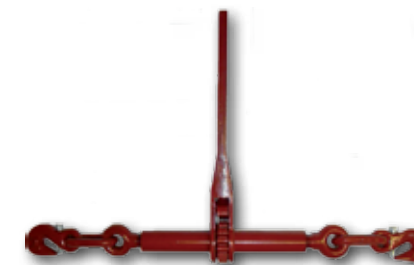
### Lashing 1 - 4 Tonnes European standard EN 12195-2

| Art. no.                   | Description                 | Colour | Width mm | Breaking strength (t) | EN 12195-2 LC daN | EN 12195-2 STF daN |
|----------------------------|-----------------------------|--------|----------|-----------------------|-------------------|--------------------|
| Complete lashing           |                             |        |          |                       |                   |                    |
| M140090                    | 0.5+4.5 m with wire hook    | Orange | 35       | 2.5                   | 1000              | 180                |
| M140091                    | 0.5+5.5 m with wire hook    | Orange | 35       | 2.5                   | 1000              | 180                |
| M14P00W                    | 5 m endless (single web.)   | Orange | 35       | 2.5                   | 1000              |                    |
| Complete lashing stainless |                             |        |          |                       |                   |                    |
| M22210K                    | 0.4+9.5 m with wire hook    | Blue   | 50       | 3                     | 1500              | 305                |
| Complete lashing           |                             |        |          |                       |                   |                    |
| M150101                    | 0,4+3,6 m with sewn-on eyes | Blue   | 26       | 1.5                   | 700               | 150                |
| M150102                    | 0,4+3,6 m with wire hook    | Blue   | 26       | 1.5                   | 700               | 150                |
| M150110                    | 0,5+4,5 m with wire hook    | Blue   | 26       | 1.5                   | 700               | 150                |
| M150103                    | 5 m endless                 | Blue   | 26       | 1.5                   | 700               | 150                |
| Complete lashing           |                             |        |          |                       |                   |                    |
| M151002                    | 0.4+3.6 m with sewn-on eyes | Orange | 25       | 0.7                   | 300               | 100                |
| M151003                    | 0.4+3.6 m with wire hook    | Orange | 25       | 0.7                   | 300               | 100                |
| M151005                    | 0.4+4.5 m with wire hook    | Orange | 25       | 0.7                   | 300               | 100                |
| M151001                    | 5 m endless                 | Orange | 25       | 0.7                   | 300               | 100                |



### Rigging Screw with Ratchet Handle

| Art. no.   | Code    | For chain diam. mm | Breaking strength approx. tonnes |
|------------|---------|--------------------|----------------------------------|
| G009860018 | RS 15 T | 10 mm              | 12.6                             |
| G009860023 | RS 20 T | 13 mm              | 21.6                             |



All dimensions in mm

### Chain Tensioner

Webbing width: 50 mm  
Suits chain LLU 6-11 mm



| Art. no. | Description   | Breaking strength<br>appr. tonnes |
|----------|---|-----------------------------------|
| M129002  | Chain tensioner 0.5 + 1 m,<br>with chain tensioning hook no M161 00D        | 4.5                               |
| M129003  | Chain tensioner 0.5 + 1 m,<br>with twisted flat hook with latch no M016 604 | 5.0                               |

### Lashing for Construction Machinery

#### Rigging Screw with Ratchet Handle

| Art. no.   | Code    | For chain<br>diam. mm | Breaking strength<br>approx. tonnes |
|------------|---------|-----------------------|-------------------------------------|
| G009860018 | RS 15 T | 10-13 mm              | 15                                  |
| G009860023 | RS 20 T | 13-16 mm              | 20                                  |



#### Chain Grade 8 with clevis hooks EGK at both ends

Length = 3.5 meter

| Art. no. | Chain dim. | Suit<br>above rigging<br>screw | Breaking strength<br>approx. tonnes |
|----------|------------|--------------------------------|-------------------------------------|
| Z100099  | 10 mm      | RS 15 tonnes                   | 12.6                                |
| Z100100  | 13 mm      | RS 20 tonnes                   | 21.6                                |



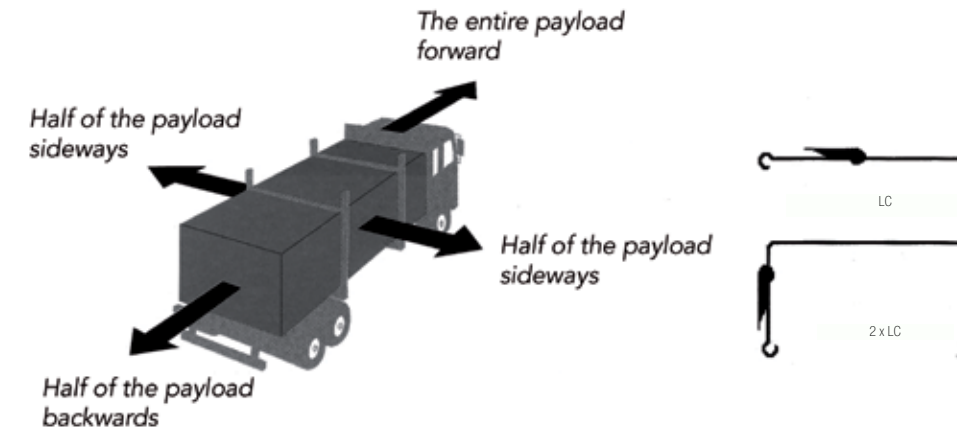
#### Complete Lashing Sets (RS) for construction machinery

| Art. no.   | Contents   |
|------------|--|
| G009860118 | 4 rigging screws RS 15 t. nr G009 860 017<br>4 chains, 10 mm no Z100 099 |
| G009860123 | 4 rigging screws RS 20 t. nr G009 860 022<br>4 chains 13 mm no Z100 100  |



All dimensions in mm

### The lashing must take:



Gunnebo Lifting lashings with a breaking load of 500 kg and above are clearly marked with labels.

The dimensioning of a lashing arrangement must be based on local regulations

### Technical Explanations for: Standard EN 12195-2

**LC = Lashing capacity:** Maximum force for use in straight pull that a web lashing is designed to sustain in use.  
**Safety factor:** 2:1 complete system and metal parts.  
 3:1 non-sewn polyester webbing.  
**Elongation:** Maximum 7% when polyester webbing subjected to the LC.  
**Marked:** Traceability code similar to lifting products. A protected label ensures traceability at all circumstances.





---

Manual Hoists  
and Winches

123





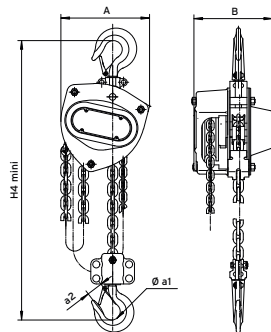
**VHR®** Hand chain hoist for loads of 250 to 5,000 kg

**VHR® Ex** Hand chain hoist for loads of 500 to 20,000 kg

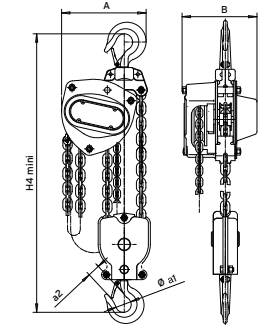
Eye-pleasing, compact and efficient, the V.H.R. is tested to all currently applicable standards.

Technical characteristics

- Machined chain sprocket and gears provide smoother, more efficient operation.
- 3 meters standard lift. Hand chain is 0.5 meters less than lift chain. Non-standard lifts available.
- High strength grade 80 alloy steel load chain with galvanized finish for corrosion resistance (comply with EN 818, safety factor 4).
- VHR's compact design offers safety together with reduced weight. Ideal for construction and maintenance applications.
- Rugged construction featuring steel gearcase and handwheel cover.
- Hooks are alloy steel, heat treated and equipped with hook latches and inspection points.



VHR 1 brin



VHR 2 brins

Options available

A wide range of options is available for this hoist:

- VHR with stainless steel load chain.
- Chain bag.
- VHR with trolley operated by push action on load.
- VHR with short headroom trolley (HPR).
- VHR version Ex – ATEX.
- VHR Ex with Ex short headroom trolley (HPR).

VHR®

Overhung with trolley operated by push action on load type CHD.

| Capacité | A   | B   | Øa1 | a2 | H4 mini | Chaîne   | Nombre de brins | Effort sur la chaîne de manœuvre (kg) | Poids (kg) |
|----------|-----|-----|-----|----|---------|----------|-----------------|---------------------------------------|------------|
| 250 kg   | 121 | 114 | 31  | 21 | 280     | 4 x 12   | 1               | 25                                    | 6,2        |
| 500 kg   | 148 | 132 | 35  | 23 | 345     | 5 x 15   | 1               | 35                                    | 11         |
| 1000 kg  | 172 | 151 | 40  | 27 | 376     | 6 x 18   | 1               | 25                                    | 12,5       |
| 1500 kg  | 196 | 173 | 45  | 33 | 442     | 7,1 x 21 | 1               | 35                                    | 17,8       |
| 2000 kg  | 210 | 175 | 50  | 35 | 470     | 8 x 24   | 1               | 35                                    | 19,5       |
| 3000 kg  | 255 | 205 | 55  | 39 | 548     | 10 x 28  | 1               | 40                                    | 35         |
| 5000 kg  | 280 | 189 | 65  | 45 | 688     | 9 x 27   | 2               | 36                                    | 41,3       |



VHR® Ex

Hand chain hoist in sparkproof version.



Options available

A wide range of options is available for this hoist:

- VHR with stainless steel load chain.
- Chain bag.
- VHR with trolley operated by push action on load.
- VHR with short headroom trolley (HPR).
- VHR version Ex – ATEX.
- VHR Ex with Ex short headroom trolley (HPR).

VHR® Ex

Overhung with travel trolley backed by handwheel and hand chain operation type CHDD (Spark proof version of hoist and trolley).







**ZHR®** Hand chain hoist for loads of 500 to 20,000 kg

**ZHR-HPR®** Low headroom version manual travelling trolley hoist for loads of 500 to 20,000 kg

Technical characteristics

- Overload limiter is standard equipment.
- Four-bearing lifting mechanism.
- Offshore high-resistance RAL 7021 powder coating, 220 µ thick.
- Machined chain sprocket and gears provide smoother, more efficient operation.
- 3 meters standard lift. Hand chain is 0.5 meters less than lift chain.
- Non-standard lifts available.
- High strength grade 80 alloy steel load chain with corrosion-resistant galvanized (complies with standard EN 818, safety factor 4). Made in Europe.
- Galvanized hand chain made in Europe.
- ZHR's compact design offers safety together with reduced weight. Ideal for construction and maintenance applications.
- Steel casing solidly protects chain sprocket, gearcase and handwheel cover.
- Upper and lower alloy steel ISO hooks with safety latches.
- Weston-type load brakes.
- Delivered with CE certificate, and hook and chain certificate.

Options available

A wide range of options is available for this hand chain block:

- ZHR with stainless steel load and hand chain.
- Chain bag.
- ZHR HPN with normal headroom.
- ZHR HPR with short headroom trolley.



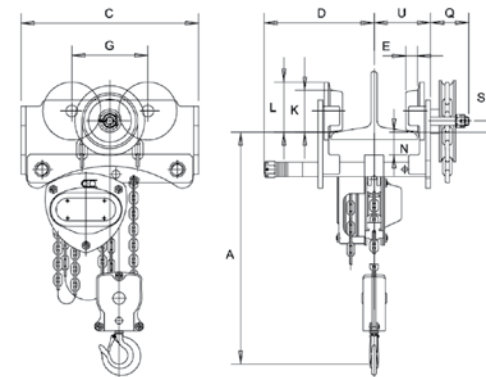
Especially designed for use in areas where optimal use of short headroom is essential.

Technical characteristics

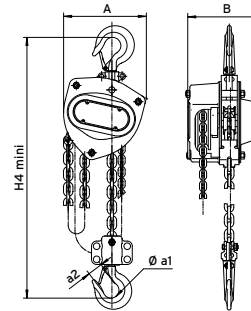
- Characteristics of the hand chain block : see ZHR page 9.
- Controlled via handwheel and chain.
- Easy to adjust for different flange widths up to 305 mm.
- Trolley body made of high-resistance steel.
- Side plates finished with RAL 7021 dark gray coating, 70 µ thick.
- Steel rollers machined for smooth movement.
- Rollers compatible with all types of I and H beams.
- Wheel ball bearings are moisture-tight and maintenance free.
- Galvanized hand chain.
- Fall-prevention brackets and rubber stops.
- Loads up to 20 tons.
- Serial number inscribed on chassis.

Options available

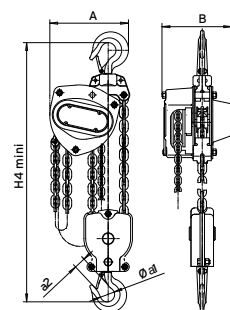
- Ex version with ATEX Marking.
- Stainless steel lift and hand chains.
- Chain bag.



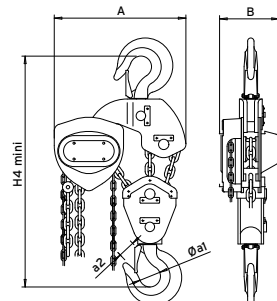
| Load     | A   | B   | Øa1 | a2 | H4 min | Chain    | Number of falls | Pulling force (kg) | Net weight (kg) |
|----------|-----|-----|-----|----|--------|----------|-----------------|--------------------|-----------------|
| 500 kg   | 148 | 132 | 35  | 23 | 345    | 5 x 15   | 1               | 35                 | 11              |
| 1000 kg  | 172 | 151 | 40  | 27 | 376    | 6 x 18   | 1               | 25                 | 12,5            |
| 1500 kg  | 196 | 173 | 45  | 33 | 442    | 7,1 x 21 | 1               | 35                 | 17,8            |
| 2000 kg  | 210 | 175 | 50  | 35 | 470    | 8 x 24   | 1               | 35                 | 19,5            |
| 3000 kg  | 255 | 205 | 55  | 39 | 548    | 10 x 28  | 1               | 40                 | 35              |
| 5000 kg  | 280 | 189 | 65  | 45 | 688    | 9 x 27   | 2               | 36                 | 41,3            |
| 7500 kg  | 433 | 189 | 47  | 67 | 688    | 9 x 27   | 3               | 38                 | 62              |
| 10000 kg | 463 | 189 | 75  | 57 | 765    | 9 x 27   | 4               | 38                 | 78,5            |
| 12500 kg | 430 | 220 | 75  | 54 | 835    | 9 x 27   | 5               | 38,4               | 110             |
| 16000 kg | 718 | 200 | 95  | 71 | 900    | 9 x 27   | 6               | 38,7               | 135             |
| 20000 kg | 840 | 200 | 106 | 85 | 950    | 9 x 27   | 8               | 38,7               | 192             |



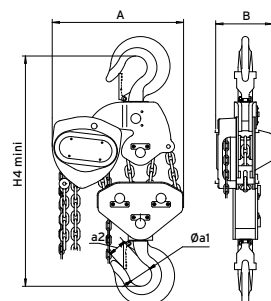
ZHR 1 fall



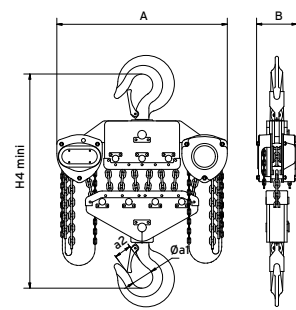
ZHR 2 fall



ZHR 3 fall



ZHR 4 fall



ZHR 5, 6 and 8 fall

| Load     | Dimensions in mm |     |     |    |     |     |     |    |    |    |     |       | Num. of falls | Range | Weight without chain (kg) | Additional weight per m of lifting height (kg) | Pulling force (N) |
|----------|------------------|-----|-----|----|-----|-----|-----|----|----|----|-----|-------|---------------|-------|---------------------------|--|-------------------|
|          | A                | C   | D   | E  | G   | K   | L   | N  | Q  | S  | U   |       |               |       |                           |  |                   |
| 500 kg   | 299              | 258 | 119 | 17 | 100 | 55  | 67  | 29 | 57 | 9  | 95  | 1     | 50-203        | 19    | 1.6                       | 240  |                   |
| 1000 kg  | 331              | 292 | 150 | 18 | 125 | 68  | 82  | 37 | 57 | 18 | 125 | 1     | 64-305        | 37    | 2.1                       | 265  |                   |
| 1500 kg  | 383              | 319 | 156 | 20 | 130 | 74  | 88  | 38 | 57 | 18 | 125 | 1     | 74-305        | 37    | 2.1                       | 265  |                   |
| 2000 kg  | 410              | 358 | 159 | 22 | 135 | 80  | 94  | 38 | 57 | 18 | 129 | 1     | 88-305        | 50    | 2.4                       | 335  |                   |
| 3000 kg  | 461              | 434 | 167 | 25 | 158 | 100 | 115 | 40 | 59 | 8  | 132 | 1     | 100-305       | 65    | 2.5                       | 372  |                   |
| 5000 kg  | 655              | 448 | 177 | 34 | 170 | 108 | 126 | 42 | 59 | 25 | 138 | 2     | 114-305       | 91    | 4.8                       | 360  |                   |
| 7500 kg  | 750              | 624 | 186 | 39 | 190 | 130 | 153 | 45 | 66 | 20 | 146 | 3     | 124-305       | 135   | 7.2                       | 365  |                   |
| 10000 kg | 755              | 636 | 189 | 40 | 200 | 134 | 155 | 45 | 66 | 35 | 148 | 4     | 124-305       | 153   | 9.6                       | 380  |                   |
| 12500 kg | 830              | 668 | 191 | 43 | 200 | 150 | 170 | 50 | 66 | 26 | 150 | 5     | 124-305       | 242   | 12                        | 420  |                   |
| 16000 kg | 930              | 791 | 222 | 50 | 272 | 166 | 196 | 50 | 77 | 8  | 193 | 2 x 3 | 136-305       | 278   | 14.4                      | 400  |                   |
| 20000 kg | 950              | 891 | 229 | 52 | 272 | 172 | 198 | 58 | 77 | 5  | 193 | 2 x 4 | 136-305       | 353   | 19.2                      | 440  |                   |



## ZHV<sup>®</sup> Manual chain hoist for loads of 500 to 50,000 kg



### Technical characteristics

- Epoxy Painting (min. 50 µm).
- Machined chain sprocket and gears provide smoother, more efficient operation.
- High strength alloy steel load chain with corrosion-resistant galvanized
- Galvanized hand chain.
- ZHV's compact design offers safety together with reduced weight. Ideal for construction and maintenance applications.
- Steel casing solidly protects chain sprocket, gearcase and handwheel cover.
- Upper and lower alloy steel ISO hooks with safety latches.
- Delivered with CE certificate.

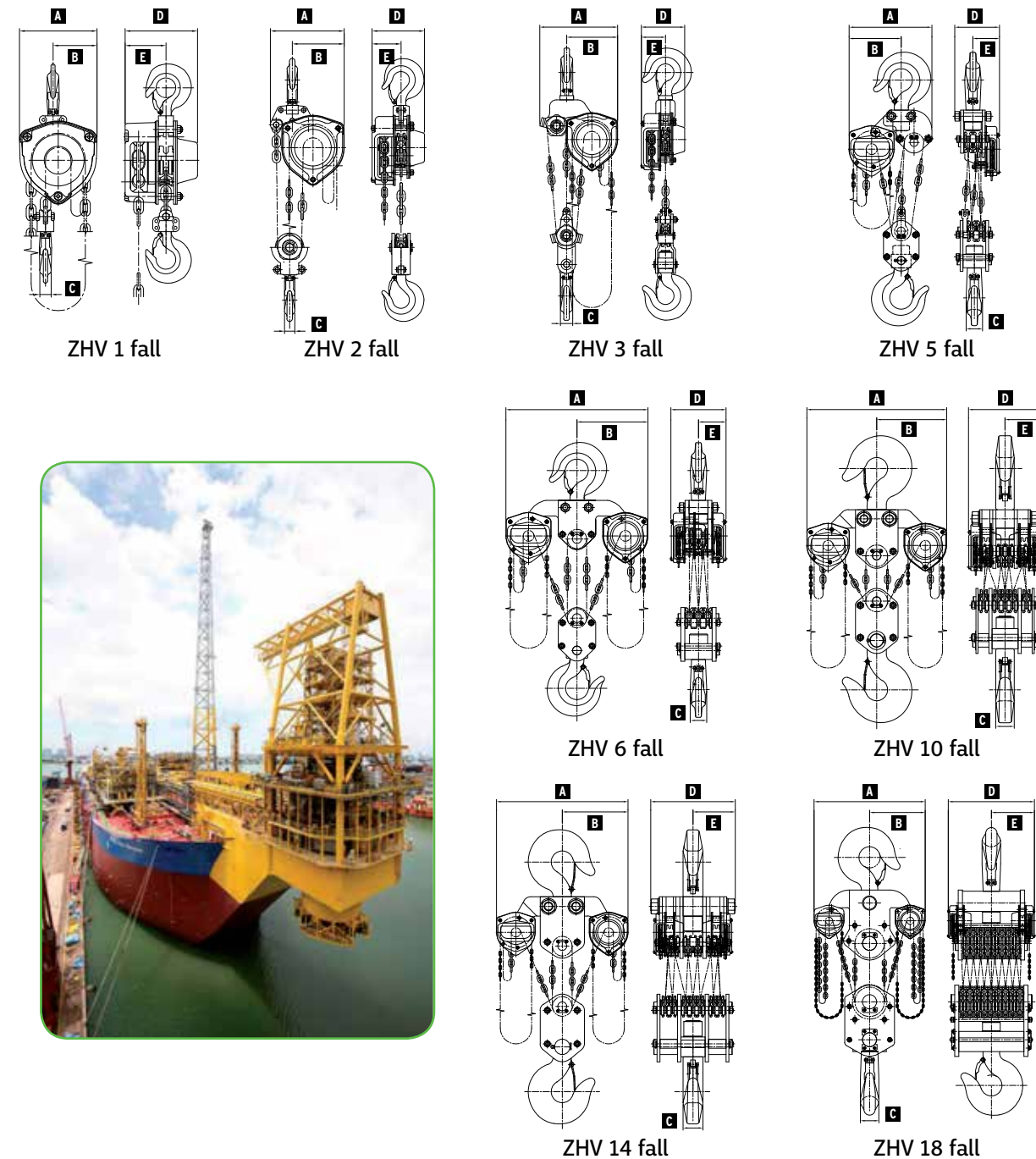
### Options available (according to models)

- ZHV with EX ATEX marking (bronze coated hook, polyester paint,...)
- ZHV full stainless steel (hoist frame, chain, hook,...)
- ZHV with Aluminum Ceramic Coat (min. 30 µm).
- ZHV with Aluminum Ceramic Coat (min. 30 µm) and additional polyester paint.
- ZHV with Offshore paint coating.
- Locking device on trolley, activated by hand chain.
- ZHV with normal headroom trolley (HPN).
- ZHV with short headroom trolley (HPR).
- ZHV with trolley for curved beam (HPNB).
- ZHV with short headroom trolley (HPR).

Large range of surface treatments may be applied.



| Load (kg) | Dimensions in mm |       |      |       |       | Standard height of lift (m) | Length of hand chain (m) | Lifting chain size (mm) | Number of falls | Weight (kg) |
|-----------|------------------|-------|------|-------|-------|-----------------------------|--------------------------|-------------------------|-----------------|-------------|
|           | A                | B     | C    | D     | E     |                             |                          |                         |                 |             |
| 500       | 150              | 85    | 22   | 140   | 79    | 2,5                         | 2,0                      | Ø 6,3 x P 19,0          | 1               | 10,5        |
| 1000      | 150              | 85    | 22   | 140   | 79    | 2,5                         | 2,0                      | Ø 6,3 x P 19,0          | 1               | 10,5        |
| 1000      | 163              | 92,5  | 22   | 149,5 | 84,75 | 2,5                         | 2,0                      | Ø 7,1 x P 20,2          | 1               | 12          |
| 1500      | 163              | 92,5  | 24   | 149,5 | 84,8  | 2,5                         | 2,0                      | Ø 7,1 x P 20,2          | 1               | 13          |
| 1500      | 193              | 110,5 | 28   | 162,3 | 90,25 | 2,5                         | 2,0                      | Ø 7,9 x P 23,0          | 1               | 18          |
| 2000      | 193              | 110,5 | 28   | 162,3 | 90,3  | 3,0                         | 2,5                      | Ø 7,9 x P 23,0          | 1               | 20          |
| 2000      | 224              | 130   | 33   | 175   | 94,5  | 3,0                         | 2,5                      | Ø 9,5 x P 28,6          | 1               | 25,5        |
| 3000      | 228,5            | 160,5 | 32   | 162,3 | 90,25 | 3,0                         | 2,5                      | Ø 7,9 x P 23,0          | 2               | 28,5        |
| 5000      | 291,5            | 190,5 | 45   | 162,3 | 90,25 | 3,0                         | 3,0                      | Ø 7,9 x P 23,0          | 3               | 44          |
| 8000      | 423              | 285   | 68   | 191   | 102   | 3,5                         | 3,5                      | Ø 11,1 x P 33,3         | 3               | 91          |
| 10000     | 423              | 285   | 68   | 191   | 102   | 3,5                         | 3,5                      | Ø 11,1 x P 33,3         | 3               | 91          |
| 15000     | 465              | 293   | 92,4 | 251   | 149   | 3,5                         | 3,5                      | Ø 11,1 x P 33,3         | 5               | 181         |
| 20000     | 798              | 399   | 92,4 | 310   | 155   | 3,5                         | 3,5                      | Ø 11,1 x P 33,3         | 6               | 235         |
| 30000     | 834              | 417   | 110  | 437   | 218,5 | 3,5                         | 3,5                      | Ø 11,1 x P 33,3         | 10              | 492         |
| 40000     | 862              | 431   | 130  | 554   | 277   | 3,5                         | 3,5                      | Ø 11,1 x P 33,3         | 14              | 800         |
| 50000     | 936              | 468   | 156  | 727   | 363,5 | 3,5                         | 3,5                      | Ø 11,1 x P 33,3         | 18              | 1880        |







# ZHV-HPR<sup>®</sup> Hand chain block with low headroom trolley construction for loads of 500 to 50,000 kg

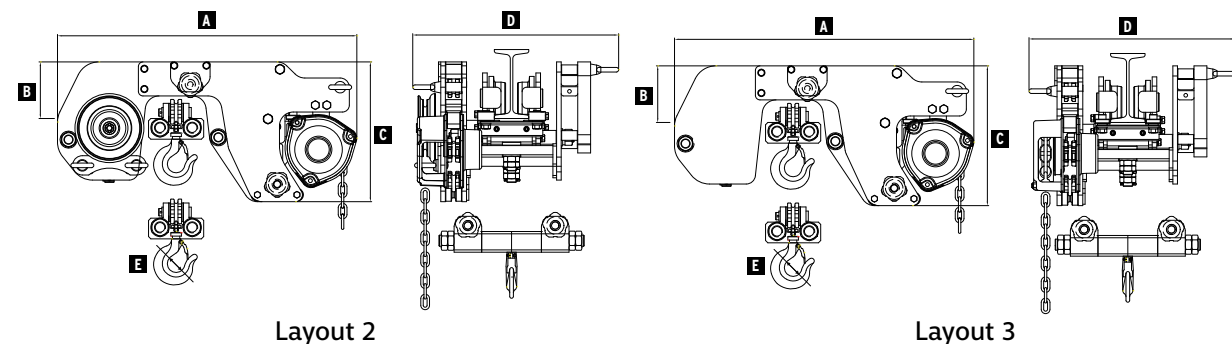
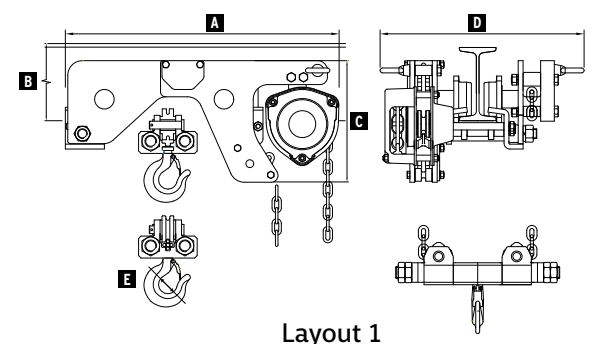


### Technical characteristics

- Epoxy Painting (min. 50 µm).
- Machined chain sprocket and gears provide smoother, more efficient operation.
- High strength alloy steel load chain with corrosion resistant galvanized.
- Galvanized hand chain.
- ZHV's compact design offers safety together with reduced weight.
- Ideal for construction and maintenance applications.
- Steel casing solidly protects chain sprocket, gearcase and handwheel cover.
- Upper and lower alloy steel ISO hooks with safety latches.
- Delivered with CE certificate.

### Options available

- See options of ZHV-CHZ.



### Notes

---

---

---

---

---

---

---

---

---

---

---

---

---

---

---

---

---

---

---

---

---

---

---

---

---

---

---

---

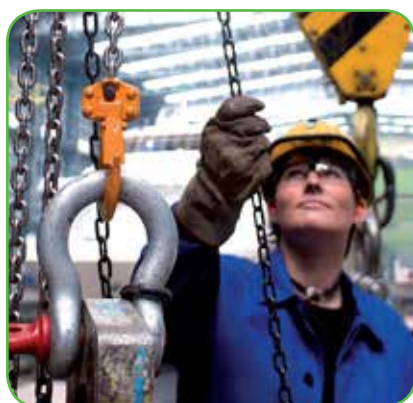
---

---

| Load (kg)  | Dimensions in mm |     |     |       | Standard height of lift (m) | Length of hand chain (m) | Lifting chain size (mm) | Number of falls | Flange width (mm) | Min radius (mm) | Weight (kg) |      |
|--|------------------|-----|-----|-------|-----------------------------|--------------------------|-------------------------|-----------------|-------------------|-----------------|-------------|------|
|  | A                | B   | C   | D     |                             |                          |                         |                 |                   |                 |             |      |
| <b>Layout 1 : Hand chain block ZHR with short headroom push trolley (HPR)</b>                  |                  |     |     |       |                             |                          |                         |                 |                   |                 |             |      |
| 1000   | 561              | 150 | -   | 418   | 38                          | 2,5                      | 2,0                     | Ø 6,3 x P19,0   | 2                 | 75 - 125        | 2900        | 61   |
| 2000   | 560,5            | 150 | 285 | 372,5 | 41                          | 3,0                      | 2,5                     | Ø 7,1 x P20,2   | 2                 | 75 - 150        | 3200        | 64   |
| <b>Layout 2 : Hand chain block ZHR with short headroom geared trolley (HPR)</b>                |                  |     |     |       |                             |                          |                         |                 |                   |                 |             |      |
| 1000   | 652              | 150 | 304 | 448   | 38                          | 2,5                      | 2,0                     | Ø 6,3 x P 19,0  | 2                 | 75 - 125        | 2900        | 59   |
| 2000   | 560,5            | 150 | 285 | 463   | 41                          | 3,0                      | 2,5                     | Ø 7,1 x P 20,2  | 2                 | 75 - 150        | 3200        | 63   |
| 3000   | 691              | 300 | 370 | 568   | 58                          | 3,0                      | 2,5                     | Ø 7,9 x P 23,0  | 2                 | 100 - 150       | 3500        | 150  |
| 5000   | 794              | 300 | 407 | 644   | 64                          | 3,0                      | 3,0                     | Ø 11,1 x P 33,3 | 2                 | 125 - 175       | -           | 195  |
| 10000  | 995              | 350 | 643 | 640   | 86                          | 3,5                      | 3,5                     | Ø 11,1 x P 33,3 | 4                 | 150 - 190       | -           | 460  |
| 20000  | 1460             | 285 | 660 | 1100  | -                           | 3,5                      | 3,5                     | Ø 11,1 x P 33,3 | 6                 | 150 - 190       | -           | 850  |
| 30000  | 1650             | 600 | 655 | 894   | 130                         | 3,5                      | 3,5                     | Ø 11,1 x P 33,3 | 10                | 175 - 190       | -           | 1320 |
| <b>Layout : Hand chain block ZHR with short headroom geared trolley for curved beam (HPNB)</b> |                  |     |     |       |                             |                          |                         |                 |                   |                 |             |      |
| 1000   | 652              | 123 | 304 | 448   | -                           | 2,5                      | 2,0                     | Ø 6,3 x P 19,0  | 2                 | 75 - 125        | 1000        | 98   |
| <b>Layout 3 : Hand chain block ZHR with short headroom push trolley for curved beam (HPNB)</b> |                  |     |     |       |                             |                          |                         |                 |                   |                 |             |      |
| 1000   | 652              | 123 | 304 | 448   | -                           | 2,5                      | 2,0                     | Ø 6,3 x P 19,0  | 2                 | 75 - 125        | 1000        | 93   |

# KITO

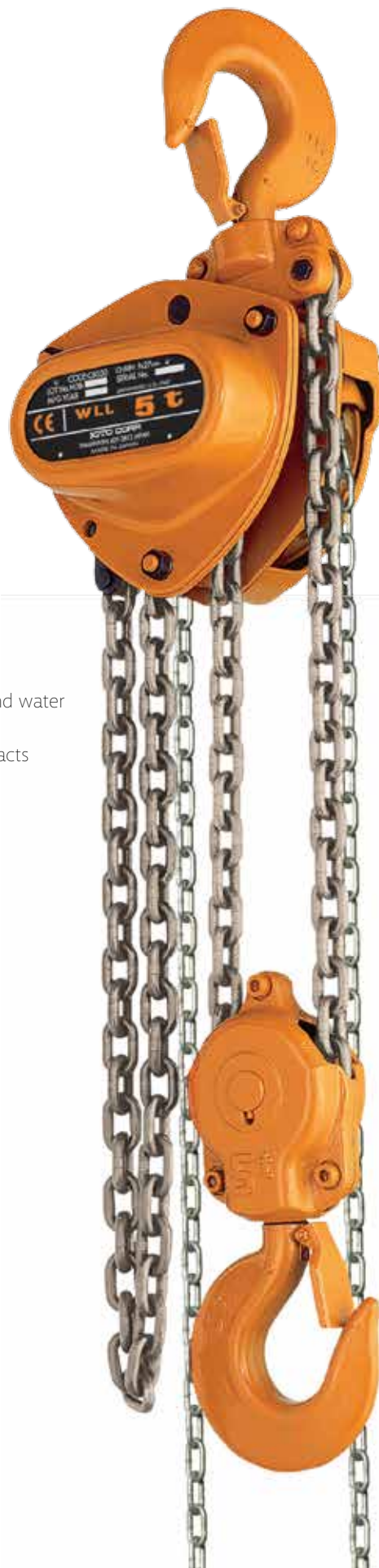
## Manual Chain Hoist CB Model up to 50 t



**Easy handling**  
Long-lasting and reliable



- **Double casing**  
for protection against dust and water
- **Impact proof gear casing**  
resistant against exterior impacts
- **Precise gear mechanism**  
smooth and easy handling
- **Made in Japan**

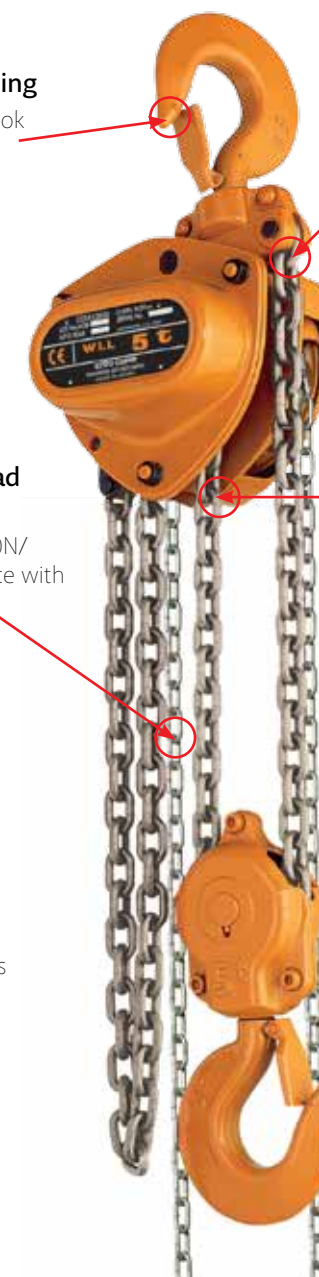


**Wide hook opening**  
top and bottom hook

**High performance brake**  
safety beyond the regular limits

**Nickel plated load chain**  
grade 100 (V) (1000N/mm<sup>2</sup>), in accordance with standard EN 818-7

**Chain guide**  
silent and easy operation



**Optional chain bucket:**

Weather-proof canvas.  
Recommended for large lifting heights

**Optional overload limiter:**

Protects the operator from faulty operation with overload



Option: Universal Trolleys TS model



**Technical data**

| Type  | Capacity, kg | Standard lift, m | Hand pull to lift full load, daN | Chain pulled to lift load 1 meter, m | Load chain diameter, mm | Chain fall | Net weight, kg | Weight for additional 1 m lift, kg |
|-------|--------------|------------------|----------------------------------|--------------------------------------|-------------------------|------------|----------------|------------------------------------|
| CB005 | 500          | 3,0              | 23,5                             | 25                                   | 5,0 x 15,1              | 1          | 11,0           | 1,5                                |
| CB010 | 1000         | 3,0              | 28,4                             | 43                                   | 6,3 x 19,1              | 1          | 12,5           | 1,8                                |
| CB015 | 1500         | 3,0              | 34,3                             | 57                                   | 7,1 x 21,2              | 1          | 15,5           | 2,1                                |
| CB020 | 2000         | 3,0              | 35,3                             | 70                                   | 8,0 x 24,2              | 1          | 20,0           | 2,3                                |
| CB025 | 2500         | 3,0              | 32,3                             | 99                                   | 9,0 x 27,2              | 1          | 27,0           | 2,7                                |
| CB030 | 3000         | 3,0              | 35,3                             | 114                                  | 7,1 x 21,2              | 2          | 24,0           | 3,2                                |
| CB050 | 5000         | 3,0              | 33,3                             | 198                                  | 9,0 x 27,2              | 2          | 41,0           | 4,4                                |
| CB075 | 7500         | 3,5              | 34,3                             | 297                                  | 9,0 x 27,2              | 3          | 63,0           | 6,2                                |
| CB100 | 10000        | 3,5              | 35,3                             | 396                                  | 9,0 x 27,2              | 4          | 83,0           | 7,9                                |
| CB150 | 15000        | 3,5              | 36,3                             | 594                                  | 9,0 x 27,2              | 6          | 155,0          | 11,4                               |
| CB200 | 20000        | 3,5              | 35,3 x 2                         | 396 x 2                              | 9,0 x 27,2              | 8          | 235,0          | 15,8                               |
| CB300 | 30000        | 3,5              | 42,1 x 2                         | 495 x 2                              | 9,0 x 27,2              | 10         | 310,0          | 19,2                               |
| CB400 | 40000        | 3,5              | 42,1 x 2                         | 693 x 2                              | 9,0 x 27,2              | 14         | 480,0          | 26,2                               |
| CB500 | 50000        | 3,5              | 48,0 x 2                         | 792 x 2                              | 9,0 x 27,2              | 16         | 640,0          | 29,7                               |





**PLV<sup>®</sup>**

**Manual Lever Hoist**

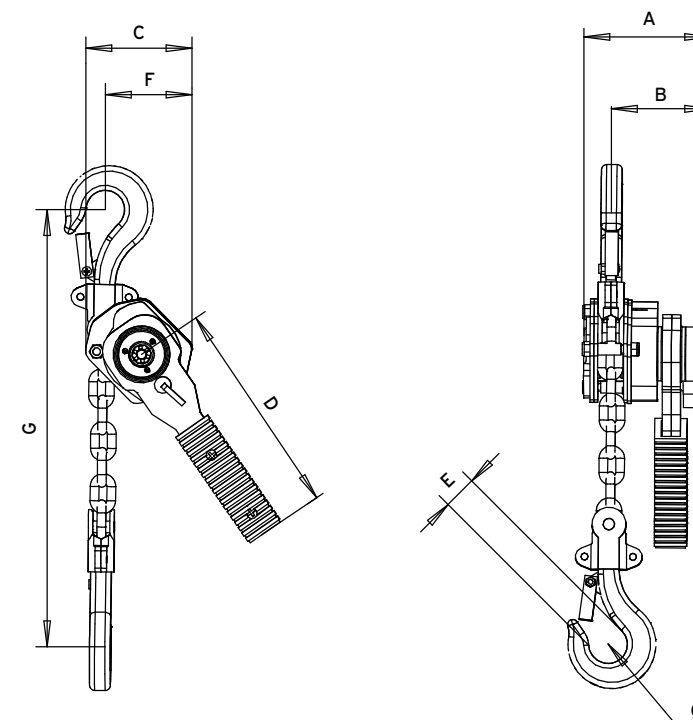
for loads of 250 to 3,000 kg

The PLV Manual Lever Hoist is a compact unit for lifting, pulling and sliding. Especially suitable for industrial use. Easy to handle, this convenient unit can be used for all sorts of jobs anywhere at the production or building. Great for tight spots where headroom is limited.

**Technical characteristics**

- Four good-looking, robust, compact lightweight, easy handling models.
- PLV can be used in any position ; simply switch the lever to make the PLV easier to handle
- Made with special steels, PLV lever hoists are very compact
- The lever hoist – a new concept combining good looks with reliability.
- Chrome-plated steel hoist and lever.
- Reinforced casing effectively protects mechanisms.
- Lever rotates 360°.

- Rubber grip.
- Weston-type load brake with four braking surfaces.
- Braking mechanism fully protected against dust and splashing.
- Extra-safe, lightweight and low-maintenance.
- Chain can be declutched when winch is not loaded.
- High-strength grade 80 steel alloy chain. Galvanized for corrosion resistance.
- Complies with en 818, safety factor 4.
- Made in Europe.
- Delivered with CE certificate, and hook and chain certificate.
- Treated steel alloy upper and lower iso turning hooks with safety latches and inspection points.



| Capacity | A   | B   | C   | D   | E  | F   | G   | Ø  | Lifting height (m) | Num. of falls | Chain diam. (mm) | Weight (kg) |
|----------|-----|-----|-----|-----|----|-----|-----|----|--------------------|---------------|------------------|-------------|
| 250 kg   | 92  | 71  | 70  | 168 | 20 | 50  | 245 | 31 | 1                  | 1             | 4                | 2,1         |
| 750 kg   | 149 | 89  | 128 | 308 | 26 | 85  | 310 | 37 | 1                  | 1             | 6                | 6,2         |
| 1,500 kg | 171 | 102 | 145 | 408 | 36 | 130 | 385 | 45 | 1,5                | 1             | 7                | 9,5         |
| 3,000 kg | 204 | 114 | 203 | 418 | 44 | 150 | 460 | 55 | 1,5                | 1             | 10               | 20,2        |



- Treated steel alloy upper and lower iso turning hooks with safety latches and inspection points.



- Chain can be declutched when winch is not loaded.



- Lever can rotate 360°. Rubber grip.

**Load capacity**

|        | 250 kg | 750 kg | 1500 kg | 3000 kg |
|--------|--------|--------|---------|---------|
| > PLV1 | █      |        |         |         |
| > PLV2 | █      | █      |         |         |
| > PLV3 | █      | █      | █       |         |
| > PLV4 | █      | █      | █       | █       |

# KITO

## Lever Hoist

LB Model  
up to 9 t



### The Original

Constantly developed further and improved

- Unique freewheel chain adjusting mechanism with safeguards against accidental freewheeling under load
- Rugged lever handle
- Smooth geared mechanism for effortless handling
- Light and compact
- Made in Japan



Hook latch with safety tip

KITO Original freewheel chain adjusting mechanism protects from accidental freewheeling

Nickel plated load chain

grade 100 (V) (1000N/mm<sup>2</sup>), in accordance with standard EN 818-7

Fourfold riveted increased safety

### Options:

Kito-Clip\*



Point load hook

for special applications / e.g. in shipbuilding and in sheet metal forming

- LB-OF without freewheel chain adjusting mechanism
- LB-OLL with optional slip clutch

### Technical data valid for all LB models

\*to be used for pulling horizontal loads only

| Type                               | LB008      | LB010      | LB016      | LB025      | LB032     | LB063     | LB090     |
|------------------------------------|------------|------------|------------|------------|-----------|-----------|-----------|
| Capacity, kg                       | 800        | 1000       | 1600       | 2500       | 3200      | 6300      | 9000      |
| Standard lift, m                   | 1,5        | 1,5        | 1,5        | 1,5        | 1,5       | 1,5       | 1,5       |
| Hand pull to lift full load, daN   | 28,4       | 35,3       | 33,3       | 36,3       | 36,3      | 37,2      | 38,2      |
| Load chain diameter, mm            | 5,6 x 15,7 | 5,6 x 15,7 | 7,1 x 19,9 | 8,8 x 24,6 | 10 x 28,0 | 10 x 28,0 | 10 x 28,0 |
| Chain fall                         | 1          | 1          | 1          | 1          | 1         | 2         | 3         |
| Net weight, kg                     | 5,7        | 5,9        | 8,0        | 11,2       | 15,0      | 26,0      | 40,0      |
| Headroom C, mm                     | 280        | 300        | 335        | 375        | 395       | 540       | 680       |
| Weight for additional 1 m lift, kg | 0,7        | 0,7        | 1,1        | 1,7        | 2,3       | 4,7       | 7,0       |





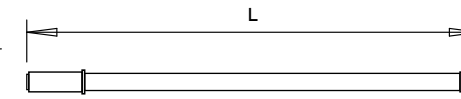
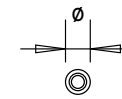
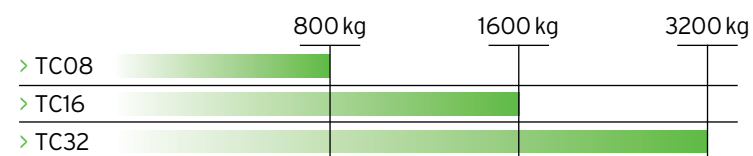
**TLV<sup>®</sup>** Manual lever winch for loads of 800 to 3,000 kg

The TLV winch is designed to lift and pull loads over long distances.

**Technical characteristics**

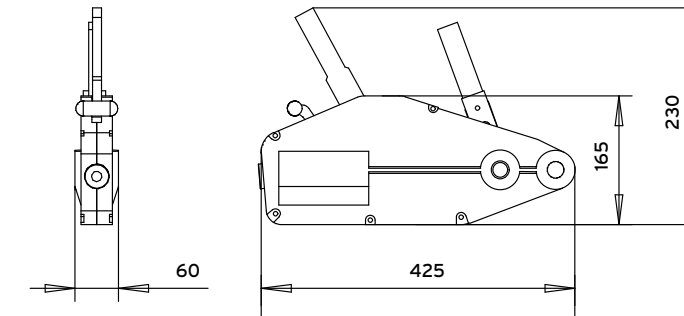
- Designed for lifting and pulling loads over long distances.
- Built with high resistance aluminum, making it light and easy to handle.
- Heavy duty tool suitable for tough working conditions.
- Low maintenance make it suitable for outdoor work.
- Delivered with a 20m / 40m rope.
- Delivered with CE certificate, and hook and chain certificate.

**Load capacity**

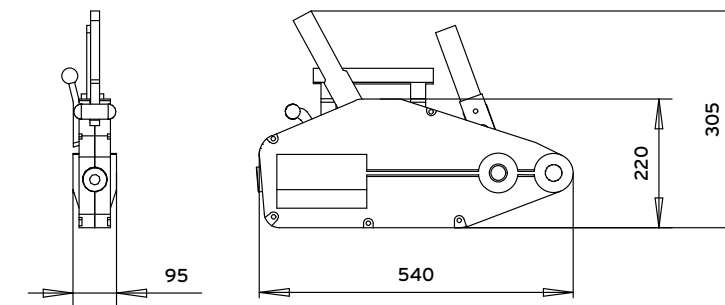


| Type | S.W.L (kg) | Diameter (mm) | L (mm) | L bent (mm) |
|------|------------|---------------|--------|-------------|
| TC08 | 800        | 32            | 790    | -           |
| TC16 | 1600       | 34            | 1121   | 85          |
| TC32 | 3200       | 34            | 1121   | 85          |

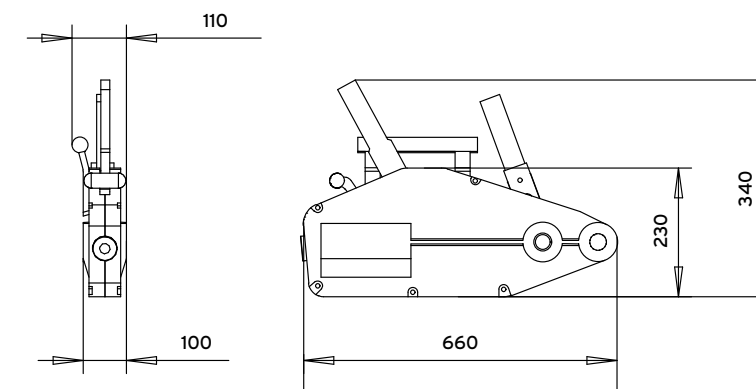
TLV lever



TC08



TC16



TC32

| Type | S.W.L (kg) | Lever length (mm) | Effort on lever (kg) | Rope dis. (mm) | Rope length (m) | Breaking load (kg) | Dimensions (mm) | Net weight (kg) |
|------|------------|-------------------|----------------------|----------------|-----------------|--------------------|-----------------|-----------------|
| TC08 | 800        | 800               | 28,5                 | 8              | 20              | 4800               | 425 x 60 x 230  | 6               |
| TC16 | 1600       | 1120              | 41                   | 11             | 20              | 9600               | 540 x 95 x 305  | 11              |
| TC32 | 3200       | 1120              | 44                   | 16             | 20              | 19200              | 660 x 110 x 340 | 22              |



---

Trolleys and  
Accessories

141





## CHD-CHDD® Manual travel trolley for loads from 250 to 20,000 kg



**CHD®**  
Travel trolley operated by push action on load.

### Technical characteristics

- The distance between flanges can be adjusted as required.
- Travel movement is imparted either by pushing, or by handwheel and chain.
- Delivered ready to assemble in individual boxes.



**CHDD®**  
Travel trolley operated by hand wheel and hand chain.



### Options available

- Stainless steel load chain
- Ex version with ATEX markings.
- Chrome-plated version of trolley available.

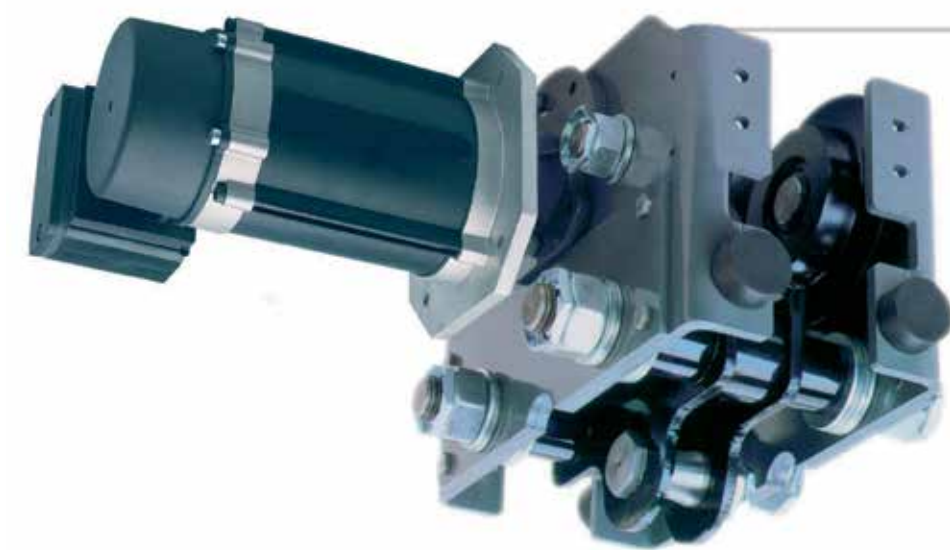


### Load capacity

|        | 250 kg | 500 kg | 1000 kg | 2000 kg | 3000 kg | 5000 kg | 6300 kg | 7500 kg | 10000 kg | 12500 kg | 16000 kg | 20000 kg |
|--------|--------|--------|---------|---------|---------|---------|---------|---------|----------|----------|----------|----------|
| > CHD  |        |        |         |         |         |         |         |         |          |          |          |          |
| > CHDD |        |        |         |         |         |         |         |         |          |          |          |          |

## CHV® Electric variable speed travel trolley for loads of 125 to 5,000 kg

Designed to roll on all profiles type IPN or IPE, HEA or HEB, both straight or curved, the VERLINDE CHV electric trolley enables a hoist with a top hook or EUROCHAIN hoist coupling systems to be hung directly.



### Technical characteristics

- The CHV enables any type of hoisting device to be hung.
- Variable travel movement speed 5 to 20 m/min.
- Gap between flanges adjustable enabling it to be adapted to all types of IPN, IPE, HEA or HEB straight or curved profiles.
- 4 rubber stops
- Trolley complete, ready to connect up.
- IP 55, class F motor protection system.
- Low voltage electrical cabinet.

### Options available

- Worm gear box to obtain reduced travel movement speed (5 or 10 m/min and 10-2.5 m/min).
- Two-speed travel movement (20-5 m/min).
- Low variable speed (3-10 m/min).
- Very low voltage push button box, 1 or 2 speeds and control transformer.
- Limit switch with 1 or 2 steps.
- Other three-phase types of power supply.
- Version with hooking crosshead.



### Load capacity

|         | 125 kg | 1000 kg | 1250 kg | 2000 kg | 2500 kg | 3200 kg | 4050 kg | 5000 kg |
|---------|--------|---------|---------|---------|---------|---------|---------|---------|
| > CHV10 |        |         |         |         |         |         |         |         |
| > CHV20 |        |         |         |         |         |         |         |         |
| > CHV30 |        |         |         |         |         |         |         |         |
| > CHV50 |        |         |         |         |         |         |         |         |



**PRD-PRV®**

Trolleys designed for hand-operated articulated sliding girders system

for loads from 500 to 2,500 kg



Trolleys designed for electrically powered articulated sliding girders

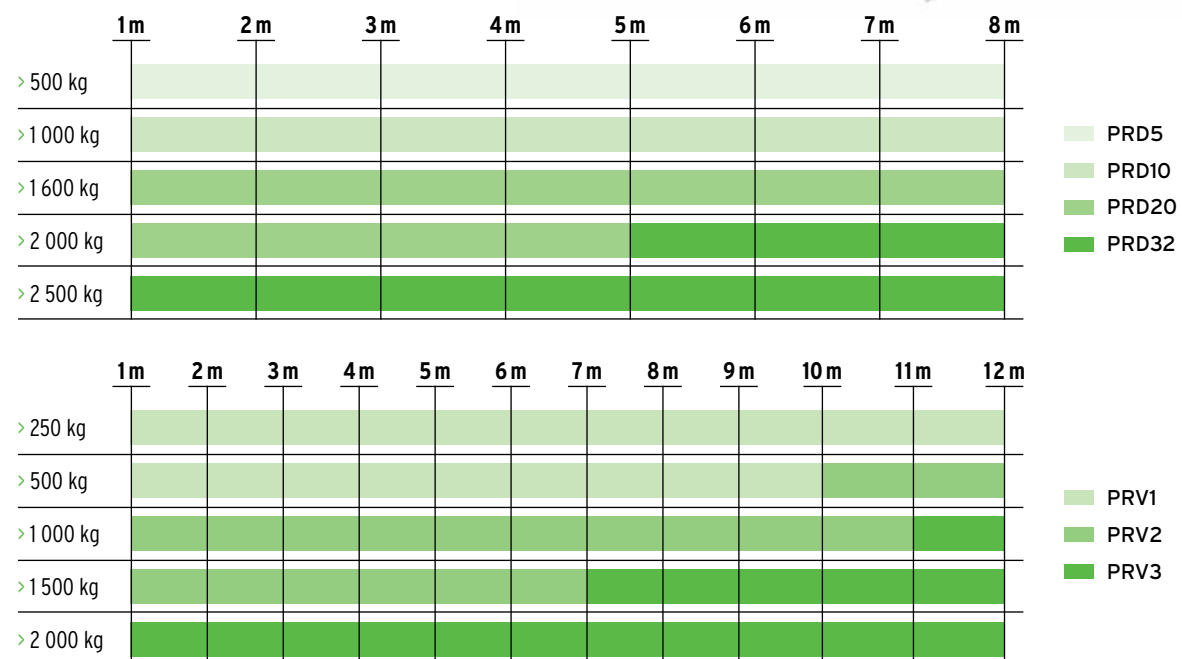
for loads from 250 to 2,000 kg



Example of use of PRD trolley.

The ideal solution for hand-operated articulated sliding girders with spans of up to 8 metres. The PRD offers a low-cost solution for moving loads of 500 to 2,500 kg by pushing them along any type of monorail type steel section.

Span and load capacities



**PAP®** Girder clamp for loads of 1,000 to 5,000 kg



The PAP enables a lifting device to be hooked in fixed position from a girder, an attachment point for hoisting profiles, installation of mechanical limit switch (stop) at low cost... Its applications are limited only by your imagination!



| Model | Capacity (kg) | Distance (mm) | Weight (kg) |
|-------|---------------|---------------|-------------|
| PAP 1 | 1 000         | 75 - 230      | 3,9         |
| PAP 2 | 2 000         | 75 - 230      | 5           |
| PAP 3 | 3 000         | 80 - 316      | 9,5         |
| PAP 5 | 5 000         | 90 - 306      | 11,3        |



---

Electric Hoists  
and Winches

147




**EUROCHAIN VR®**


### Electric chain hoist for loads of 63 to 5,000 kg

Completely innovative, top of the range design, its fluid, contemporary and elegant lines confirm the power of this electric chain hoist. This new generation of EUROCHAIN VR hoists is the result of innovative technology ; new materials, new operating concepts, can adapt to each specific need.



### Technical characteristics

The EUROCHAIN VR electric chain hoist is designed to provide users with the maximum level of safety. It is delivered with the following equipment as standard:

- New lifting nut concept with intermediate teeth for perfect chain drive.
- Torque limiter.
- Disk lifting brake.
- 3m standard lifting height.
- Dual-speed lifting.
- Safety electric end of run for up and down position.
- IP55 lifting and travelling motor.
- Thermal protection on lifting motor.
- Tropic-proof protection (lifting and steering – 90 to 95 %).
- Galvanised lifting chain.
- Disconnectable command cable.
- 2-buttons unit on fixed hoist or push steering carriage.
- 4-buttons unit on hoist coupled to electric steering carriage.
- "Punch" emergency stop button.
- 400V/3Ph/50Hz or 415V/3Ph/50 Hz or 460V/3 Ph/60 Hz power supply.
- Low voltage 48 V command.
- Chain bag.
- 70 mm, RAL 7021 epoxy powder paint.
- Speed variation on travelling – MS Mode (for hoists with an electric trolley).
- Complies with the CE machine directive.



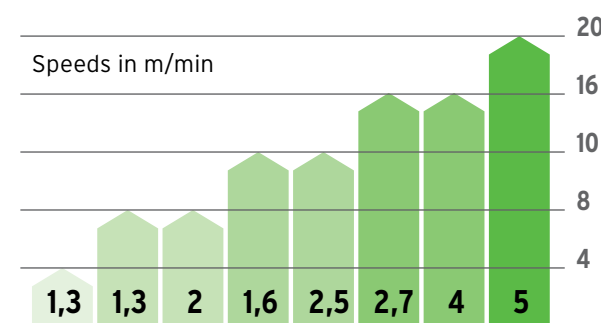
## EUROCHAIN VR®

### Speeds

Wide range of speeds.

25% quicker than the previous generation: 4/1,3; 8/1,3; 8/2; 10/1,6; 10/2,5; 16/2,7; 16/4; 20/5.

The lifting speed ranges have been considerably expanded to enable them to better meet your production constraints and increase productivity, performance, safety and usage on a daily basis.



### Power

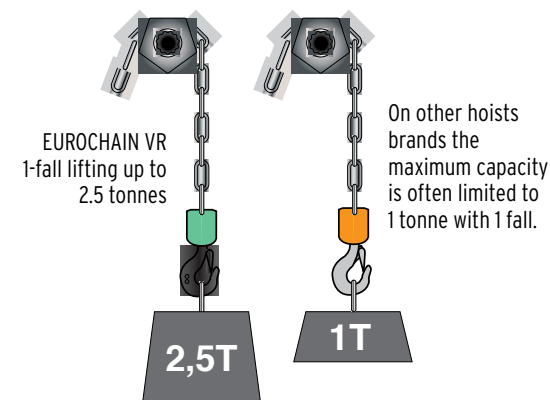
Lifting capacities.

The load spectra for each hoist body have been revised upwards to optimise your lifting equipment investment.

1-fall lifting up to 2.5 tonnes in FEM 2m.

This product advantage offers you the possibility of working at greater lifting heights, with the following benefits:

- Reduction in chain bag dimensions, with a more compact lifting unit.
- Reduction in maintenance costs (fewer lifting chains to be replaced if necessary during maintenance operations).
- Elimination of lifting hook tip-over risks.
- High lifting speeds preserved.



FEM user group up to 3m.

For intensive use of your hoist, up to 300 start-ups per hour!

### Savings

Maintenance operations are now simpler, quicker and more economical:

- Easy access to the brake setting.
- Easy access to the clutch setting.
- Easy access to the fuse.
- Access (workspace) and easy removal of the electric boards by removable plug.

### Safety

Clutch concept.

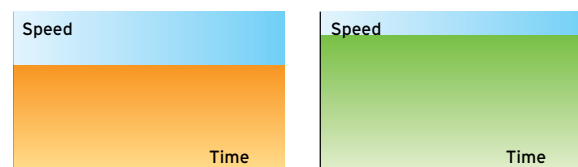
The clutch position in the reducer ensures the load is held by the brake regardless of the machine's daily operating conditions.

Low voltage or direct voltage command.

Enables perfect operation for your usage context (operation in industrial environment, stage lifting, etc.).

Variable speed electric travelling.

The variable speed travelling combined with the high lifting speeds enables flexible and quick working in complete safety for the operator



Load wheel, electric limit switch.

A new patented concept, the 5-pockets lifting nut has 5 intermediate teeth for perfect control over the lifting chain.

This innovation enables better guidance for the chain and avoids any risk of jamming. Increased operating safety and reduced maintenance costs.

The lifting hook's maximum up and down positions are secured by the electric limit switch located under the chain guidance system.

The switches are activated alternately by the lifting hook's upper cone and the slack fall stop.



## Made-to-measure configurations



- Fixed suspended by hook.



- Hooked to a manual or electric trolley in a Eurosystem ALU profile.

- Hooked to a manual or electric trolley in a Eurosystem ST profile.



- Coupled to a pushed or chain driven travelling trolley.



- Coupled to a motorised variable speed travelling trolley.









## STAGEMAKER SR



Industrial chain type electric hoist specially adapted to “show-business” applications for loads of 125 to 5,000 kg\*

### Optional equipment

- Single brake option.
- Pushbutton controller.
- 4, 8, and 12 channel controllers.
- 110VAC or 48VAC control available.
- Single and double flight cases.
- Non rotating hook.
- Suspension eye instead of upper hook.
- Industrial chain guide.

### Innovation

#### PERFECT PUSH



New “Perfect Push”, patented concept, 5 pocket load wheel, fitted with 5 intermediate teeth. This innovation provides improved chain guiding and chain flow, to help reduce the risk of chain jamming.

#### CHAINFLUX



- Design provides a horizontal flow of the chain as it comes off of the load wheel. This design, along with the high strength aluminum construction, allows for a more fluid flow of the chain into the chain bag and helps reduce the risk of chain jamming.
- Drain in housing to avoid water collection in load wheel compartment.

- Rubber buffers located on the hoist corners provide added protection for the hoist.
- Motor design provides consistent speeds when both fully loaded or unloaded.
- Electrical components designed for “plug and play” connectivity.

### Safety

- Double lifting brake as standard for more safety. Stagemaker SR is D8+ ready (after resetting nominal load, divided by 2).
- Clutch concept. the clutch position in the reducer ensures the load is held by the brake regardless of the machine’s daily operating conditions.
- Electrical limit switch as standard on all hoists (version B).
- IP55 protection for the entire hoist.
- Black electro galvanized lifting chain manufactured specifically for Stagemaker.
- All hoist motor as integral thermal protection to prevent overheating (version B).



\*In combination with Stagemaker SM series

### Operating convenience

- Operating sound level down to 60 db (test certificate available).
- Climbing hoist or industrial suspension configuration can be changed simply by reversing the chain container.
- Rotating upper and lower hooks.
- Chaining tool delivered with every hoist.
- High capacity and high strength chain bag made of 1100 denier, high grade black fabric, is both removable and reversible.

**X2**  
**DOUBLE**  
**BRAKE**  
as standard  
**BGV D8+**  
**READY**



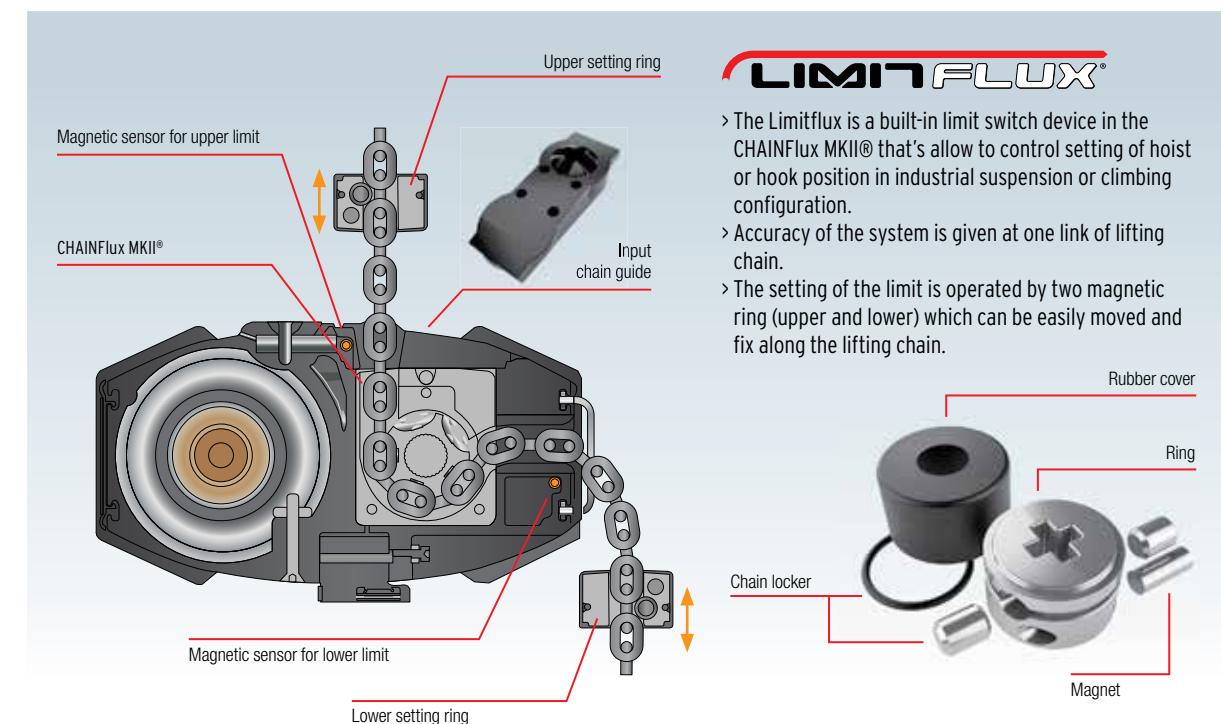
### Improved ergonomics

- Due to oval shape the chain can’t be stuck on top of the motor, this reduce the risk of chain jamming. the design with its flowing and refined lines draws attention to its robustness and on-board technology and gives a strong impression of integral safety. The new streamlining provides STAGEMAKER SR better integration in its operating environment (lighting, loudspeakers, etc.).
- Hoist meets ecology regulations and is RohS compliant.
- The hoist body is powder coated with black, protective 70 µm epoxy paint, allowing it to perform under the most extreme conditions (-20C° to +50 C° / -4 to 122 degrees F).
- Lifting hook has an ergonomic, rubber clad, gripping surface.
- New ergonomic concept for the retractable, rubber clad handgrips, allow for easy transportation of the hoist.

### Savings

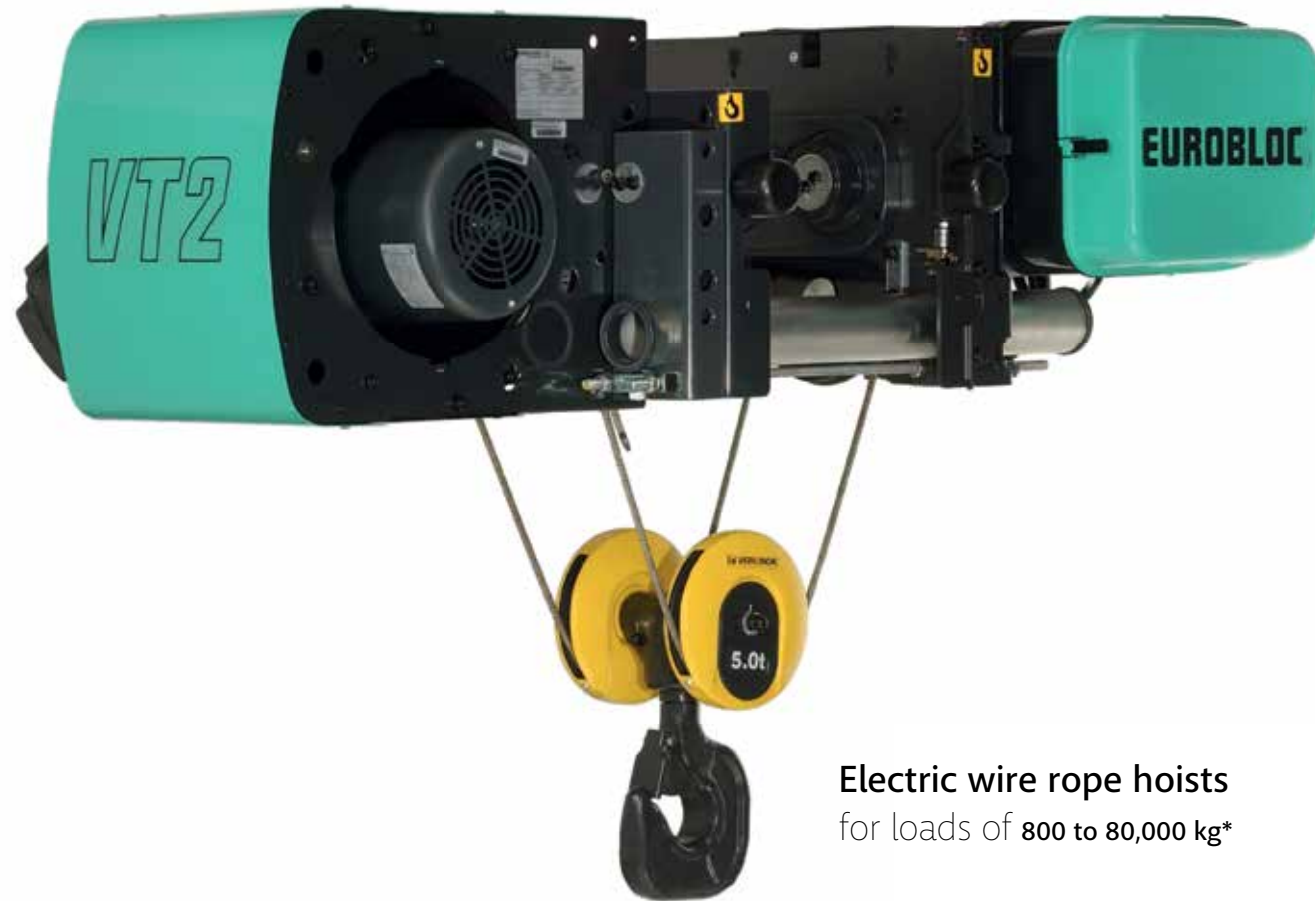
Maintenance operations are now simpler, faster and more economical:

- Easy access to the torque limiter.
- Easy access to safety fuses.
- New concept of easily dismountable hoisting motor.
- Easy access and removal of plug and play electronic boards.
- Easy visual access to the brake for control.





## EUROBLOC VT®



**Electric wire rope hoists**  
for loads of 800 to 80,000 kg\*

VERLINDE has always been in the vanguard for innovative ideas and designs for lifting units with hooks (over 70 patents filed in France and worldwide).

The new EUROBLOC VT electric wire rope hoist has been designed in this resolutely "avant garde" spirit

– 13 patents have been approved from this design alone.



## EUROBLOC® VT9-10-11-12

**Electric wire rope hoists**  
for loads of 10,000 to 250,000 kg\*



The EUROBLOC VT family has now been widened to include the VT9-10-11-12. This line of open winches offers technical solutions to meet your requirements for:

- A greater hoist capacity (10 to 250 tons).
- Lifting height (up to 103,6 m).
- Utilisation group (ISO classification up to M6).
- Hoist speed.
- Speed control (speed variation).



### Technical characteristics

- High performance hoist motor.
- Very high safety level of hoist brake.
- Smart supervision of brake by the variator with slip or jamming detection feature.
- Double safety system for end of travel lifting (limit switches with detection of top and bottom position together with a limit switch tripped by the rope lead-off).
- Travel limit switch as standard.
- Overload protection.
- Winch supervision with Monitor system.
- IP55 and IP66 components.
- Hoist motor insulation class F/H, IP55 protection, thermal protection.
- Epoxy paint (thickness 120 µm).





## The leading French manufacturer of lifting equipment

Leading french manufacturer of lifting equipment. VERLINDE produce in large batches electric wire rope hoist, electric chain hoist, electric belt hoist, electric winches, jib cranes, and cranes components in their fully modernized and enlarged production center of VERNOUILLET (France).

From CAD/CAM design to production by machines amongst the most modern in Europe combined with know-how from a skilled staff, each lifting equipment showing the VERLINDE brand ensures reliability and quality to users.

### New products, new concepts

VERLINDE has always been among the first companies to introduce new ideas for the innovation of hoisting units with a hook (more than 70 patents taken out in France and around the world). The new EUROBLOC VT electric wire rope hoist has been created within this avant-garde spirit, as it accounts for a total of 13 patents on its own.

The EUROBLOC VT electric wire rope hoist is, as of now, the only hoisting unit with wire rope and a hook that offers, in its standard version:

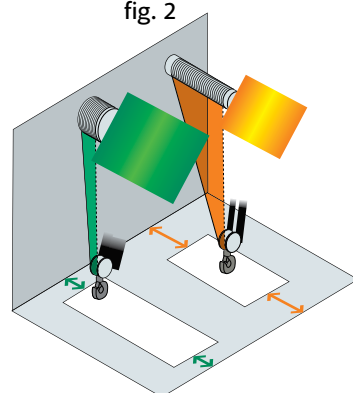
- Hook approach, "C" dimensions and the "F" approach distance of the hoist are the smallest available on the market (fig. 2).
- The pulley block presents only a slight lateral shift during hoisting motion (virtually vertical lifting) (fig. 1).
- The possibility to adjust speed while travelling (fig. 3).

And more equipment to be discovered in the pages that follow.

fig. 1

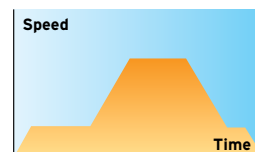
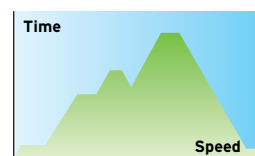


fig. 2



Conventional hoist with traditional design Eurobloc VT

fig. 3



### Technical characteristics

- 2-speed hoisting motor (ratio 1-6) with bimetal sensors. 60% operating factor.
- Maintenance-free DC disc brake.
- 4-position limit switch (up, down, high position deceleration, reversed phase protection).
- Load limiter.
- 3 to 20 m/min variable speed travelling motor.
- Electrical cabinet with low voltage transformer and switchgear. Safety on/off.
- Standard 380V/400V/415V/50Hz, 440V/460V/60Hz power supply.
- IP55 / Class F protection system for motors.
- Tropicalised for travelling and lifting.
- Cable guide for difficult environments.
- Time counter.

MT2, supervisor unit (optional).

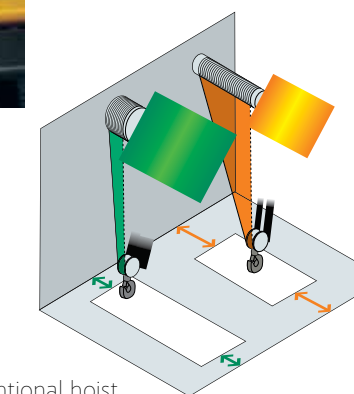


### Advantages

- Virtual vertical lift.
- Compact dimensions.
- Dimension "C" is compact to optimise hoisting height as much as possible.
- Greater accuracy in moving loads, thanks to the variable travel speed (preventing the load from swinging).
- Minimum approach distances.



Short "C" dimension.



Conventional hoist with traditional design Eurobloc VT

### Options available

- Higher travelling speeds.
- Radio remote control.
- MT2 monitor.
- Load limiter with 2 or 3 steps.
- Special supply voltage.
- Load display.
- Explosion proof hoist.

### Load capacity

|            | 2 000 kg | 3 200 kg | 10 000 kg | 20 000 kg | 40 000 kg | 80 000 kg |
|------------|----------|----------|-----------|-----------|-----------|-----------|
| > Type VT1 | █        |          |           |           |           |           |
| > Type VT2 | █        |          |           |           |           |           |
| > Type VT3 | █        |          |           |           |           |           |
| > Type VT4 | █        |          |           |           |           |           |
| > Type VT5 | █        |          |           |           |           |           |







### Customised installations

- Foot mounted or overhead mounted.



- Monorail trolley with standard headroom (HPN).



- Double girder trolley (fixed or suspended).



- Monorail trolley with short headroom (HPR).



- Monorail trolley with short headroom (HPR) and lifting inverter.







## Safety

**Travelling.** Variable travelling speed for precise positioning of loads.

**Wire rope.** in galvanized steel as a standard, high safety factor (factor 4,6 -FEM 2m).

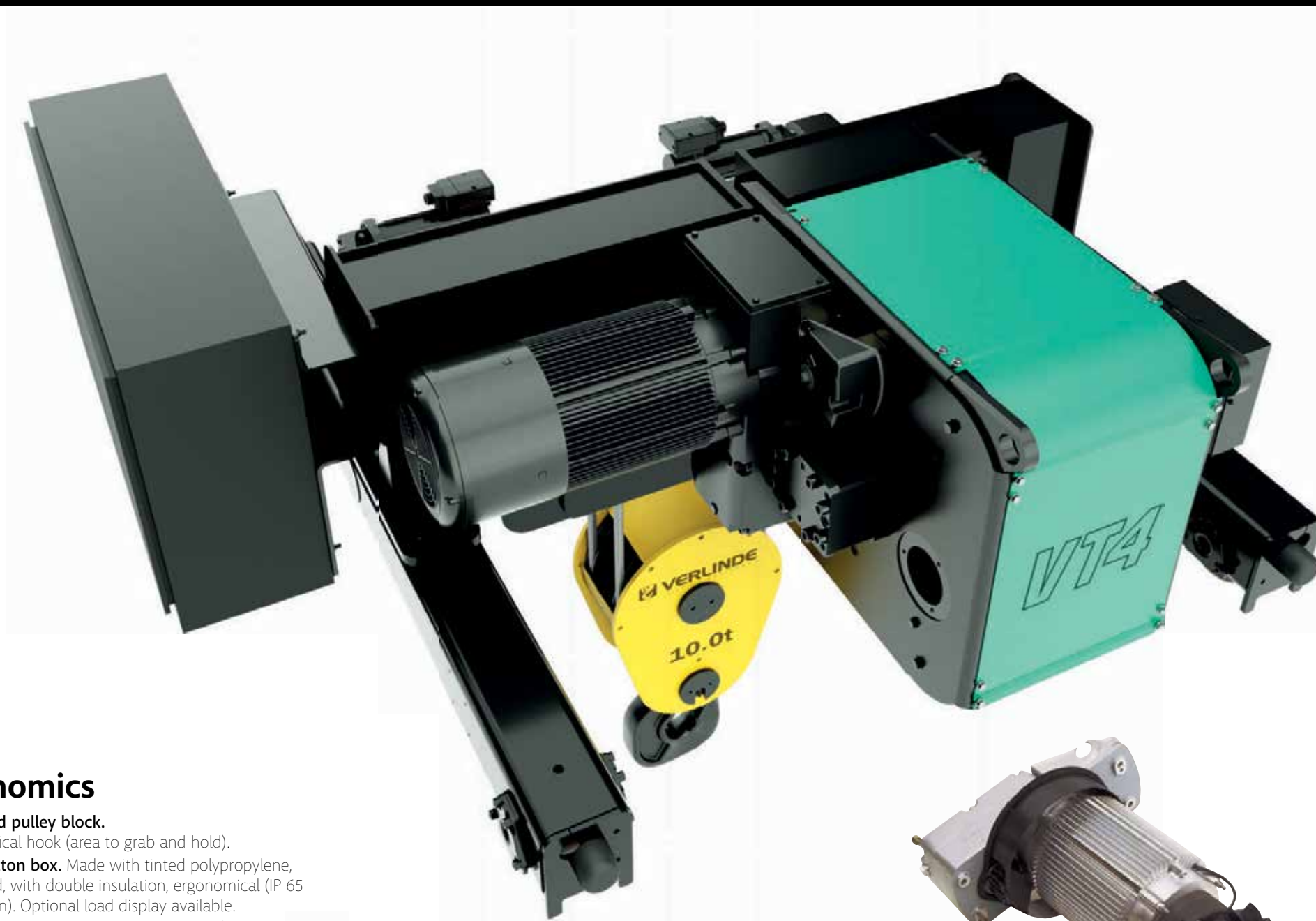
**Electrical cubicle.** The cover can be folded back so that you can store your tools for maintenance (the cover has two steel safety wires to prevent it from falling).

**MT2.** Electronic control of the recording of hoist solicitation status.

**Electrical.** Low voltage control for more safety.

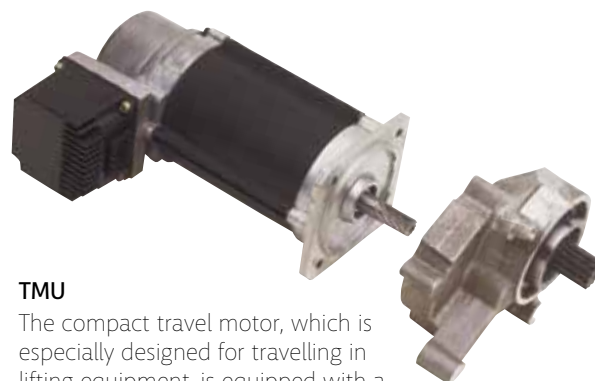
**Traverse wheels.** The 4 steering wheels are fully streamlined for improved safety.

**Hook and pulley block.** Rotating hook and pulley block with safety latch.



## Ergonomics

- **Hook and pulley block.** Ergonomical hook (area to grab and hold).
- **Push button box.** Made with tinted polypropylene, grounded, with double insulation, ergonomical (IP 65 protection). Optional load display available.
- **Electrical cubicle.** Located on the side of the hoist, easily accessible. The open / close system uses a quick closure method.



### TMU

The compact travel motor, which is especially designed for travelling in lifting equipment, is equipped with a variable speed system that is a standard equipment. Maximum speed range is 2 to 32 m/min. IP 55 protection. The motor is designed to ease any necessary maintenance:

- "Intelligent" easy system for motor positioning and assembly onto the trolley.
- The motor receives power from a single plug that can be unbound easily.



### Hoisting Motor and Brake

Designed specifically for lifting, the 2-speed hoisting motor comes with all the necessary protections:

- Type IP 55 protection and F insulation class.
- Bimetal sensor.
- Cooling fins enlarged significantly to encourage heat dissipation.

## Easy maintenance

**Hoisting motor.** Motor cooling increased by 30 % (tunnel effect).

**Hoisting brake.** The brake is tested for hoist longevity under normal use conditions.

**Steering motor-reducer.** Steering reducer with one rail and a permanently lubricated connection.

**Drum.** The drum has been completely covered for better protection.

**Rope guide.** Built "without spring" so that it can be more easily replaced during maintenance.

**Electrical cubicle.** The wires go in and out by means of steel plugs that can be unbound and that are built into the case.

**MT2.** Calculation of the SWP (Safe Working Period). Assembly is in modules, for easier management of spare parts for replacement.

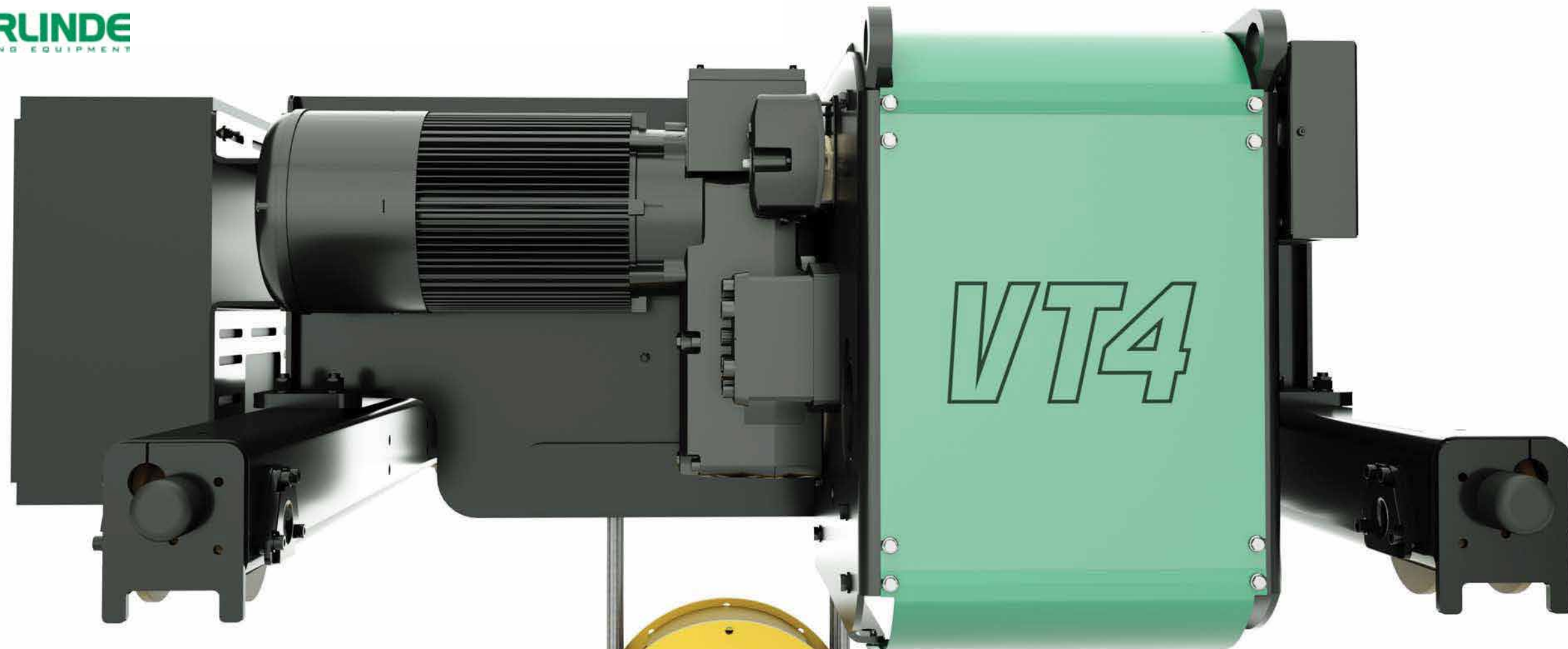
**Surface treatment.** 2- component epoxy paint with 120 µ for greater protection.

### Hoisting drum

There is a special patent for drum assembly and drum rotation without ball bearings.

**Advantage:** this prevents grease and steel particles from falling into the motor.



## Savings

**Hoisting motor.** 60 % operating factor and tropicalised as a standard for greater longevity.

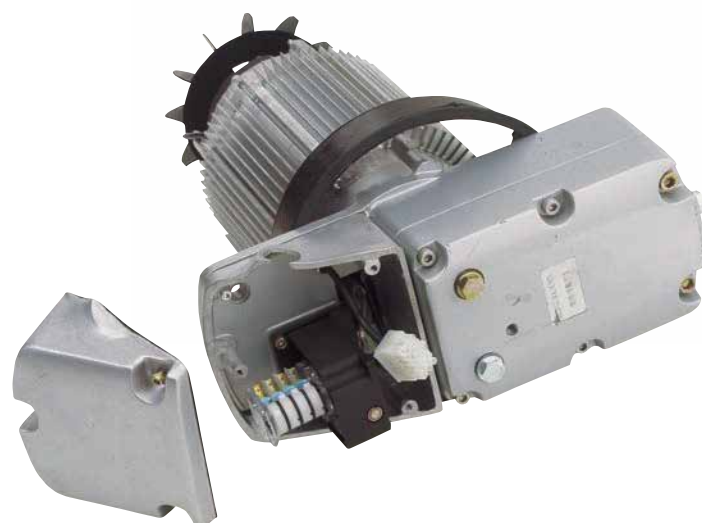
**Travelling motor.** Tropicalised as a standard for greater longevity.

**Pulley block.** The best "C" dimension on the market for optimal use of the size of your buildings and optimal use of work areas.

**Travelling.** Variable travelling speed to reduce wear on steering rollers.

**Load limiter.** As ordered by the directive on "Machines" (required equipment). All EUROBLOC VTs are equipped with a load limiter as a standard (safety measure in the event of hoist overload). For greater longevity.

**Hook and pulley block.** Doesn't take up much space, permanently lubricated rollers, pulleys are in GGG cast iron, very resistant. A high pulley/wire rope diameter ratio gives the wire rope greater longevity.



### Gear limit switches

The limit switch with 4 cams can be accessed on the gear unit and is used for managing the upper and lower limit switches of the hook, switching from low to high speed, and for managing phase reversals.



### MT2

EUROBLOC VT can be equipped with the optional MONITOR 2 (Electronic control of the recording of the hoist's tractive effort states: SWP, time running, starts, overloads, temperature, load, brake, etc.).

### Rope guide

New rope guided system "very high performance" for difficult environments.



## High technology

**Pulley block.** Only a small shift of the pulley block for hoisting (lifting is almost perfectly centred).

**Rope guide.** The guidance system does not get dirty, which allows for use in any type of environment.

**Drum.** A very high wire rope / drum diameter ratio (twice as large as the standard one), which:

- Increases the longevity of the wire rope.
- Reduces the approach data of the hoist.
- Reduces the "C" approach data of the hook.

**Electrical case.** Quite large, it is equipped with the speed variation module as a standard.

**Lifting gearbox.** Direct impulse gearbox unit, helicoid toothed gears, permanently lubricated, detector to prevent pressure overload.

**Optimal positioning of steering rollers.** The 4 steering rollers equally share the load in order to optimise your tracks.





Options

- Non standard rail width.
- Special rail gauge.
- Higher travelling speed.
- Radio remote control.
- Travelling limit switch.
- Derailment catches on double girder trolley.
- Boogies trolley (only with HPN).
- Missing phase control.
- Monitor 2 (MT2).
- 2 or 3 steps overload device.
- Overload device temporization.
- Optical and audible warning connected to overload limit switch.
- Non standard main voltage.
- Rain cover.
- Klaxon on pendant box.
- Explosion proof and / or spark proof version.
- Load indication device.
- Motors thermal protection.
- Class H motors.
- Heating device on motor.
- Stainless steel hoist electrical cubicle
- IP 55 or IP 65.
- CSA electrical control.
- Hook operated upper limit switches.
- Ramshorn hook.
- Additional brake.
- Lifting variable speed.
- Crash protection with electronic cell.



Standards and hoisting regulations

**CE directive.** Since 129 December 2009, the European Machinery Directive (2006/42/EC) applies to the sale and assembly of all new machines marketed from 2010. The new decree is complementary to the former Directive, made up of 600 standards issued in 1995. That directive obliges that machine constructors ensure that their machinery complies with certain regulations, standards, national legislations and technical specifications.

**F.E.M.** European lifting equipment association.  
**S.W.P.** Safe Working Period. A Safe Working Period is calculated for each electrical hoist unit according to the average operating time of the hoisting equipment, load capacity and class of application. After this period, a general service carried out by the constructor is necessary.

**Class of operation.** According to FEM classification, two fundamental criteria must be taken into account: the type of duty and the class of duty (according to average daily operation time average load).

ISO standard. Classes of operation can also be defined according to ISO grouping (1Am =M4, 2m =M5, 3m =M6, etc.).

**Type of duty.**

- **Light service.** Equipment rarely subject to maximum load and frequently to very little load.
- **Medium service.** Equipment rarely subject to maximum load and frequently to very little load.
- **Heavy service.** Equipment frequently subject to maximum load and frequently to medium load.
- **Very heavy service.** Equipment frequently subject to maximum or near maximum load.

| Average daily operating time (hours) |   |    | ≤0,5       | ≤1  | ≤2   | ≤4   | ≤8   | ≤16  |      |    |    |    |    |    |
|--------------------------------------|---|----|------------|-----|------|------|------|------|------|----|----|----|----|----|
| Class of duty                        |   |    | V0,25      | T2  | V0,5 | T3   | V1   | T4   | V2   | T5 | V3 | T6 | V4 | T7 |
| Type of service                      | 1 | L1 | Light      |     |      | 1Bm  | M3   | 1Am  | M4   | 2m | M5 | V4 | M6 |    |
|                                      | 2 | L2 | Medium     |     | 1Bm  | M3   | 1Am  | M4   | 2m   | M5 | 3m | M6 |    |    |
|                                      | 3 | L3 | Heavy      | 1Bm | M3   | 1Am  | M4   | 2m   | M5   | 3m | M6 |    |    |    |
|                                      | 4 | L4 | Very heavy | 1Am | M4   | 2m   | M5   | 3m   | M6   |    |    |    |    |    |
| Group                                |   |    |            |     |      | 1Bm  | M3   | 1Am  | M4   | 2m | M5 | 3m | M6 |    |
| Duty factor*                         |   |    |            |     |      | 25 % | 30 % | 40 % | 50 % |    |    |    |    |    |
| Number of star starts per hour       |   |    |            |     |      | 150  | 180  | 240  | 300  |    |    |    |    |    |

■ FEM 9511 standards classification. ■ ISO standards classification.  
\* Duty factor in % =  $\frac{\text{Hoisting time} + \text{lowering time}}{\text{Hoisting time} + \text{idle time} + \text{lowering time} + \text{idle time}} \times 100$

| Hoist codification | Load (FEM/kg) |              |        | H.O.L. (m)                            | Lifting speeds (m/mn) | Trolleys |          |     |                       |      |     |
|--------------------|---------------|--------------|--------|---------------------------------------|-----------------------|----------|----------|-----|-----------------------|------|-----|
|                    | 1Am           | 2m           | 3m     |                                       |                       | Fixed    | Monorail |     | Double girder trolley |      |     |
|                    |               |              |        |                                       |                       |          | HPR      | HPN | High                  | Med. | Low |
| VT10211--N P1      |               | 1 000        | 800    | 12                                    | 10 / 1,6              | •        | •        | •   | •                     | •    |     |
| VT10211--N P2      |               | 1 600        | 1 250  | 12 - 19                               | 10 / 1,6              | •        | •        | •   | •                     | •    |     |
| VT10211--R P2      |               | 1 600        | 1 250  | 12 - 19                               | 12,5 / 2              | •        | •        | •   | •                     | •    |     |
| VT10411--N P1      |               | 2 000        | 1 600  | 6 - 9,5                               | 5 / 0,8               | •        | •        | •   | •                     | •    |     |
| VT10411--N P2      |               | 3 200        | 2 500  | 6 - 9,5                               | 5 / 0,8               | •        | •        | •   | •                     | •    |     |
| VT10411--R P2      |               | 3 200        | 2 500  | 6 - 9,5                               | 6,3 / 1               | •        | •        | •   | •                     | •    |     |
| VT20211--N P3      |               | 2 500        | 2 000  | 12 - 18 - 24 - 30*                    | 10 / 1,6              | •        | •        | •   | •                     | •    |     |
| VT20211--R P4      |               | 2 500        | 2 000  | 12 - 18 - 24 - 30*                    | 16 / 2,6              | •        | •        | •   | •                     | •    |     |
| VT20211--L P3      | 3 200         |              |        | 12 - 18 - 24 - 30*                    | 8 / 1,3               | •        | •        | •   | •                     | •    |     |
| VT20411--N P3      |               | 5 000        | 4 000  | 6 - 9 - 12 - 15*                      | 5 / 0,8               | •        | •        | •   | •                     | •    |     |
| VT20411--R P4      |               | 5 000        | 4 000  | 6 - 9 - 12 - 15*                      | 8 / 1,3               | •        | •        | •   | •                     | •    |     |
| VT20411--L P3      | 6 300         |              |        | 6 - 9 - 12 - 15*                      | 4 / 0,7               | •        | •        | •   | •                     | •    |     |
| VT20611--N P3      |               | 7 500        |        | 6 - 8 - 10                            | 3,2 / 0,5             | •        | •        | •   | •                     | •    |     |
| VT20611--R P4      |               | 7 500        |        | 6 - 8 - 10                            | 5 / 0,8               | •        | •        | •   | •                     | •    |     |
| VT20811--N P3      | 10 000        | 8 000        |        | 4,5 - 6 - 7,5                         | 2,5 / 0,4             | •        | •        | •   | •                     | •    |     |
| VT20811--R P4      | 10 000        | 8 000        |        | 4,5 - 6 - 7,5                         | 4 / 0,7               | •        | •        | •   | •                     | •    |     |
| VT30211--N P5      |               | 5 000        | 4 000  | 18 - 24 - 32 - 40*                    | 10 / 1,6              | •        | •        | •   | •                     | •    |     |
| VT30211--R P6      |               | 5 000        | 4 000  | 18 - 24 - 32 - 40*                    | 16 / 2,6              | •        | •        | •   | •                     | •    |     |
| VT30211--L P5      | 6 300         |              |        | 18 - 24 - 32 - 40*                    | 8 / 1,3               | •        | •        | •   | •                     | •    |     |
| VT30411--N P5      |               | 10 000       | 8 000  | 9 - 12 - 16 - 20*                     | 5 / 0,8               | •        | •        | •   | •                     | •    |     |
| VT30411--R P6      |               | 10 000       | 8 000  | 9 - 12 - 16 - 20*                     | 8 / 1,3               | •        | •        | •   | •                     | •    |     |
| VT30411--L P5      | 12 500        |              |        | 9 - 12 - 16 - 20*                     | 4 / 0,7               | •        | •        | •   | •                     | •    |     |
| VT30611--N P5      |               | 15 000       |        | 4,5 - 6 - 8 - 10                      | 3,2 / 0,5             | •        | •        | •   | •                     | •    |     |
| VT30611--R P6      |               | 15 000       |        | 4,5 - 6 - 8 - 10                      | 5 / 0,8               | •        | •        | •   | •                     | •    |     |
| VT30811--N P5      | 20 000        | 16 000       |        | 4,5 - 6 - 8 - 10                      | 2,5 / 0,4             | •        | •        | •   | •                     | •    |     |
| VT30811--R P6      | 20 000        | 16 000       |        | 4,5 - 6 - 8 - 10                      | 4 / 0,7               | •        | •        | •   | •                     | •    |     |
| VT30421--N P5      |               | 5 000        | 4 000  | 10 - 14 - 19 - 26 - 35 - 47           | 10 / 1,6              | •        | •        | •   | •                     | •    |     |
| VT30421--R P6      |               | 5 000        | 4 000  | 10 - 14 - 19 - 26 - 35 - 47           | 16 / 2,6              | •        | •        | •   | •                     | •    |     |
| VT30821--N P5      | 10 000        | 8 000        |        | 5 - 7 - 9,5 - 13 - 17,5 - 23,5        | 5 / 0,8               | •        | •        | •   | •                     | •    |     |
| VT30821--R P6      | 10 000        | 8 000        |        | 5 - 7 - 9,5 - 13 - 17,5 - 23,5        | 8 / 1,3               | •        | •        | •   | •                     | •    |     |
| VT31221--N P5      |               | 15 000       | 12 000 | 4,5 - 6,5 - 8,5 - 11,5 - 15,5         | 3,2 / 0,5             | •        | •        | •   | •                     | •    |     |
| VT31221--R P6      |               | 15 000       | 12 000 | 4,5 - 6,5 - 8,5 - 11,5 - 15,5         | 5 / 0,8               | •        | •        | •   | •                     | •    |     |
| VT31621--N P5      | 20 000        | 16 000       |        | 4,5 - 6,5 - 8,5 - 11,5                | 2,5 / 0,4             | •        | •        | •   | •                     | •    |     |
| VT31621--R P6      | 20 000        | 16 000       |        | 4,5 - 6,5 - 8,5 - 11,5                | 4 / 0,7               | •        | •        | •   | •                     | •    |     |
| VT40211--L P6      | 10 000        | 8 000        | 6 300  | 16,4 - 22 - 28,6 - 37                 | 8 / 1,3               | •        | •        | •   | •                     | •    |     |
| VT40211--N P6      |               | 8 000        | 6 300  | 16,4 - 22 - 28,6 - 37                 | 10 / 1,6              | •        | •        | •   | •                     | •    |     |
| VT40211--R P7      | 10 000        |              |        | 16,4 - 22 - 28,6 - 37                 | 10 / 1,6              | •        | •        | •   | •                     | •    |     |
| VT40211--R P7      |               | 8 000        | 6 300  | 16,4 - 22 - 28,6 - 37                 | 12,5 / 2              | •        | •        | •   | •                     | •    |     |
| VT40411--L P6      | 20 000        | 16 000       | 12 500 | 8,2 - 11 - 14,3 - 18,5 - 23,8         | 4 / 0,6               | •        | •        | •   | •                     | •    |     |
| VT40411--N P6      |               | 16 000       | 12 500 | 8,2 - 11 - 14,3 - 18,5 - 23,8         | 5 / 0,8               | •        | •        | •   | •                     | •    |     |
| VT40411--R P7      | 20 000        |              |        | 8,2 - 11 - 14,3 - 18,5 - 23,8         | 5 / 0,8               | •        | •        | •   | •                     | •    |     |
| VT40411--R P7      |               | 16 000       | 12 500 | 8,2 - 11 - 14,3 - 18,5 - 23,8         | 6,3 / 1               | •        | •        | •   | •                     | •    |     |
| VT40611--L P6      | 30 000        | 25 000       |        | 5,5 - 7,3 - 9,5 - 12,3 - 15,9         | 2,5 / 0,4             | •        | •        | •   | •                     | •    |     |
| VT40611--N P6      |               | 25 000       |        | 5,5 - 7,3 - 9,5 - 12,3 - 15,9         | 3,2 / 0,5             | •        | •        | •   | •                     | •    |     |
| VT40611--R P7      | 30 000        |              |        | 5,5 - 7,3 - 9,5 - 12,3 - 15,9         | 3,2 / 0,5             | •        | •        | •   | •                     | •    |     |
| VT40611--R P7      |               | 25 000       |        | 5,5 - 7,3 - 9,5 - 12,3 - 15,9         | 4 / 0,6               | •        | •        | •   | •                     | •    |     |
| VT40811--L P6      | 40 000        |              |        | 5,8 - 7,2 - 9,3 - 11,9                | 2 / 0,3               | •        | •        | •   | •                     | •    |     |
| VT40811--N P7      | 40 000        |              |        | 5,8 - 7,2 - 9,3 - 11,9                | 2,5 / 0,4             | •        | •        | •   | •                     | •    |     |
| VT41011--N P7      |               | 18m / 50 000 |        | 5,8 - 7,2 - 9,3 - 11,9                | 2 / 0,3               | •        | •        | •   | •                     | •    |     |
| VT40421--L P6      | 10 000        | 8 000        | 6 300  | 20 - 25,7 - 33                        | 8 / 1,3               | •        | •        | •   | •                     | •    |     |
| VT40421--N P6      |               | 8 000        | 6 300  | 20 - 25,7 - 33                        | 10 / 1,6              | •        | •        | •   | •                     | •    |     |
| VT40421--R P7      | 10 000        |              |        | 20 - 25,7 - 33                        | 10 / 1,6              | •        | •        | •   | •                     | •    |     |
| VT40421--R P7      |               | 8 000        | 6 300  | 20 - 25,7 - 33                        | 12,5 / 2              | •        | •        | •   | •                     | •    |     |
| VT40821--L P6      | 20 000        | 16 000       | 12 500 | 10 - 12,8 - 16,5 - 21,2 - 27,9 - 33,7 | 4 / 0,6               | •        | •        | •   | •                     | •    |     |
| VT40821--N P6      |               | 16 000       | 12 500 | 10 - 12,8 - 16,5 - 21,2 - 27,9 - 33,7 | 5 / 0,8               | •        | •        | •   | •                     | •    |     |
| VT40821--R P7      | 20 000        |              |        | 10 - 12,8 - 16,5 - 21,2 - 27,9 - 33,7 | 5 / 0,8               | •        | •        | •   | •                     | •    |     |
| VT40821--R P7      |               | 16 000       | 12 500 | 10 - 12,8 - 16,5 - 21,2 - 27,9 - 33,7 | 6,3 / 1               | •        | •        | •   | •                     | •    |     |
| VT41221--L P6      | 30 000        | 25 000       |        | 6,6 - 8,5 - 11 - 14,1 - 18,6 - 22,4   | 2,5 / 0,4             | •        | •        | •   | •                     | •    |     |
| VT41221--N P6      |               | 25 000       |        | 6,6 - 8,5 - 11 - 14,1 - 18,6 - 22,4   | 3,2 / 0,5             | •        | •        | •   | •                     | •    |     |
| VT41221--R P7      | 30 000        |              |        | 6,6 - 8,5 - 11 - 14,1 - 18,6 - 22,4   | 3,2 / 0,5             | •        | •        | •   | •                     | •    |     |
| VT41221--R P7      |               | 25 000       |        | 6,6 - 8,5 - 11 - 14,1 - 18,6 - 22,4   | 4 / 0,6               | •        | •        | •   | •                     | •    |     |
| VT41621--L P6      | 40 000        |              |        | 6,4 - 8,2 - 10,6 - 13,9 - 16,8        | 2 / 0,3               | •        | •        | •   | •                     | •    |     |
| VT41621--N P7      | 40 000        |              |        | 6,4 - 8,2 - 10,6 - 13,9 - 16,8        | 2,5 / 0,4             | •        | •        | •   | •                     | •    |     |
| VT42021--N P7      |               | 18m / 50 000 |        | 6,6 - 8,5 - 11,1                      | 2 / 0,3               | •        | •        | •   | •                     | •    |     |
| VT50421--          | 20 000        | 16 000       | 12 500 | 4,5 - 6,7 - 10,1 - 13,5               | **                    | •        | •        | •   | •                     | •    |     |
| VT50821--          | 40 000        | 32 000       | 25 000 | 6,2 - 8,2 - 10,9 - 14,4               | **                    | •        | •        | •   | •                     | •    |     |
| VT51221--          | 60 000        | 50 000       |        | 5,9 - 7,7 - 10 - 13,2                 | **                    | •        | •        | •   | •                     | •    |     |
| VT51621--          | 80 000        |              |        | 5,8 - 7,5 - 9,9 - 12                  | **                    | •        | •        | •   | •                     | •    |     |

\*Not available in HPR version.

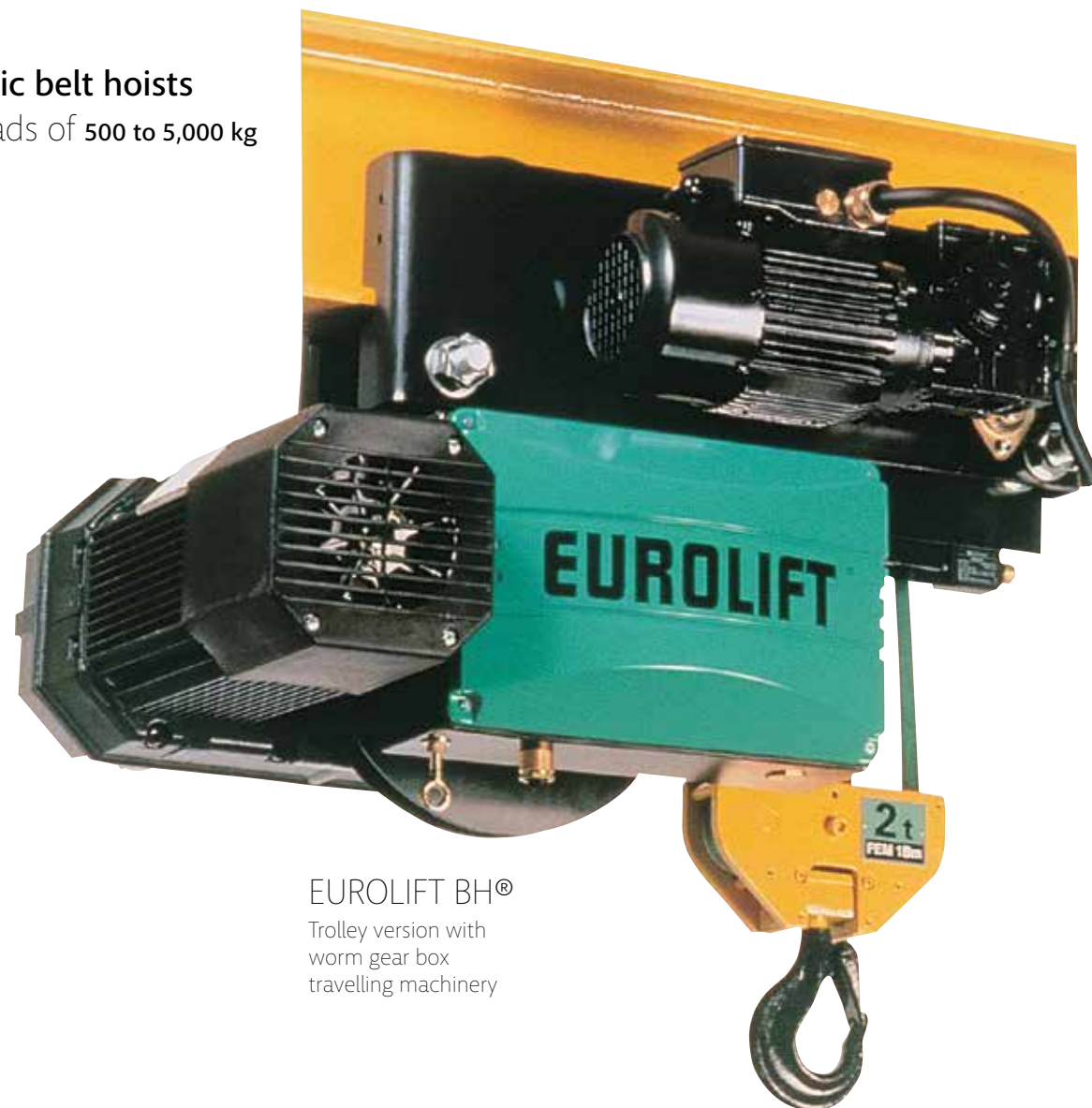
\*\*Consult us.





## EUROLIFT BH® 12

Electric belt hoists  
for loads of 500 to 5,000 kg



### EUROLIFT BH®

Trolley version with  
worm gear box  
travelling machinery

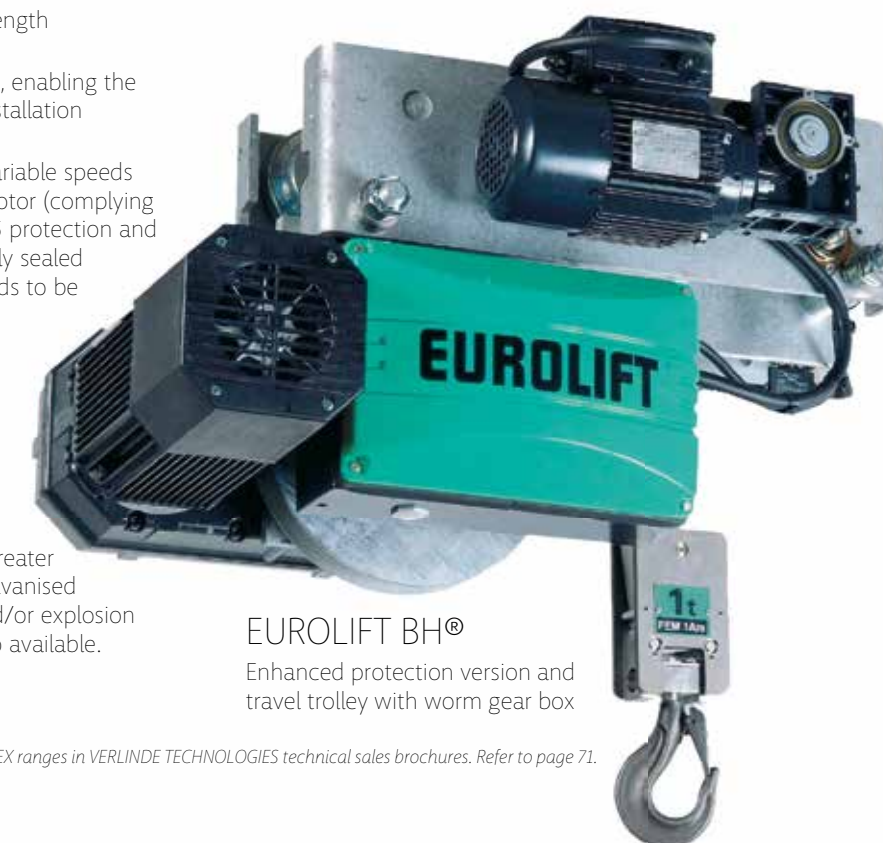


The EUROLIFT BH electric belt hoist meets your needs for hoisting power with the strictest levels of cleanliness. The EUROLIFT BH is a hoist complying with EC European standards, offering you the lifting power and robustness of a product designed for industrial duty combined with 100% clean operation to meet your most stringent requirements with regard to hygiene, handling of foodstuffs and chemical products and "white room" conditions,...



### Technical characteristics

- Anticorrosion product with high strength rot-proof belt.
- Exceptionally little loss of headroom, enabling the EUROLIFT BH to adapt to all your installation configurations.
- Lift motor with two mechanically variable speeds and two speed travel movement motor (complying with standard EC 34.1/IEC 34.2, IP 55 protection and insulation F) combined with perfectly sealed reduction gearing enabling your loads to be shifted silently with great precision.
- A high security belt guide, electric hoisting limit switch and electrical load limiter as standard equipment, ensuring you, as user, maximum safety in every situation.
- Variable speed travel motor for precise positioning of loads.
- An option of this lifting unit offers greater protection with stainless steel or galvanised elements and an EX spark proof and/or explosion proof version (ATEX standard) is also available.



### EUROLIFT BH®

Enhanced protection version and  
travel trolley with worm gear box



Refer to sales information on our EX ATEX ranges in VERLINDE TECHNOLOGIES technical sales brochures. Refer to page 71.



**VERLINDE** TIRLIFT®  
LIFTING EQUIPMENT



TIRLIFT®  
Long version TL

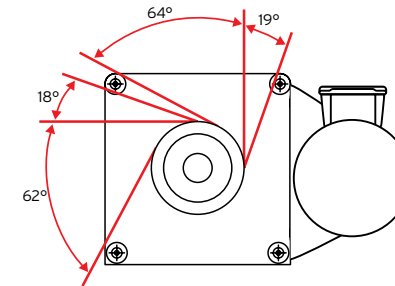
**Electric belt hoists**  
for loads of 125 to 990 kg



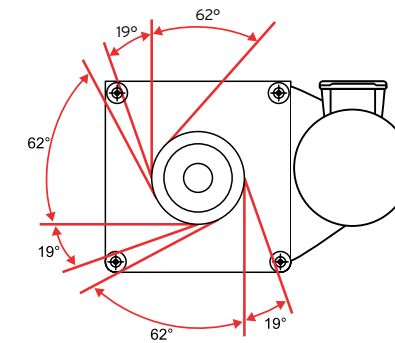
TIRLIFT®  
Short version TC

This line of all-purpose electric winches for lifting and traction adapt perfectly to all your needs (wide load range, numerous options). They are designed for the lifting of loads of 125 kg to 990 kg. Compliance with the EC directive concerning machines.

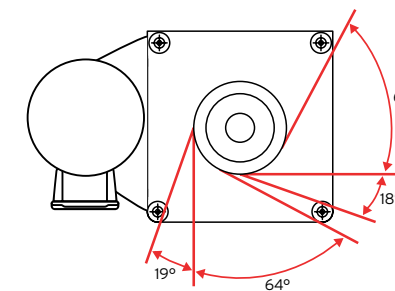
Winch positions and rope outlets



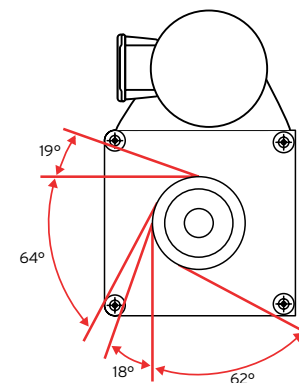
• **Outlet A**  
Foot mounted.  
Rope outlet on left side (rope fixed to right of drum, on gear side).



• **Outlet B**  
Foot mounted.  
Rope outlet on right side (rope fixed to left of drum, on bearing side).



• **Outlet C**  
Version mounted on ceiling.  
Rope outlet on right side (rope fixed to right of drum, on gear side).



• **Outlet D**  
Rope outlet on left side (rope fixed to left of drum, on bearing side).



Technical characteristics

The TIRLIFT type TL and TC electric winches offer as standard:

- A drum designed for 5 to 7 mm wire ropes depending on loads.
- IP55 type protection of the switchgear (cabinet and motor).
- A wide range of lift braking motors complying with class F insulation.
- A frame of modular and open-ended design, permitting for instance multiple cable exit directions from the drum.
- Tri-phase or single phase available.









---

Jib Cranes,  
Gantry Cranes  
and Accessories

175





## EUROSYSTEM® ST

### Overhead handling systems

for loads of 60 to 2,000 kg

The ideal solution for moving light loads. The EUROSYSTEM overhead handling system adapts perfectly to your site development or production process needs, offering a great many configurations.

The EUROSYSTEM can take the form of a monorail, roller paths, single-girder overhead travelling cranes, double girder overhead travelling cranes, single or complex circuit systems, with points for changing the direction of travel, or a multi-direction turntable.

### Unquestionable advantages

- The loads are easy to handle, thanks to an excellent rolling coefficient.
- The load on the bearing structure is kept to a minimum through the pendular design of the system.
- Maintenance is practically zero.
- Installations are pleasing to the eye.
- Great flexibility.
- Minimum loss of headroom.
- Many different solutions for securing the system, adaptable to any structure (I-beams, wood, concrete,...).
- Installation and anchoring simply by bolting.

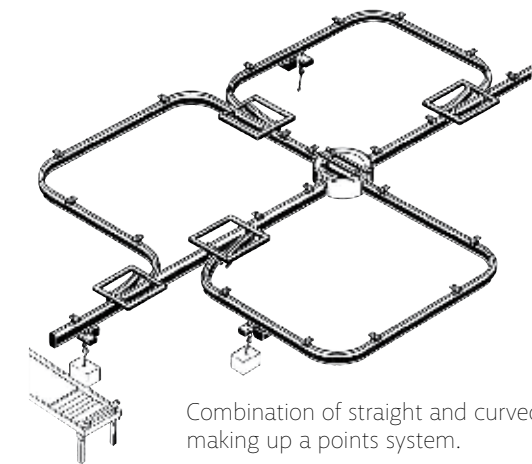
### Technical characteristics

An graded range of hollow sections providing excellent headroom. The EUROSYSTEM consists of three different models, the use of which is determined by the load capacity and distance between the suspension points:

- UKA 20: maximum capacity 250 kg
- UKA 30: maximum capacity 1,000 kg
- UKA 40: maximum capacity 2,000 kg



- **Suspended or embedded single girder travelling crane.**  
Load capacity: 125 to 1,600 kg  
A practical solution for handling requirements over large areas.



Combination of straight and curved sections making up a points system.

- **Suspended or embedded double girder travelling crane.**

Load capacity: 125 to 2,000 kg  
For greater loads and reaches, a EUROSYSTEM twin-beam model can also be provided, to meet your lifting and handling requirement.







## EUROSYSTEM® ALU



Aluminium hollow  
profile overhead  
handling system  
for loads of 60 to 2,000 kg

### Technical characteristics

A graded range of 4 sizes of profile.  
As for steel sections, the selection of the model will depend on the load capacity and the distance between the suspension points.

- AL06, 6.5 kg/m, up to 320 kg.
- AL08, 8 kg/m, up to 500 kg.
- AL06, 10.6 kg/m, up to 2,000 kg.
- AL06, 14.5 kg/m, up to 2,000 kg.



The Aluminium Eurosystem represents a new generation of hollow profile handling systems. This innovative solution presents the combined advantages of conventional steel and aluminium hollow profile.

### Advantages of aluminium

- **ERGONOMIC.** The lightness of the rails provides easy, effortless manipulation by the user even with heavy and unwieldy loads.
- **PRECISE.** Precision is ensured by top quality manufacturing and smooth manoeuvring.
- **ANTI-CORROSIVE TREATMENT.** The profile aluminium is anodized outside and inside.
- **ECONOMICAL.** By the reduced volume and simplification of the bearing structures, by the rapidity of assembly.
- **NEW TECHNOLOGY.** The profile was made possible by the latest cold extrusion engineering innovations and optimisation of structures.
- **PRACTICAL.** The profile is compatible with all ITEM standardised accessories.
- **LONG LIFE SPAN.** The remarkable resistance to wear is due to the anodizing treatment and to the roller material.
- **SAFETY.** The profile is guaranteed weldless.
- **NOISELESS.** The very low noise level of operation is due to the great smoothness of the rolling surface.



- **Suspended or embedded single girder travelling crane.**  
Load capacity up to 2,000 kg.  
Can be embedded to optimise lifting height.



### Options available

- Integrated electrical power supply.
- Transfer system.
- Powered travelling and/or traversing trolleys.
- Parallel power supply in profile with integrated lead.



- **Suspended or embedded double girder travelling crane.**  
Load capacity up to 2,000 kg.  
For large spans and highest loads. 3-dimensional surface coating.  
Limited overall height.





Made-to-measure configurations

- Wall-mounted (secured to the wall or a mast post)

Triangular design



**VATS**  
Boom in EUROSISTEM ST type hollow profile.



**VAT**  
IPE section boom



**VATAL**  
Boom in EUROSISTEM ALU type hollow profile.



Inverted design



**VAI**  
IPE section boom

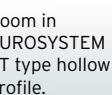


- Column mounted partially slewable

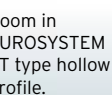
Triangular design



**VFTS**  
Boom in EUROSISTEM ST type hollow profile.



**VFT**  
IPE section boom



**VFTAL**  
Boom in EUROSISTEM ALU type hollow profile.



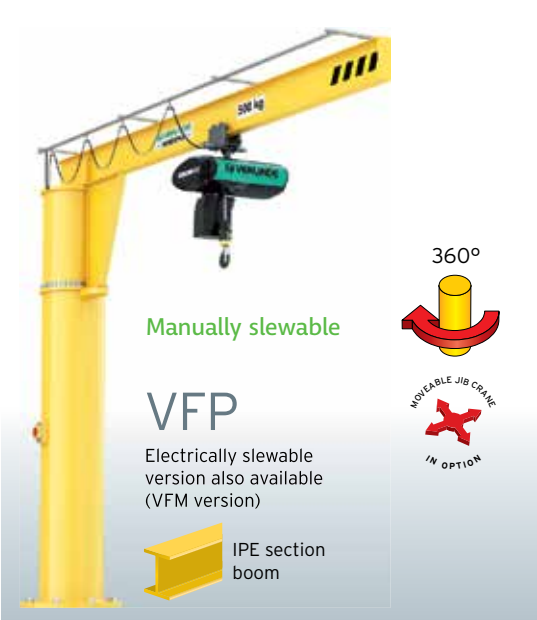
Inverted design



**VFI**  
IPE section boom



- Column mounted 360° slewable



Manually slewable

**VFP**

Electrically slewable version also available (VFM version)

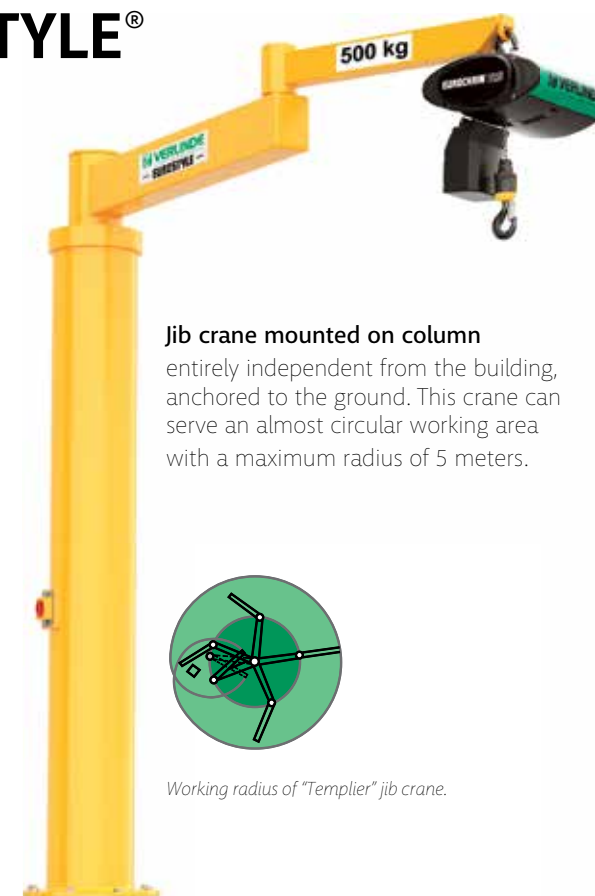
IPE section boom



“Templier” type manual jib cranes with articulated arms

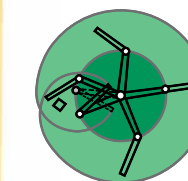
VERLINDE articulated crane is designed for handling loads of 50 to 1,000 kg with ease, taking up very little space in an almost circular area. Practically all the working zones afford access to the hoisting tackle mounted at the tip of the boom.

The articulated arm enables obstacles to be avoided.



Jib crane mounted on column

entirely independent from the building, anchored to the ground. This crane can serve an almost circular working area with a maximum radius of 5 meters.



Working radius of “Templier” jib crane.

Technical characteristics

- All-steel design in compliance with DIN 15018 standards.
- Service temperature: -10° to +40° C.
- IP54 switchgear.
- Presentation: shot-peened frame, primer coat and glossy yellow topcoat.

The characteristics of all our cranes (overall dimensions, weight, boom length and foundations) are indicated in our technical sheets.



Jib crane mounted on bracket

(secured to a wall or mast post). This crane serves an almost circular working area with a radius of 5 meters.

Jib crane mounted on roof

(secured to a ceiling or members of the structural frame of the building). This crane can serve an almost circular working area with a radius of 5 meters.







## EUROSTYLE® H<sub>2</sub>O RANGE

Aluminium and galvanized jib cranes for water treatment systems.



Ideal for operations in used water treatment stations or at shore sites, EUROSTYLE H<sub>2</sub>O jib cranes are easily transported and manoeuvred by one person.

Furthermore, they are dismantlable to be moved from one base to another.

EUROSTYLE  
ALUMINIUM  
VEFP

360°



### Technical characteristics

- Aluminium dismantlable jib crane, 360° slewable.
- Span adjustable to radius of 1.50 m.
- 300 or 500 kg load range (according to model).
- 3 or 4 elements make up the jib crane, very fast assembly.
- Can be easily moved about and stored using the carry bag(s).
- Slewing system is highly flexible by means of the swivel mounted in bearings.
- RAL powder-coated on anodized surface (very robust and shock-resistant).
- 2 different heights available by means of 2 extension pieces of different lengths (delivered as standard).
- Supplied with 2 stainless steel shackles for securing lifting block or accessory.

### Options available

- Manual VHR type load lifting hoist.
- Manual winch system as standard for load lifting.
- Wide range of aluminium, stainless steel or galvanized bases to be fixed to floor or wall.
- Mounting hardware kit.
- Jib crane frame riser with different heights.



EUROSTYLE  
GALVA VEFPT

360°



### Technical characteristics

- Galvanized steel dismantlable jib crane, 360° slewable.
- Span: loads vary with span from 0.5 to 1.5 m.
- Headroom beneath hook: 2.88 to 3.26m.
- Load capacity: 500 kg.
- Electrogalvanized swivel mounted on greased ball bearings.
- Loaded slewing effort: less than 200 N.
- 2 tubular, hinged and removable manoeuvring handles.
- Manual lever hoist with galvanized chain to orientate the jib arm.
- Nylon return pulley.
- Flat synthetic fibre strap guy.
- Each element is fitted with a synthetic fibre carry handle.
- Storage case in varnished pinewood.

### Options available

- Manual VHR type load lifting hoist.
- Manual load lifting winch.
- Wide range of aluminium, stainless steel or galvanized bases to be fixed to floor or wall.
- Mounting hardware kit.
- Paint uaranteed 6 years.
- ATEX jib crane or in STAINLESS STEEL.



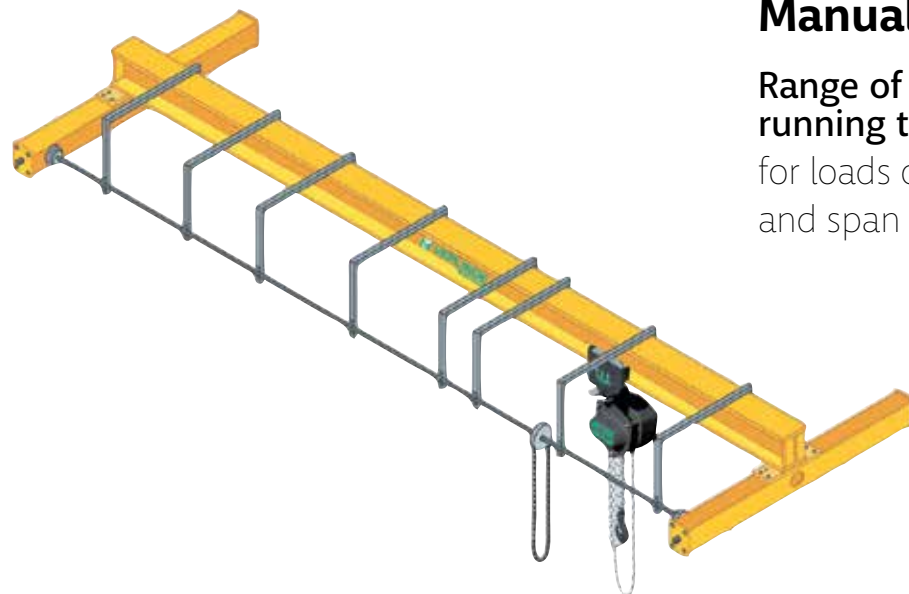




## GANTRY CRANES

### Manual Cranes

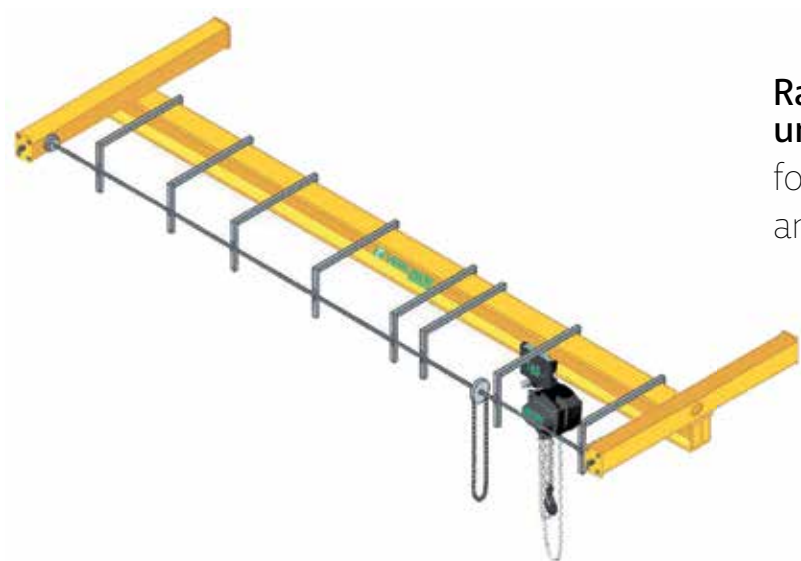
Range of hand operated top-running travelling cranes for loads of 250 to 10,000 kg and span of up 18 meters



#### Technical characteristics

- Complete crane delivered ready to erect. Frame designed to group 2m requirements. The runway beam consists of an IPN, IPE, HEA or HEB profile, depending on the load and span, two travel movement support girders equipped with steel wheels and buffer. Finish in RAL 1028 glycerophthalic lacquer.
- Delivered with assembly and dimension drawings.
- An option for electrification of this type of crane is also available.

VERLINDE's manual travelling cranes program provides access to a comprehensive travelling system for your hand operated or electrically powered lifting devices.



Range of hand operated underslung cranes for loads of 250 to 6,300 kg and span of up 16 meters

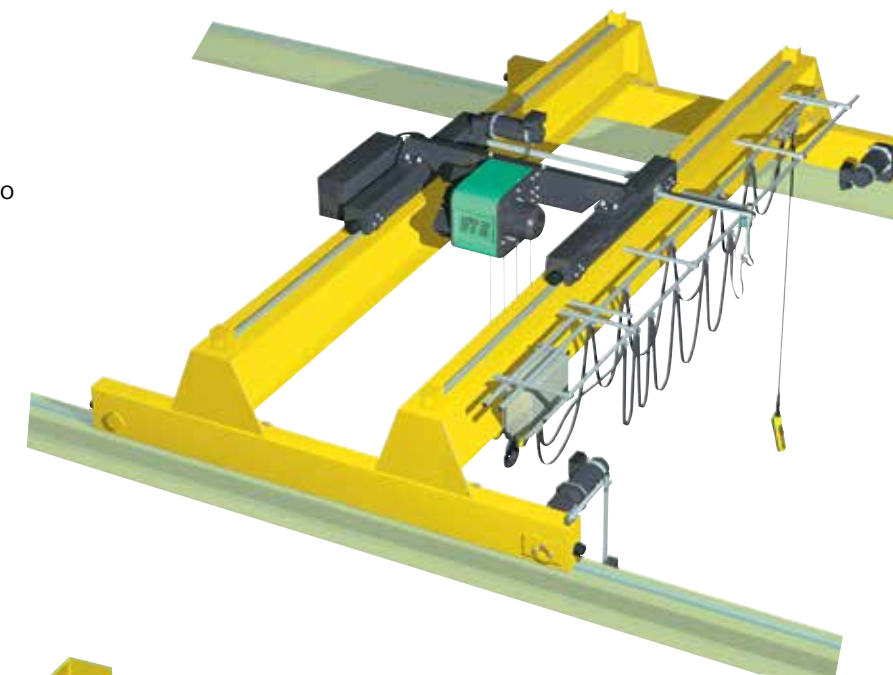
#### Technical characteristics

- Complete crane delivered ready to erect. Frame designed to group 2m requirements. The runway beam consists of an IPN, IPE, HEA or HEB profile, depending on the load and span with two travel movement support girders. Finish in RAL 1028 glycerophthalic lacquer. Delivered with assembly and dimension drawings.
- End carriage fitted with steel wheels and buffer.
- An option for electrification of this type of crane is also available.

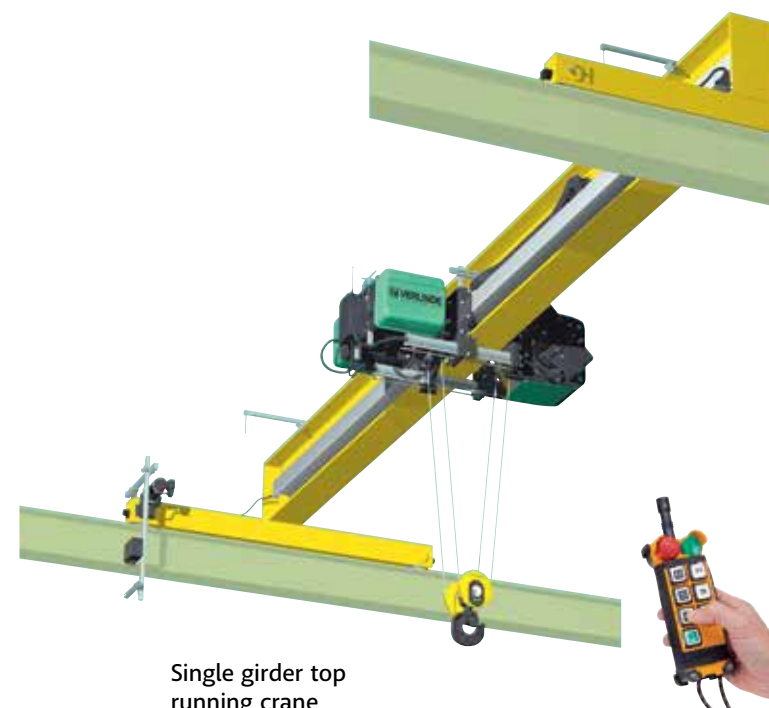


Europont is a network of French, Belgium and Netherlands cranes manufacturers. Range of EUROPONT VERLINDE travelling cranes breaks down into 7 versions and two types (conventional power supply line or cable-carrying chain):

- Single girder top-running overhead travelling crane with electric chain or wire rope hoist.
- Single girder underslung overhead travelling crane in profile with electric chain or wire rope hoist.
- Double girder top-running overhead travelling crane with electric wire rope hoist.



Double girder top running crane



Single girder top running crane



Underslung travelling crane single girder





## COMPOSANTS +



**Top-running and underslung end carriage.**  
 • Wheels are also available in spark-proof version.

### Travelling crane components

The range of VERLINDE components for electrically-power overhead travelling cranes offers you a complete high performance hoisting, travelling and traverse system.

#### General power supply line.

- Conventional type of power line.
- Cable holder chain power line.



#### Travelling roller unit.

This geared travelling unit is designed for top-running end carriage.



#### Electric cabinet.

- Sealed (IP55) steel cabinet.
- Main isolating switch, actuatable from outside.
- Compliant with standard NF 52070.
- Available in explosion-proof version.



#### Travelling motor gear box.

- 2 standard travel speeds: many other speed possibilities.
- Motor-reduction set available in explosion-proof version.



#### Movable box.

- Movable along the length of the crane as it travels, and independent from the hoisting device,



#### Options available

- Radio remote-control system.
- VARIATOR: frequency inverter system for variable speed on lifting and travelling motions.
- Electronic system for monitoring the statuses of the hoist and crane.
- Zone lighting.
- Luminous or audio warning system indicating that the load is in motion.
- Digital display of load on the crane, hook or pushbutton box.

#### Load gripping system

- (lifting beam, clamp and clamshell)



## EUROMOTE®

### Radio remote control system for hoists and travelling cranes

The EUROMOTE remote control systems have been specially designed for use with the EUROBLOCK and EUROCHAIN hoisting unit and the crane components of VERLINDE.

Adapted to the most severe industrial conditions, the EUROMOTE remote control systems stand out through their ease of use, great flexibility and reliability. They will enable you to improve the productivity of your operators and the safety of lifting manoeuvres and achieve productivity gains and shorter down-times.

### Micromote®



### Euromote H®



### Digimote®







**Aluminium hollow profile overhead handling system**  
for loads of 250 to 5,000 kg

VGI gantry crane



With this line of VERLINDE independent manual gantries, maintenance services, assembly teams and any artisan mechanic will be able to carry out mounting, dismounting operations, and position parts or assemblies. This line of standard gantries is designed to receive all types of hoisting device. The VERLINDE gantry can be equipped with manual or electrically-powered chain tackle.

**Technical characteristics**

- The extreme mobility and stability on all surfaces provided by means of four caster wheels fitted with ball bearings on the shafts and king pins. These wheels formed from acetyl resin have excellent shock behaviour and ability to withstand attack by chemicals.
- The raceway is a weld-fabricated IPE profile designed to accommodate a lifting and traversing movement device, with two traversing breast-pieces. The unit is finished in RAL 1028 polyurethane lacquer. Fully dismantlable, the VERLINDE independent gantries adapt to your need to make best use of workshop space.
- The gantry is delivered disassembled, together with its galvanised boltwork and takes little time to assemble and commission.
- A 3-piece dismantled weld fabricated package.
- The gantries can be moved loaded on a smooth, clean floor.

**Load capacity**

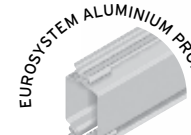
|               | 250 kg | 500 kg | 1000 kg | 1600 kg | 2000 kg | 3200 kg | 5000 kg |
|---------------|--------|--------|---------|---------|---------|---------|---------|
| > VGI gantry  |        |        |         |         |         |         |         |
| > VGPS gantry |        |        |         |         |         |         |         |
| > VGPA gantry |        |        |         |         |         |         |         |



VGPS gantry crane  
EUROSYSTEM TYPE STEEL hollow profile

**Technical characteristics**

- The characteristics of these gantries are identical to those of the standard profile model except for the following:
- The raceway of these VERLINDE workshop gantries consists of a EUROSYSTEM hollow profile in steel or aluminium (depending on model).
  - The gantry is delivered with a manual hoist-bearing EUROSYSTEM type trolley.
  - These workshop gantries are mounted on caster wheels in white polyamide.
  - The gantry cannot be shifted under load.
  - On the aluminium gantry version:  
Legs can be folded for handling.  
Lift height and span can be adjusted by an operator alone.



VGPA gantry crane  
EUROSYSTEM type aluminium hollow profile





**PAL®** Range of steel and aluminium lifting beams

for loads of 125 to 10,000 kg



**PAL P2R ALU**  
with central hanging and  
2 adjustable lifting points.



**PAL P2R**  
with central hanging and  
2 adjustable lifting points.



Technical characteristics

- Rupture safety factor: 5.
- The PAL line is manufactured to standard NFE 52210 and classed category FEM 5.
- No load bearing welds.
- Anti-rust treatment and RAL1028 glycerine paint finish.
- Standard equipment: bow shackles, reel hooks and safety latches.
- EC certificate of compliance.
- User manual.

Options available

- "Y" type models with 3 hoisting points or
- "X" type with 4 hoisting points available on request.
- Galvanized lifting beams.
- Special lifting beams with fork gripping system for pallets.
- Lifting beams for Big Bag system.
- Special aluminium lifting beams for light hoists.

| Model    | Capacity (kg) | Span (m) |
|----------|---------------|----------|
| P2F      | 1000 to 10000 | 1 to 6   |
| P2R      | 1000 to 10000 | 0,5 to 6 |
| P4F      | 1000 to 10000 | 1 to 4   |
| P4R      | 1000 to 10000 | 1 to 4   |
| P2F ALU  | 125 to 2000   | 1 to 6   |
| P2R ALU  | 125 to 2000   | 1 to 6   |
| P4HF ALU | 125 to 2000   | 1 to 4   |
| P4HR ALU | 125 to 2000   | 1 to 4   |



**PAL P4F**  
"H" type central hanging and 4  
permanent lifting points.



**PAL P4R**  
"H" type with central  
hanging and 4  
adjustable lifting points.

Technical characteristics

- Fitted with 2 articulated forged safety swivel hooks.
- Tear-resistant eyelet for use with synthetic slings, cables, etc.
- Rustproof paint with high-strength yellow RAL 1028 finishing.
- Safety coefficient: 4
- No load-bearing welding.
- Manufacture in accordance with standard NFE 52210.
- Group: FEM5.
- Hooks adjusted by means of upper handles (for the adjustable spreaders only).
- No 100 mm adjustment as standard (for the adjustable spreaders only).
- Hoisting speed = maximum 16 m/mn.
- Delivered with instructions for use and maintenance, EC certificate of conformity.



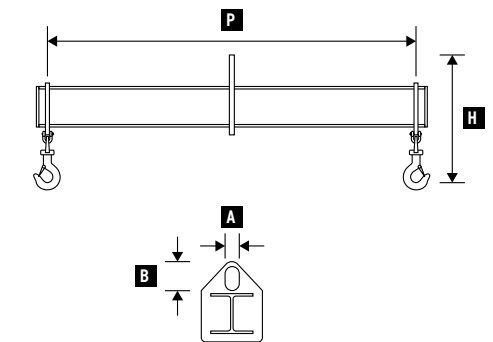
Articulated swivel hooks with  
forged safety latches.

**PAL P2F**

for loads of 1,000 to 10,000 kg

Axial cord lifting beam with 2 fixed lifting points

| Load (T) | A x B (mm) | Span in metres (P) |     |     |     |     |     |     |
|----------|------------|--------------------|-----|-----|-----|-----|-----|-----|
|          |            | 1                  | 2   | 3   | 4   | 5   | 6   |     |
| 1 T      | 60 x 80    | Height "H" (mm)    | 320 | 340 | 360 | 360 | 380 | 380 |
|          |            | Weight (kg)        | 32  | 59  | 96  | 122 | 176 | 208 |
| 2 T      | 80 x 120   | Height "H" (mm)    | 380 | 400 | 420 | 440 | 460 | 480 |
|          |            | Weight (kg)        | 39  | 72  | 115 | 170 | 240 | 324 |
| 3 T      | 100 x 180  | Height "H" (mm)    | 480 | 500 | 540 | 560 | 580 | 600 |
|          |            | Weight (kg)        | 56  | 94  | 163 | 234 | 326 | 432 |
| 4 T      | 100 x 180  | Height "H" (mm)    | 480 | 520 | 560 | 580 | 600 | 620 |
|          |            | Weight (kg)        | 62  | 112 | 190 | 274 | 375 | 495 |
| 5 T      | 100 x 180  | Height "H" (mm)    | 540 | 580 | 620 | 640 | 660 | 700 |
|          |            | Weight (kg)        | 69  | 126 | 216 | 306 | 420 | 597 |
| 6 T      | 100 x 180  | Height "H" (mm)    | 540 | 600 | 640 | 660 | 700 | 700 |
|          |            | Weight (kg)        | 80  | 151 | 250 | 355 | 516 | 608 |
| 8 T      | 100 x 180  | Height "H" (mm)    | 600 | 660 | 700 | 740 | 740 | 840 |
|          |            | Weight (kg)        | 93  | 176 | 288 | 431 | 524 | 616 |
| 10 T     | 100 x 180  | Height "H" (mm)    | 620 | 680 | 740 | 740 | 740 | 790 |
|          |            | Weight (kg)        | 107 | 198 | 345 | 437 | 530 | 798 |

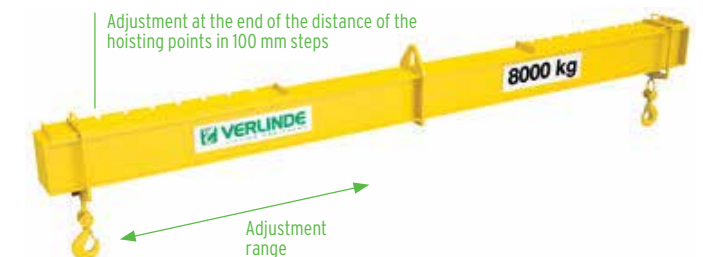


**PAL P2R**

for loads of 1,000 to 10,000 kg

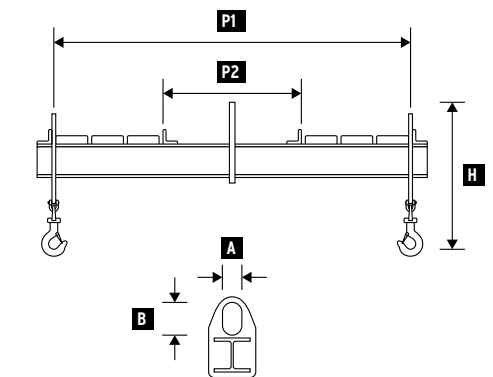
Axial cord lifting beam with 2 adjustable lifting points

| Load (T) | A x B (mm) | Span in metres (P) |       |       |       |       |       |     |
|----------|------------|--------------------|-------|-------|-------|-------|-------|-----|
|          |            | 1 / 0,5            | 2 / 1 | 3 / 1 | 4 / 2 | 5 / 3 | 6 / 4 |     |
| 1 T      | 60 x 80    | Height "H" (mm)    | 490   | 510   | 530   | 530   | 550   | 550 |
|          |            | Weight (kg)        | 38    | 64    | 101   | 127   | 181   | 213 |
| 2 T      | 80 x 120   | Height "H" (mm)    | 450   | 470   | 490   | 510   | 530   | 550 |
|          |            | Weight (kg)        | 44    | 77    | 120   | 175   | 245   | 329 |
| 3 T      | 100 x 180  | Height "H" (mm)    | 560   | 580   | 620   | 640   | 660   | 680 |
|          |            | Weight (kg)        | 66    | 104   | 173   | 244   | 336   | 442 |
| 4 T      | 100 x 180  | Height "H" (mm)    | 610   | 650   | 690   | 710   | 730   | 750 |
|          |            | Weight (kg)        | 72    | 122   | 200   | 284   | 385   | 505 |
| 5 T      | 100 x 180  | Height "H" (mm)    | 630   | 670   | 710   | 730   | 750   | 790 |
|          |            | Weight (kg)        | 79    | 136   | 226   | 316   | 430   | 607 |
| 6 T      | 100 x 180  | Height "H" (mm)    | 630   | 690   | 730   | 750   | 790   | 790 |
|          |            | Weight (kg)        | 95    | 166   | 265   | 370   | 531   | 623 |
| 8 T      | 100 x 180  | Height "H" (mm)    | 710   | 770   | 810   | 850   | 850   | 850 |
|          |            | Weight (kg)        | 113   | 196   | 308   | 451   | 544   | 636 |
| 10 T     | 100 x 180  | Height "H" (mm)    | 730   | 790   | 850   | 850   | 850   | 900 |
|          |            | Weight (kg)        | 127   | 218   | 365   | 457   | 550   | 818 |



Adjustment at the end of the distance of the  
hoisting points in 100 mm steps

Adjustment  
range





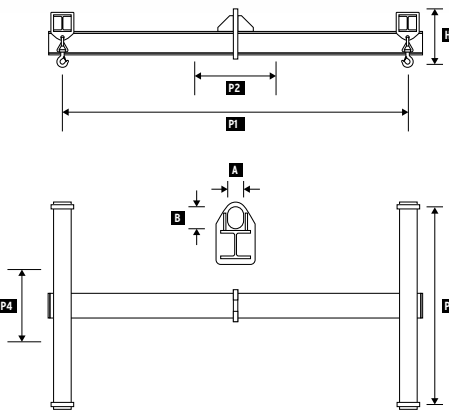
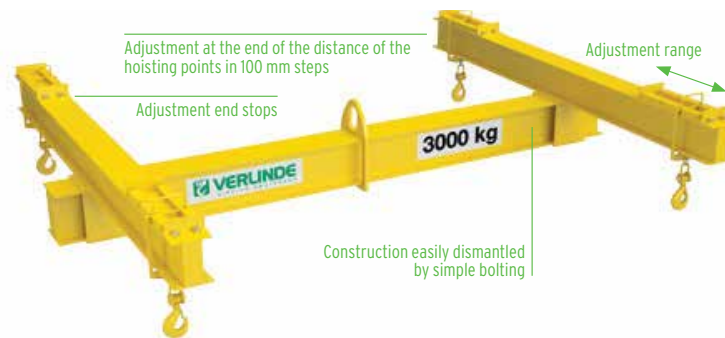
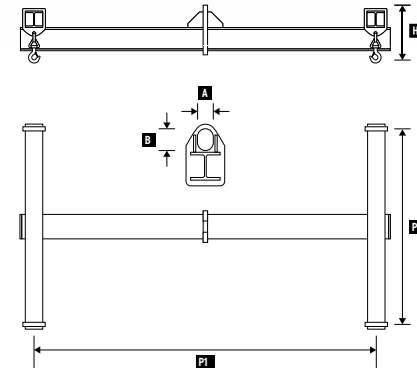
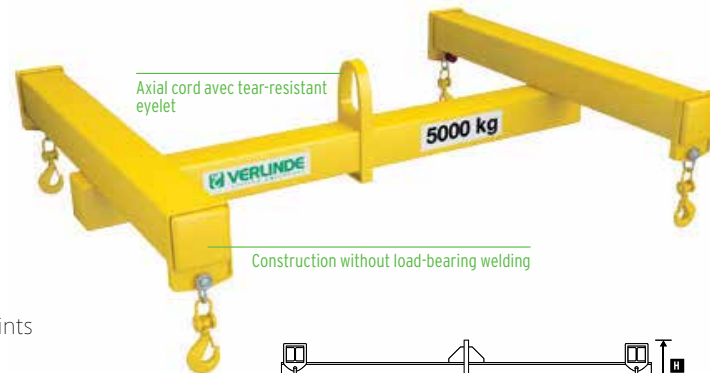
## PAL® Range of steel and aluminium lifting beams

### PAL P4HF

for loads of 1,000 to 10,000 kg

"H" type axial cord lifting beam with fixed 4 lifting points

| Load (T) | A x B (mm) | Span in metres (P1) / Base in metres (P2) |       |       |       |       |       |     |
|----------|------------|---|-------|-------|-------|-------|-------|-----|
|          |            | 1 / 1                                     | 2 / 1 | 3 / 1 | 3 / 2 | 4 / 1 | 4 / 2 |     |
| 1 T      | 60 x 80    | Height "H" (mm)                           | 240   | 240   | 240   | 240   | 240   | 240 |
|          |            | Weight (kg)                               | 78    | 105   | 142   | 177   | 168   | 203 |
| 2 T      | 80 x 120   | Height "H" (mm)                           | 270   | 270   | 270   | 270   | 270   | 270 |
|          |            | Weight (kg)                               | 85    | 118   | 161   | 211   | 216   | 266 |
| 3 T      | 100 x 180  | Height "H" (mm)                           | 350   | 350   | 350   | 350   | 350   | 350 |
|          |            | Weight (kg)                               | 103   | 141   | 210   | 284   | 281   | 355 |
| 4 T      | 100 x 180  | Height "H" (mm)                           | 350   | 350   | 350   | 350   | 350   | 350 |
|          |            | Weight (kg)                               | 117   | 167   | 245   | 311   | 329   | 395 |
| 5 T      | 100 x 180  | Height "H" (mm)                           | 390   | 390   | 390   | 390   | 390   | 390 |
|          |            | Weight (kg)                               | 125   | 182   | 272   | 360   | 362   | 450 |
| 6 T      | 100 x 180  | Hauteur "H" (mm)                          | 390   | 390   | 390   | 390   | 390   | 390 |
|          |            | Weight (kg)                               | 148   | 219   | 318   | 394   | 423   | 500 |
| 8 T      | 100 x 180  | Height "H" (mm)                           | 430   | 430   | 430   | 430   | 430   | 430 |
|          |            | Weight (kg)                               | 163   | 246   | 358   | 457   | 501   | 600 |
| 10 T     | 100 x 180  | Height "H" (mm)                           | 430   | 430   | 430   | 430   | 430   | 430 |
|          |            | Weight (kg)                               | 189   | 280   | 427   | 541   | 519   | 633 |



### PAL P4HR

for loads of 1,000 to 10,000 kg

"H" type Lifting beam axial cord with 4 adjustable lifting points

| Load (T) | A x B (mm) | Span in metres maxi/mini (P1/P2) / Base in metres maxi/mini (P3/P4) |           |           |         |           |         |     |
|----------|------------|---|-----------|-----------|---------|-----------|---------|-----|
|          |            | 1/0,5/0,5/0,5   | 2/1/1/0,5 | 3/1/1/0,5 | 3/1/2/1 | 4/2/1/0,5 | 4/2/2/1 |     |
| 1 T      | 60 x 80    | Height "H" (mm)   | 290       | 290       | 290     | 290       | 290     | 290 |
|          |            | Weight (kg)   | 98        | 125       | 162     | 197       | 188     | 223 |
| 2 T      | 80 x 120   | Height "H" (mm)   | 320       | 320       | 320     | 320       | 320     | 320 |
|          |            | Weight (kg)   | 105       | 138       | 181     | 231       | 236     | 286 |
| 3 T      | 100 x 180  | Height "H" (mm)   | 400       | 400       | 400     | 400       | 400     | 400 |
|          |            | Weight (kg)   | 123       | 161       | 230     | 304       | 301     | 375 |
| 4 T      | 100 x 180  | Height "H" (mm)   | 400       | 400       | 400     | 400       | 400     | 400 |
|          |            | Weight (kg)   | 147       | 197       | 275     | 341       | 359     | 425 |
| 5 T      | 100 x 180  | Height "H" (mm)   | 440       | 440       | 440     | 440       | 440     | 440 |
|          |            | Weight (kg)   | 155       | 212       | 302     | 390       | 392     | 480 |
| 6 T      | 100 x 180  | Height "H" (mm)   | 440       | 440       | 440     | 440       | 440     | 440 |
|          |            | Weight (kg)   | 178       | 249       | 348     | 424       | 453     | 550 |
| 8 T      | 100 x 180  | Height "H" (mm)   | 480       | 480       | 480     | 480       | 480     | 480 |
|          |            | Weight (kg)   | 193       | 276       | 388     | 487       | 531     | 630 |
| 10 T     | 100 x 180  | Height "H" (mm)   | 480       | 480       | 480     | 480       | 480     | 480 |
|          |            | Weight (kg)   | 219       | 310       | 457     | 531       | 549     | 673 |

#### Options available

- Greater load capacities available on request.
- 3 Type «Y» models with 3 lifting points, or type «X» with 4 lifting points are also available on request.
- Lifting beams for big bag.Special lifting beams.
- Galvanised lifting beams.
- Special lifting beams with pick-up fork for pallets.

#### Technical characteristics

- Fitted with swivel hooks with forged safety clips.
- Tear-resistant eyelet for use with synthetic slings, cables, etc.
- Anodised aluminium profile, rust-proof.
- Safety coefficient: 4.
- No load-bearing welding.
- Manufacture in accordance with standard NFE 52210.
- FEM5 group.
- Hooks adjustable by movable spindles for adjustable beams only).
- Adjustable by step of 100 mm for adjustable beams only).
- Lifting speed: 16 m/mn maxi.
- Delivered with instructions for use and maintenance, EC certificate of conformity

#### Advantages in aluminium

- The aluminium profile is anodised and is provides protection against corrosion
- This aluminium profile is compatible with all the standardised ITEM accessories

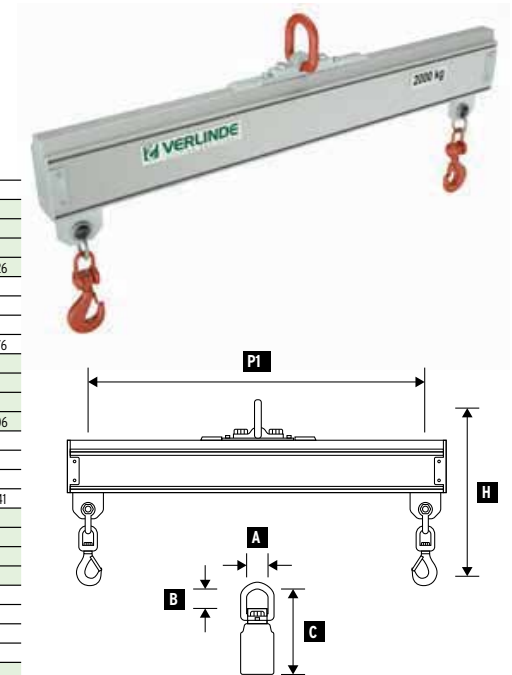
- Overall, the aluminium lifting beam is lighter than its steel equivalent, this makes it possible to optimise the chain hoist's capacity for lifting loads

### PAL P2F ALU

for loads of 125 to 2,000 kg

Axial cord aluminium lifting beam with 2 fixed lifting points

| Load (kg) | Total span in metres      |           |           |           |           |           |           |
|-----------|---------------------------|-----------|-----------|-----------|-----------|-----------|-----------|
|           | 1                         | 2         | 3         | 4         | 5         | 6         |           |
| 125       | Length between hooks (P1) | 900       | 1900      | 2900      | 3900      | 4900      | 5900      |
|           | Weight (kg)               | 16        | 22        | 29        | 35        | 42        | 48        |
|           | Headroom (H)              | 454       | 454       | 454       | 454       | 454       | 454       |
| 250       | Dim. A x B x C            | 56x53x226 | 56x53x226 | 56x53x226 | 56x53x226 | 56x53x226 | 56x53x226 |
|           | Length between hooks (P1) | 900       | 1900      | 2900      | 3900      | 4900      | 5900      |
|           | Weight (kg)               | 16        | 22        | 29        | 35        | 42        | 48        |
| 500       | Headroom (H)              | 454       | 454       | 454       | 454       | 454       | 454       |
|           | Dim. A x B x C            | 56x53x226 | 56x53x226 | 56x53x226 | 56x53x226 | 56x53x226 | 56x53x276 |
|           | Length between hooks (P1) | 900       | 1900      | 2900      | 3900      | 4900      | 5900      |
| 750       | Weight (kg)               | 16        | 22        | 36        | 44        | 53        | 74        |
|           | Headroom (H)              | 454       | 454       | 454       | 454       | 454       | 504       |
|           | Dim. A x B x C            | 56x53x226 | 56x53x276 | 56x53x276 | 56x53x306 | 56x53x306 | 56x53x306 |
| 1000      | Length between hooks (P1) | 900       | 1900      | 2900      | 3900      | 4900      | 5900      |
|           | Weight (kg)               | 21        | 31        | 42        | 68        | 83        | -         |
|           | Headroom (H)              | 535       | 535       | 535       | 569       | 569       | -         |
| 1600      | Dim. A x B x C            | 56x53x306 | 56x53x306 | 56x53x341 | 56x53x341 | 56x53x341 | -         |
|           | Length between hooks (P1) | 900       | 1900      | 2900      | 3900      | 4900      | -         |
|           | Weight (kg)               | 21        | 31        | 54        | -         | -         | -         |
| 2000      | Headroom (H)              | 535       | 569       | -         | -         | -         | -         |
|           | Dim. A x B x C            | 56x53x306 | 56x53x341 | -         | -         | -         | -         |
|           | Length between hooks (P1) | 900       | 1900      | -         | -         | -         | -         |

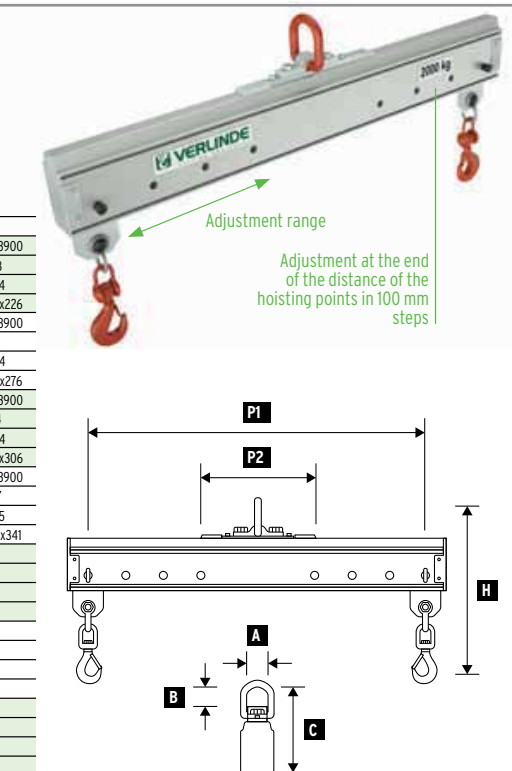


### PAL P2R ALU

for loads of 125 to 2,000 kg

Aluminium axial cord lifting beam with 2 adjustable lifting points

| Load (kg) | Total span in metres                   |           |           |           |           |           |           |
|-----------|--|-----------|-----------|-----------|-----------|-----------|-----------|
|           | 1                                      | 2         | 3         | 4         | 5         | 6         |           |
| 125       | Length and width between hooks (P1/P2) | 900/300   | 1900/900  | 2900/900  | 3900/1900 | 4900/2900 | 5900/3900 |
|           | Weight (kg)                            | 16        | 22        | 29        | 35        | 42        | 48        |
|           | Headroom (H)                           | 454       | 454       | 454       | 454       | 454       | 454       |
| 250       | Dim. A x B x C                         | 56x53x226 | 56x53x226 | 56x53x226 | 56x53x226 | 56x53x226 | 56x53x226 |
|           | Length and width between hooks (P1/P2) | 900/300   | 1900/900  | 2900/900  | 3900/1900 | 4900/2900 | 5900/3900 |
|           | Weight (kg)                            | 16        | 22        | 29        | 35        | 42        | 48        |
| 500       | Headroom (H)                           | 454       | 454       | 454       | 454       | 454       | 504       |
|           | Dim. A x B x C                         | 56x53x226 | 56x53x226 | 56x53x276 | 56x53x276 | 56x53x276 | 56x53x306 |
|           | Length and width between hooks (P1/P2) | 900/300   | 1900/900  | 2900/900  | 3900/1900 | 4900/2900 | 5900/3900 |
| 750       | Weight (kg)                            | 16        | 27        | 36        | 52        | 83        | 97        |
|           | Headroom (H)                           | 454       | 454       | 504       | 504       | 504       | 535       |
|           | Dim. A x B x C                         | 56x53x226 | 56x53x276 | 56x53x276 | 56x53x306 | 56x53x306 | 56x53x341 |
| 1000      | Length and width between hooks (P1/P2) | 900/300   | 1900/900  | 2900/900  | 3900/1900 | 4900/2900 | -         |
|           | Weight (kg)                            | 21        | 31        | 42        | 68        | 83        | -         |
|           | Headroom (H)                           | 535       | 535       | 535       | 569       | 569       | -         |
| 1600      | Dim. A x B x C                         | 56x53x306 | 56x53x306 | 56x53x341 | 56x53x341 | 56x53x341 | -         |
|           | Length and width between hooks (P1/P2) | 900/300   | 1900/900  | 2900/900  | 3900/1900 | 4900/2900 | -         |
|           | Weight (kg)                            | 21        | 31        | 54        | -         | -         | -         |
| 2000      | Headroom (H)                           | 535       | 569       | -         | -         | -         | -         |
|           | Dim. A x B x C                         | 56x53x306 | 56x53x341 | -         | -         | -         | -         |
|           | Length and width between hooks (P1/P2) | 900/300   | 1900/900  | -         | -         | -         | -         |







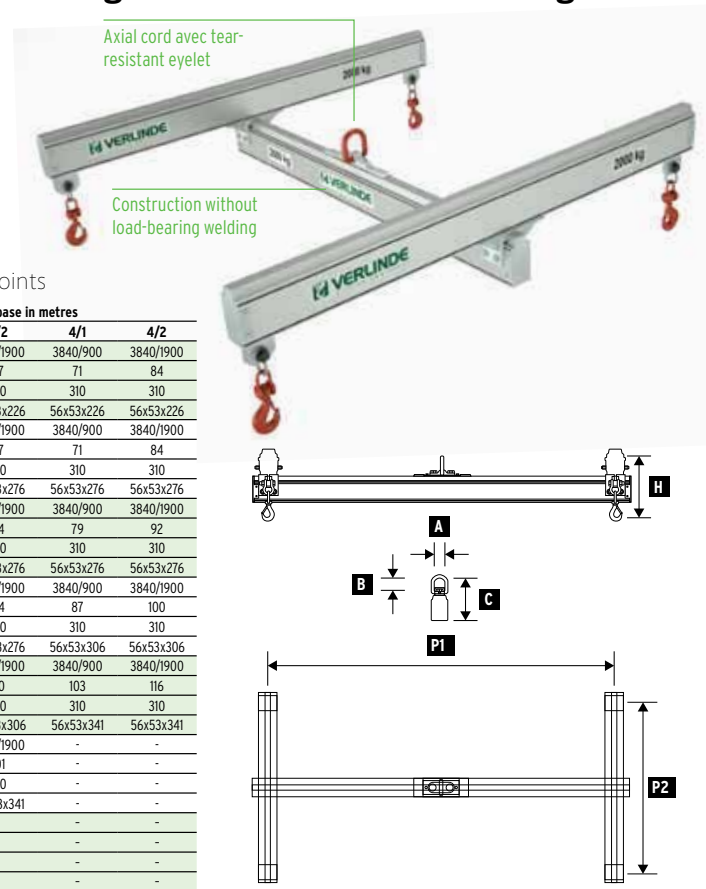
**PAL®** Range of steel and aluminium lifting beams

**PAL P4HF ALU**

for loads of 125 to 2,000 kg

Aluminium axial cord lifting beam with **fixed** 4 lifting points

| Load (kg) | Total span in metres / Total base in metres |           |           |           |           |           |           |
|-----------|---|-----------|-----------|-----------|-----------|-----------|-----------|
|           | 1/1   | 2/1       | 3/1       | 3/2       | 4/1       | 4/2       |           |
| 125       | Maxi/mini length between hooks (P1/P2)      | 840/900   | 1840/900  | 2840/900  | 2840/1900 | 3840/900  | 3840/1900 |
|           | Weight (kg)                                 | 51        | 58        | 64        | 77        | 71        | 84        |
|           | Headroom (H)                                | 310       | 310       | 310       | 310       | 310       | 310       |
|           | Dim. A x B x C                              | 56x53x226 | 56x53x226 | 56x53x226 | 56x53x226 | 56x53x226 | 56x53x226 |
| 250       | Maxi/mini length between hooks (P1/P2)      | 840/900   | 1840/900  | 2840/900  | 2840/1900 | 3840/900  | 3840/1900 |
|           | Weight (kg)                                 | 51        | 58        | 64        | 77        | 71        | 84        |
|           | Headroom (H)                                | 310       | 310       | 310       | 310       | 310       | 310       |
|           | Dim. A x B x C                              | 56x53x226 | 56x53x226 | 56x53x276 | 56x53x276 | 56x53x276 | 56x53x276 |
| 500       | Maxi/mini length between hooks (P1/P2)      | 840/900   | 1840/900  | 2840/900  | 2840/1900 | 3840/900  | 3840/1900 |
|           | Weight (kg)                                 | 51        | 58        | 71        | 84        | 79        | 92        |
|           | Hauteur perdue (H)                          | 310       | 310       | 310       | 310       | 310       | 310       |
|           | Dim. A x B x C                              | 56x53x226 | 56x53x226 | 56x53x276 | 56x53x276 | 56x53x276 | 56x53x276 |
| 750       | Maxi/mini length between hooks (P1/P2)      | 840/900   | 1840/900  | 2840/900  | 2840/1900 | 3840/900  | 3840/1900 |
|           | Weight (kg)                                 | 51        | 62        | 71        | 84        | 87        | 100       |
|           | Headroom (H)                                | 310       | 310       | 310       | 310       | 310       | 310       |
|           | Dim. A x B x C                              | 56x53x226 | 56x53x276 | 56x53x276 | 56x53x276 | 56x53x306 | 56x53x306 |
| 1000      | Maxi/mini length between hooks (P1/P2)      | 840/900   | 1840/900  | 2840/900  | 2840/1900 | 3840/900  | 3840/1900 |
|           | Weight (kg)                                 | 55        | 66        | 77        | 90        | 103       | 116       |
|           | Headroom (H)                                | 310       | 310       | 310       | 310       | 310       | 310       |
|           | Dim. A x B x C                              | 56x53x306 | 56x53x306 | 56x53x306 | 56x53x306 | 56x53x341 | 56x53x341 |
| 1600      | Maxi/mini length between hooks (P1/P2)      | 840/900   | 1840/900  | 2840/900  | 2840/1900 | -         | -         |
|           | Weight (kg)                                 | 55        | 66        | 88        | 101       | -         | -         |
|           | Hauteur perdue (H)                          | 310       | 310       | 310       | 310       | -         | -         |
|           | Dim. A x B x C                              | 56x53x306 | 56x53x306 | 56x53x341 | 56x53x341 | -         | -         |
| 2000      | Maxi/mini length between hooks (P1/P2)      | 840/900   | 1840/900  | -         | -         | -         | -         |
|           | Weight (kg)                                 | 64        | 82        | -         | -         | -         | -         |
|           | Headroom (H)                                | 310       | 310       | -         | -         | -         | -         |
|           | Dim. A x B x C                              | 56x53x306 | 56x53x341 | -         | -         | -         | -         |

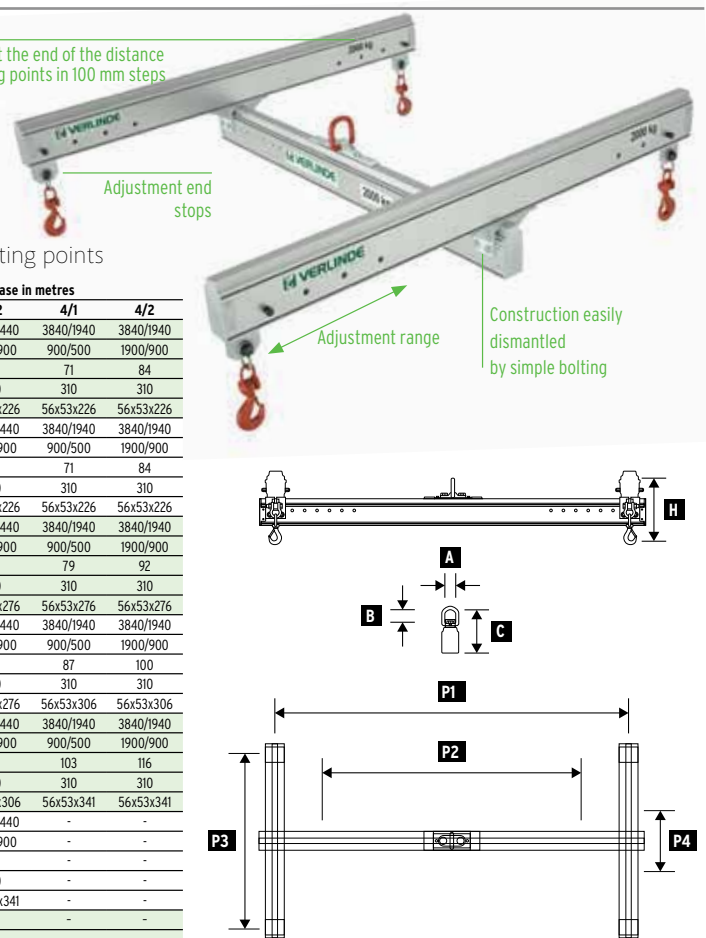


**PAL P4HR ALU**

for loads of 125 to 2,000 kg

Aluminium axial cord lifting beam with 4 **adjustable** lifting points

| Load (kg) | Total span in metres / Total base in metres |         |          |           |           |           |           |
|-----------|---|---------|----------|-----------|-----------|-----------|-----------|
|           | 1/1   | 2/1     | 3/1      | 3/2       | 4/1       | 4/2       |           |
| 125       | Long. maxi/mini between hooks (P1/P2)       | 840/400 | 1840/940 | 2840/1440 | 2840/1440 | 3840/1940 | 3840/1940 |
|           | Maxi/mini width between hooks (P3/P4)       | 900/500 | 900/500  | 900/500   | 1900/900  | 900/500   | 1900/900  |
|           | Weight (kg)                                 | 51      | 58       | 64        | 77        | 71        | 84        |
|           | Headroom (H)                                | 310     | 310      | 310       | 310       | 310       | 310       |
| 250       | Long. maxi/mini between hooks (P1/P2)       | 840/400 | 1840/940 | 2840/1440 | 2840/1440 | 3840/1940 | 3840/1940 |
|           | Maxi/mini width between hooks (P3/P4)       | 900/500 | 900/500  | 900/500   | 1900/900  | 900/500   | 1900/900  |
|           | Weight (kg)                                 | 51      | 58       | 64        | 77        | 71        | 84        |
|           | Headroom (H)                                | 310     | 310      | 310       | 310       | 310       | 310       |
| 500       | Long. maxi/mini between hooks (P1/P2)       | 840/400 | 1840/940 | 2840/1440 | 2840/1440 | 3840/1940 | 3840/1940 |
|           | Maxi/mini width between hooks (P3/P4)       | 900/500 | 900/500  | 900/500   | 1900/900  | 900/500   | 1900/900  |
|           | Weight (kg)                                 | 51      | 58       | 71        | 84        | 79        | 92        |
|           | Headroom (H)                                | 310     | 310      | 310       | 310       | 310       | 310       |
| 750       | Long. maxi/mini between hooks (P1/P2)       | 840/400 | 1840/940 | 2840/1440 | 2840/1440 | 3840/1940 | 3840/1940 |
|           | Maxi/mini width between hooks (P3/P4)       | 900/500 | 900/500  | 900/500   | 1900/900  | 900/500   | 1900/900  |
|           | Weight (kg)                                 | 51      | 62       | 71        | 84        | 87        | 100       |
|           | Headroom (H)                                | 310     | 310      | 310       | 310       | 310       | 310       |
| 1000      | Long. maxi/mini between hooks (P1/P2)       | 840/400 | 1840/940 | 2840/1440 | 2840/1440 | 3840/1940 | 3840/1940 |
|           | Maxi/mini width between hooks (P3/P4)       | 900/500 | 900/500  | 900/500   | 1900/900  | 900/500   | 1900/900  |
|           | Weight (kg)                                 | 55      | 66       | 77        | 90        | 103       | 116       |
|           | Headroom (H)                                | 310     | 310      | 310       | 310       | 310       | 310       |
| 1600      | Long. maxi/mini between hooks (P1/P2)       | 840/440 | 1840/940 | 2840/1440 | 2840/1440 | -         | -         |
|           | Maxi/mini width between hooks (P3/P4)       | 900/500 | 900/500  | 900/500   | 1900/900  | -         | -         |
|           | Weight (kg)                                 | 55      | 66       | 88        | 101       | -         | -         |
|           | Headroom (H)                                | 310     | 310      | 310       | 310       | -         | -         |
| 2000      | Long. maxi/mini between hooks (P1/P2)       | 840/440 | 1840/940 | -         | -         | -         | -         |
|           | Maxi/mini width between hooks (P3/P4)       | 900/500 | 900/500  | -         | -         | -         | -         |
|           | Weight (kg)                                 | 64      | 82       | -         | -         | -         | -         |
|           | Headroom (H)                                | 310     | 310      | -         | -         | -         | -         |



**PEV®**

Electronic force gauges with digital readout

for loads of 200 to 32,000 kg

VERLINDE offers a comprehensive range of compact electronic force gauges fitted with LCD or LED displays showing the load on hook in real time.

Technical characteristics

- Precision is +/- 0,1% of rated capacity.
- Standard functions: overload signal (110% of max. load), calibration.
- Reset, Total, complete deletion (except PEV 1 where "total" and "complete deletion" are options).
- Excellent legibility with large size display (LCD or LED).
- Readings are logged.
- Working temperature -20° to +60° C.
- Protection: IP 55.
- Delivered with 2 shackles and top and bottom mounting hardware.
- Delivered with rechargeable batteries and charger.



Options available

- Large-sized display.
- 25.4 mm digit on 5 LED display.
- Infra-red remote control.
- Carry case.
- Preselection of load.
- Intensive use batteries.
- Stainless steel version of gauge available
- Tropicalisation and IP 65 protection
- Printer integrated in gauge.
- Radio link, Bluetooth or Wifi.







---

Vacuum and Pneumatic  
Lifting Solutions

197

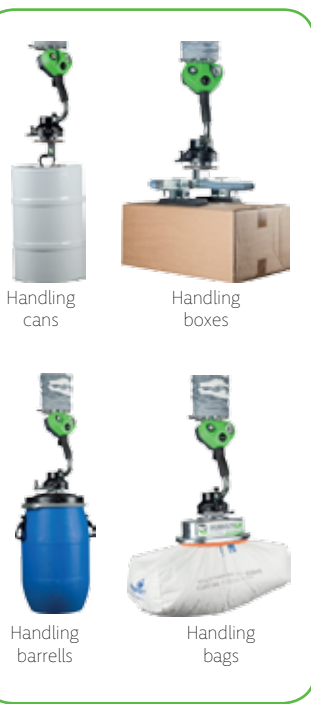


# ERGO Fast

For repetitive and prolonged handling at an ergonomic height, it allows the operator to maintain a significant pace, all the while removing the risk of MSDs.



Also available in stainless steel



Joint allowing for the load to be rotated from horizontal to vertical or the load to be gripped horizontally or vertically



The handle is designed to encourage a full grip. This grip, known as a strong one, allows the load to be moved effortlessly. The operator can feel confident of having a firm grip by the neutral position of the forearm which allows for a greater freedom of movement of his upper limb. There is an automatic lifting system built-in to free the load effortlessly.

As an optional extra, there is the possibility of incorporating the start/ stop control onto the head. This way, the operator no longer needs to move to turn the device on or off.



Built-in automatic lifting system

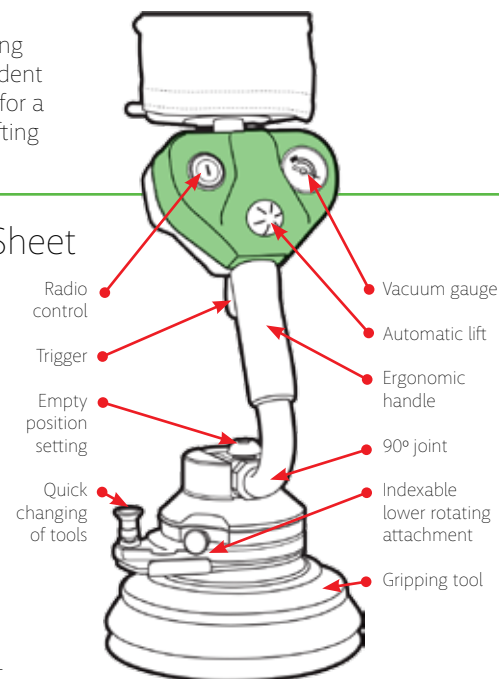
## Technical Specifications Sheet

### Integrated functions:

- Trigger
- Empty position setting
- Vacuum gauge
- Automatic lift
- Ergonomic handle
- Gripping tool
- 90° joint

### Optional functions:

- Radio control
- Quick changing of tools
- Indexable lower rotating attachment



# ERGO Flex

In the case of repetitive and prolonged handling at variable heights, it allows the operator to maintain a significant pace, all the while removing the risk of MSDs.



Also available in stainless steel



The handle has been designed to support the natural movement of the operator's wrist at variable heights, throughout their handling operations. Its modular system also allows it to go from a right to left-handed position and back, one hand triggers the system, the second acts as guidance assistance, which can reassure the operator for delicate, large or hazardous loads.



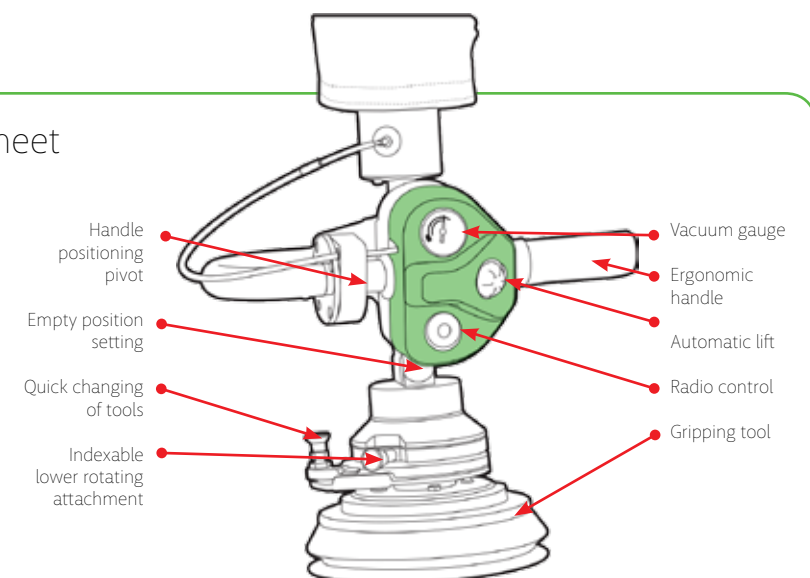
## Technical Specifications Sheet

### Integrated functions:

- Handle positioning pivot
- Empty position setting
- Quick change
- Vacuum gauge
- Ergonomic handle
- Automatic lift
- Gripping tool

### Optional functions:

- Radio control
- Quick changing of tools
- Indexable lower rotating attachment





# ERGO Plus

In the case of repetitive and prolonged handling at significant heights, it allows the operator to maintain a rapid pace, all the while removing the risk of MSDs.



Also available in stainless steel



This handle combines the advantages of the two previous ones. It is better suited to heavy, large or sensitive products. It has been designed so that the operator stays in an ergonomic position during the lowest and highest handling operations alike. The built-in automatic lifting system allows the operator to free the load effortlessly.

As an optional extra, there is the possibility of incorporating the start/stop control onto the head. This way, the operator no longer needs to move to turn the device on or off.



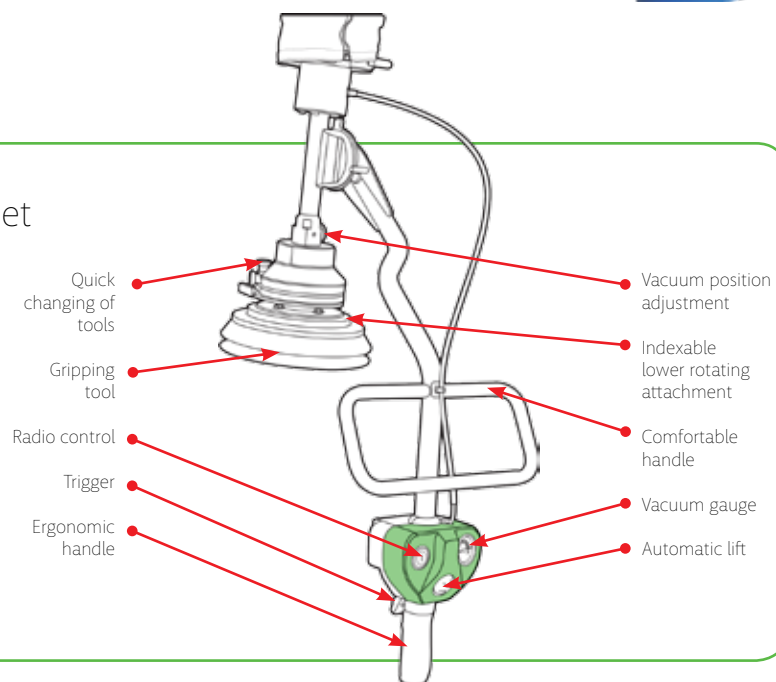
### Technical Specifications Sheet

**Integrated functions:**

- Trigger
- Gripping tool
- Ergonomic handl
- Comfortable handle
- Vacuum gauge
- Automatic lift

**Optional functions:**

- Radio control
- Quick changing of tools
- Indexable lower rotating attachment



# The Supports

The support is an integral part of the MANUT-LM handling assistance solution. By doing no more than defining the lifting equipment, you only respond partially to the issue of seeking ergonomics and removing difficult working conditions in the work station.

The support must be adapted to the vacuum lifting device, but it must also meet the requirements of your environment.

- Do you need to cover a significant working area or feed a machine?
- Do you have low-ceilinged premises or need to get round an obstacle?
- Do you have health and/or safety requirements specific to your business area?
- Do you have the option, or not, of attaching the support to the ground, the wall or a pillar?
- Do you need to be able to move the support?

## Crane Bridges

Made up of two crane runways and a sliding girder, this support is also available as a monorail version. It requires attachment to the building's structural framework or implementation of a structure on the ground. It is available in steel, aluminium or stainless steel.



Also available in stainless steel

### The Advantages:

- Able to cover a significant working area.
- Allows for a more flexible use of the manipulator(s).
- Lets you have several manipulators under a single support.

## Jib cranes with sliding rail

This is a support which requires a significant height available and a good quality floor to attach it (jib crane on a column) or a wall/pillar compatible with the weight of the load and the range of the jib crane (wall jib crane). It is available in steel, stainless steel or with an aluminium rail.



Also available in stainless steel

### The Advantages:

- Light to use
- Range up to 6m over a 260/270° rotation
- Moderate cost

## Articulated jib crane

It is made from 2 articulated arms with the option of creating a vacuum inside. It needs a good quality floor to attach it (jib crane on a column) or a wall/pillar compatible with the weight of the load and the range of the jib crane (wall jib crane). It is available in steel or, depending on the weight, in stainless steel.



Also available in stainless steel

### The Advantages:

- Installation possible in low-ceilinged premises or with an obstacle to get round.
- Range (up to 4m, 270° rotation on the first arm and 320° on the second arm).
- Avoids retention areas in environments with strict hygiene requirements, no air intake tube or rail (exclusive to Manut-LM).





---

Pneumatic Hoists

203



# JDN AIR HOISTS Mini

## The mini series at a glance



## The JDN mini series for general duty

Capacities: 125 kg, 250 kg, 500 kg, 980 kg  
Air pressure: 6 bar

The **mini** widens the range of applications in the light duty sector as a handy, flexible and universally deployable hoist making it an ideal tool for a wide range of light/medium manufacturing applications.

### mini Manipulator

With the mini manipulator loads can be lifted, lowered, manually traversed and positioned with only one hand. Further information on request.

Explosion Classification:  
II 3 GD IIA T4



## The advantages at a glance

- Price competitive alternative when compared to other types of powered hoists.
- Suitable for lube-free operation.
- Suitable for application in hazardous areas.
- Minimum components for ease of maintenance.
- Wear resistant motor braking system.
- Lightweight for easy handling.
- Also suitable for horizontal pulling.
- Extremely sensitive lever control with emergency shut-off valve, max. control length 6 m.
- Available lifting heights: up to 8m.
- With chain box as standard.
- With manual trolley as option.

## Technical Data

| Type   |                     | mini 125  | mini 250 | mini 500 | mini 1000 |
|--|---------------------|-----------|----------|----------|-----------|
| Capacity   | lbs                 | 275       | 550      | 1100     | 2160      |
|  | kg                  | 125       | 250      | 500      | 980       |
| Air pressure                                     | PSI                 | 85        | 85       | 85       | 85        |
|  | bar                 | 6         | 6        | 6        | 6         |
| Number of chain strands                          |                     | 1         | 1        | 1        | 1         |
| Motor output                                     | kW                  | 0.4       | 0.4      | 1        | 1         |
|  |                     |           |          |          |           |
| Lifting speed at full load <sup>1</sup>          | ft/min              | 49.5      | 26       | 33       | 16        |
|  | m/min               | 15        | 8        | 10       | 5         |
| Lifting speed without load <sup>1</sup>          | ft/min              | 130       | 65       | 65       | 33        |
|  | m/min               | 40        | 20       | 20       | 10        |
| Lowering speed at full load                      | ft/min              | 99        | 52       | 59       | 33        |
|  | m/min               | 30        | 16       | 18       | 10        |
| Lowering speed without load                      | ft/min              | 78.7      | 39.4     | 39.4     | 19.7      |
|  | m/min               | 24        | 12       | 12       | 6         |
| Air consumption at full load – lifting           | cfm                 | 17.5      | 17.5     | 42.5     | 42.5      |
|  | m <sup>3</sup> /min | 0.5       | 0.5      | 1.2      | 1.2       |
| Air consumption at full load – lowering          | cfm                 | 24.7      | 24.7     | 56.5     | 56.5      |
|  | m <sup>3</sup> /min | 0.7       | 0.7      | 1.6      | 1.6       |
| Air connection                                   |                     | G 3/8     | G 3/8    | G 1/2    | G 1/2     |
| Hose dimension (Ø inside)                        | inch                | 3/8       | 3/8      | 1/2      | 1/2       |
|  | mm                  | 9         | 9        | 13       | 13        |
| Weight with 10 ft / 3 m lift                     | lbs                 | 21        | 23.1     | 46.2     | 50.6      |
|  | kg                  | 9.5       | 10.5     | 21       | 23        |
| Chain dimension                                  | mm                  | 4 x 12    | 4 x 12   | 7 x 21   | 7 x 21    |
|  |                     |           |          |          |           |
| Weight of chain                                  | lbs/ft              | 0.23      | 0.23     | 0.67     | 0.67      |
|  | kg/m                | 0.35      | 0.35     | 1.0      | 1.0       |
| Height of lift                                   | ft                  | 10/16/26  |          |          |           |
|  | m                   | 3/5/8     |          |          |           |
| Length of control at standard lift               | ft                  | 6.5/13/20 |          |          |           |
|  | m                   | 2/4/6     |          |          |           |
| Noise level at full load <sup>2</sup> – lifting  | dB(A)               | 79        | 79       | 77       | 77        |
| Noise level at full load <sup>2</sup> – lowering | dB(A)               | 80        | 80       | 83       | 83        |

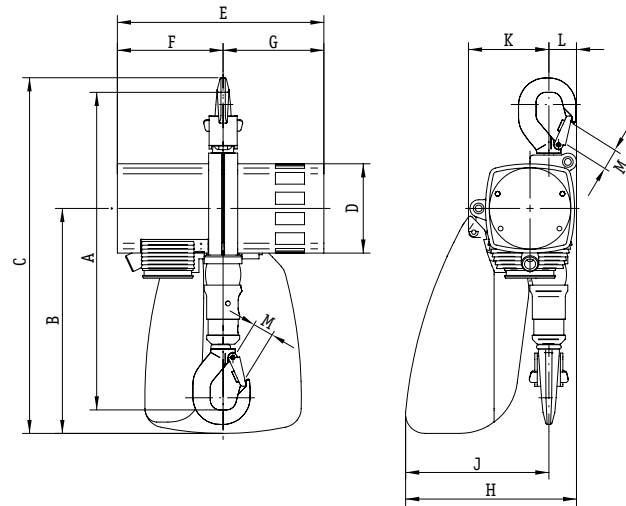
Group mechanism: M3 (1 Bm)

<sup>1</sup>Lifting speed at 2 m length of control. Longer control hoses decrease the lifting speeds.

<sup>2</sup>Measured at 1 m distance acc. to DIN 45635 part 20

## Dimensions

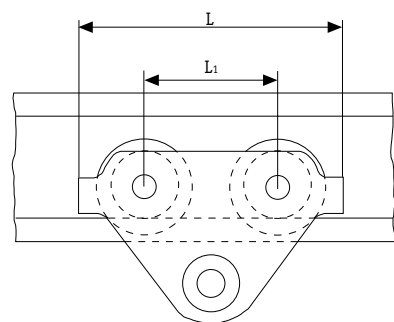
| Type |      | mini 125 | mini 250 | mini 500 | mini 1000 |
|------|------|----------|----------|----------|-----------|
| A    | inch | 12.9     | 12.9     | 18.0     | 18.0      |
|      | mm   | 328      | 328      | 458      | 458       |
| B    | inch | 9.1      | 9.1      | 12.4     | 12.4      |
|      | mm   | 232      | 232      | 316      | 316       |
| C    | inch | 14.4     | 14.4     | 19.9     | 19.9      |
|      | mm   | 367      | 367      | 505      | 505       |
| D    | inch | 3.6      | 3.6      | 4.8      | 4.8       |
|      | mm   | 92       | 92       | 122      | 122       |
| E    | inch | 8.4      | 8.4      | 11.5     | 11.5      |
|      | mm   | 213      | 213      | 292      | 292       |
| F    | inch | 4.3      | 4.3      | 5.8      | 5.8       |
|      | mm   | 109      | 109      | 148      | 148       |
| G    | inch | 4.1      | 4.1      | 5.6      | 5.6       |
|      | mm   | 104      | 104      | 144      | 144       |
| H    | inch | 7        | 7        | 9.2      | 9.2       |
|      | mm   | 177      | 177      | 234      | 234       |
| J    | inch | 5.8      | 5.8      | 7.6      | 7.6       |
|      | mm   | 148      | 148      | 194      | 194       |
| K    | inch | 3.3      | 3.3      | 4.7      | 4.7       |
|      | mm   | 83       | 83       | 119      | 119       |
| L    | inch | 1.1      | 1.1      | 1.6      | 1.6       |
|      | mm   | 29       | 29       | 40       | 40        |
| M    | inch | 0.7      | 0.7      | 1.1      | 1.1       |
|      | mm   | 19       | 19       | 28       | 28        |



## Manual Trolleys for JDN Air Hoists mini

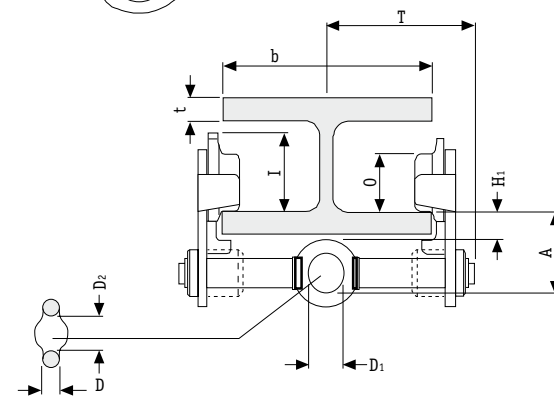
### Technical Data

| Type                    |      | LN 250 | LN 1000 |
|-------------------------|------|--------|---------|
| Capacity                | lbs  | 550    | 2200    |
|                         | kg   | 250    | 1000    |
| Beam flange width b     | inch | 2-8    | 2-8     |
|                         | mm   | 50-220 | 58-220  |
| max. flange thickness t | inch | 1.3    | 1.2     |
|                         | mm   | 34     | 30      |
| min. curve radius       | inch | 35.4   | 39.4    |
|                         | m    | 0.9    | 1.0     |
| Weight                  | lbs  | 17     | 21      |
|                         | kg   | 7.7    | 10.5    |



## Dimensions

| Type           |      | LN 250 | LN 1000 |
|----------------|------|--------|---------|
| A              | inch | 3.1    | 3.1     |
|                | mm   | 79     | 79      |
| D              | inch | 0.7    | 0.7     |
|                | mm   | 17     | 17      |
| D <sub>1</sub> | inch | 1      | 1.2     |
|                | mm   | 25     | 30      |
| D <sub>2</sub> | inch | 1.2    | 1.4     |
|                | mm   | 30     | 35      |
| H <sub>1</sub> | inch | 1.2    | 1       |
|                | mm   | 30     | 25      |
| I              | inch | 2.7    | 3.2     |
|                | mm   | 67.5   | 81.5    |
| L              | inch | 10.2   | 10.2    |
|                | mm   | 260    | 260     |
| L <sub>1</sub> | inch | 5.1    | 5.1     |
|                | mm   | 130    | 130     |
| O              | inch | 2.2    | 2.7     |
|                | mm   | 55     | 68      |
| T              | inch | 5.7    | 5.9     |
|                | mm   | 144    | 151     |



## JDN AIR HOISTS Profi

Capacities: 250 kg up to 100 t

Air pressure: 4 bar or 6 bar

Proven in practice: JDN Air Hoists **PROFI** Series are superior in all places where safety has priority. The **PROFI** Series scores well with its 100% duty rating and explosion protection as standard. This important advantage ensures JDN Air Hoists are especially suitable for applications in hazardous areas.

JDN Air Hoists **PROFI** Series are very robust and therefore suitable for tough industrial applications even in continuous working processes. According to your requirements there are various control systems available. For traversing loads there are also different trolley designs to meet your particular demands.

### Where the JDN PROFI excellence has been proven

Aircraft construction, assembly lines, chemical industry, dairies, electro plating, explosives and pyrotechnics industry, food industry, foundries, furniture industry, glass industry, lacquer and varnish factories, match industry, mechanical engineering, auto industry, oil storage plants, on- and offshore, paint shops, paper industry, power plants, refineries, sawmills, shipyards, space industry, tempering plants, textile industry.

### Standard Features

- Suitable for application in hazardous areas
- Sensitive infinitely variable speed control for the precise positioning of loads
- Easy operation
- Suitable for lube-free operation
- 100 % duty rating and unlimited duty cycles
- Low maintenance
- Low headroom, lightweight
- Sound absorption
- Insensitive to dust, humidity and temperatures ranging from -20°C up to +70°C
- From 1t upwards with overload protection (EC-version)

### Technical Details

- Fail-safe starting, low maintenance vane motor
- Chain sprocket in the mid section runs in dust-proof maintenance-free ball bearings
- Planetary gear box with long-life grease lubrication, all gears made of tempered or hardened high-grade steel
- Load chain and hooks manufactured from high quality tempered steels with a breaking strength of five times the nominal load

### The advantages at a glance

- **Strong – Fast – Silent**  
High performance with more efficiency by reliability plus high lifting and lowering speeds. Low sound emissions.
- **High Level of Safety**  
Integrated emergency stop switch from 1t upwards with overload protection.
- **Oil-Free Operation**  
Patented, permanent motor lubrication during operation, using a high-performance grease. No additional motor lubrication required.
- **Patented Motor-Brake System**  
For operation with low maintenance and little wear. Based on the proven design of the JDN Mini Series.
- **Modern Design – Compact Size**  
Features no protruding control hoses or parts susceptible to damage, making the PROFI also suitable for horizontal pulling.
- **100% Duty Rating – No Downtime**
- **Ex Classification according to EC Directive on Hazardous Locations 94/9/EEC**  
As standard:  
 Ⓜ II 2 GD IIA T4/II 3 GD IIB T4  
 With increased spark protection:  
 Ⓜ II 2 GD IIC T4





The modular system at a glance



PROFI 025TI – 2TI

Technical Data

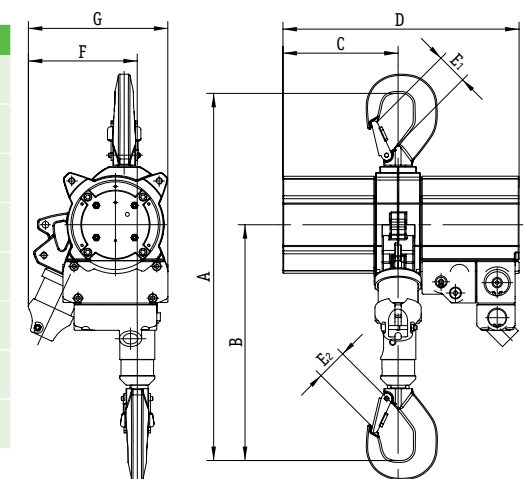
| Type   |                     | 025 TI |       | 05 TI  |      | 1 TI   |                   | 2 TI            |                 |
|--|---------------------|--------|-------|--------|------|--------|-------------------|-----------------|-----------------|
| Capacity   | mt                  | 0.16   | 0.25  | 0.32   | 0.5  | 0.63   | 1                 | 1.25            | 2               |
| Air pressure                                     | PSI                 | 65     | 85    | 65     | 85   | 65     | 85                | 65              | 85              |
|  | bar                 | 4      | 6     | 4      | 6    | 4      | 6                 | 4               | 6               |
| Number of chain strands                          |                     | 1      |       | 1      |      | 1      |                   | 2               |                 |
| Motor output                                     | kW                  | 0.6    | 1.0   | 0.6    | 1.0  | 0.6    | 1.0               | 0.6             | 1.0             |
| Lifting speed at full load                       | ft/min              | 65.6   | 65.6  | 32.8   | 36.1 | 16.4   | 18                | 8.2             | 8.9             |
|  | m/min               | 20     | 20    | 10     | 11   | 5      | 5.5               | 2.5             | 2.7             |
| Lifting speed without load                       | ft/min              | 123    | 137.8 | 52.5   | 62.3 | 32.8   | 36.1              | 16.4            | 18              |
|  | m/min               | 37.5   | 42    | 16     | 19   | 10     | 11                | 5               | 5.5             |
| Lowering speed at full load                      | ft/min              | 124.7  | 124.7 | 55.8   | 55.8 | 32.8   | 36.1              | 16.4            | 18              |
|  | m/min               | 38     | 38    | 17     | 17   | 10     | 11                | 5               | 5.5             |
| Air consumption at full load – lifting           | cfm                 | 24.7   | 42.4  | 24.7   | 42.4 | 24.7   | 42.4              | 24.7            | 42.4            |
|  | m <sup>3</sup> /min | 0.7    | 1.2   | 0.7    | 1.2  | 0.7    | 1.2               | 0.7             | 1.2             |
| Air consumption at full load – lowering          | cfm                 | 28.3   | 53    | 28.3   | 53   | 28.3   | 53                | 28.3            | 53              |
|  | m <sup>3</sup> /min | 0.8    | 1.5   | 0.8    | 1.5  | 0.8    | 1.5               | 0.8             | 1.5             |
| Air connection                                   |                     | G 1/2  |       | G 1/2  |      | G 1/2  |                   | G 1/2           |                 |
| Hose dimension (ø inside)                        | inch                | 1/2    |       | 1/2    |      | 1/2    |                   | 1/2             |                 |
|  | mm                  | 13     |       | 13     |      | 13     |                   | 13              |                 |
| Weight with standard lift, rope control          | lbs                 | 59.5   | 59.5  | 59.5   | 59.5 | 61.6   | 61.7 <sup>1</sup> | 75 <sup>1</sup> | 75 <sup>1</sup> |
|  | kg                  | 27     | 27    | 27     | 27   | 27.5   | 28 <sup>1</sup>   | 34 <sup>1</sup> | 34 <sup>1</sup> |
| Chain dimension                                  | mm                  | 7 x 21 |       | 7 x 21 |      | 7 x 21 |                   | 7 x 21          |                 |
| Weight of chain                                  | lbs/ft              | 0.67   |       | 0.67   |      | 0.67   |                   | 0.67            |                 |
|  | kg/m                | 1.0    |       | 1.0    |      | 1.0    |                   | 1.0             |                 |
| Standard lift                                    | ft                  | 10     |       | 10     |      | 10     |                   | 10              |                 |
|  | m                   | 3      |       | 3      |      | 3      |                   | 3               |                 |
| Length of control at standard lift               | ft                  | 6.5    |       | 6.5    |      | 6.5    |                   | 6.5             |                 |
|  | m                   | 2      |       | 2      |      | 2      |                   | 2               |                 |
| Noise level at full load <sup>2</sup> – lifting  | dB(A)               | 73     | 74    | 74     | 75   | 74     | 76                | 74              | 76              |
| Noise level at full load <sup>2</sup> – lowering | dB(A)               | 77     | 78    | 77     | 78   | 77     | 78                | 77              | 78              |

<sup>1</sup>With overload protection  
<sup>2</sup>Measured at 1 m distance acc. to DIN 45635 part 20  
 Group mechanism at 6 bar: PROFI 025TI M5 (2 m), PROFI 05TI - PROFI 2TI M4 (1 Am)



Dimensions

| Type                         |      | 025 TI | 05 TI | 1 TI | 2 TI |
|------------------------------|------|--------|-------|------|------|
| A min. headroom <sup>1</sup> | inch | 17.7   | 17.7  | 17.7 | 19.6 |
|                              | mm   | 450    | 450   | 450  | 498  |
| B                            | inch | 11.3   | 11.3  | 11.3 | 13.2 |
|                              | mm   | 288    | 288   | 288  | 336  |
| C                            | inch | 5.7    | 5.7   | 5.7  | 5.7  |
|                              | mm   | 145    | 145   | 145  | 145  |
| D                            | inch | 11.7   | 11.7  | 11.7 | 11.7 |
|                              | mm   | 297    | 297   | 297  | 297  |
| E <sub>1</sub>               | inch | 1.1    | 1.1   | 1.1  | 1.1  |
|                              | mm   | 28     | 28    | 28   | 28   |
| E <sub>2</sub>               | inch | 1.1    | 1.1   | 1.1  | 1.1  |
|                              | mm   | 28     | 28    | 28   | 28   |
| F up to hook centre          | inch | 5.4    | 5.4   | 5.4  | 5.4  |
|                              | mm   | 137    | 137   | 137  | 137  |
| G maximum width              | inch | 6.9    | 6.9   | 6.9  | 7.2  |
|                              | mm   | 176    | 176   | 176  | 183  |



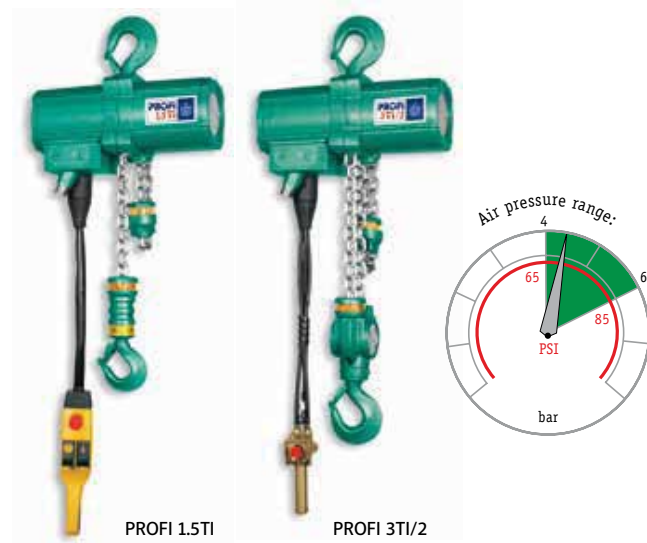
<sup>1</sup>Chain containers increase the hoist headroom

**PROFI 1.5TI and 3TI/2**

Technical Data

| Type   |                     | 1.5TI     | 3 TI/2    |
|--|---------------------|-----------|-----------|
| Capacity   | mt                  | 1.6       | 3.2       |
| Air pressure range                               | PSI                 | 65-85     | 65-85     |
|  | bar                 | 4-6       | 4-6       |
| Number of chain strands                          |                     | 1         | 2         |
| Motor output                                     | kW                  | 1.3-2     | 1.3-2     |
| Lifting speed at full load                       | ft/min              | 13.1-19.7 | 6.6-9.8   |
|  | m/min               | 4-6       | 2-3       |
| Lifting speed without load                       | ft/min              | 27.6-32.8 | 13.8-16.4 |
|  | m/min               | 8.4-10    | 4.2-5     |
| Lowering speed at full load                      | ft/min              | 36.1-39.4 | 18.0-19.7 |
|  | m/min               | 11-12     | 5.5-6     |
| Air consumption at full load - lifting           | cfm                 | 53-92     | 53-92     |
|  | m <sup>3</sup> /min | 1.5-2.6   | 1.5-2.6   |
| Air consumption at full load - lowering          | cfm                 | 78-127    | 78-127    |
|  | m <sup>3</sup> /min | 2.2-3.6   | 2.2-3.6   |
| Air connection                                   |                     | G 3/4     | G 3/4     |
| Hose dimension (Ø inside)                        | inch                | 3/4       | 3/4       |
|  | mm                  | 19        | 19        |
| Weight with standard lift, rope control          | lbs                 | 123       | 146       |
|  | kg                  | 56        | 66        |
| Chain dimension                                  | mm                  | 9 x 27    | 9 x 27    |
| Weight of chain                                  | lbs/ft              | 1.2       | 1.2       |
|  | kg/m                | 1.8       | 1.8       |
| Standard lift                                    | ft                  | 10        | 10        |
|  | m                   | 3         | 3         |
| Length of control at standard lift               | ft                  | 6.5       | 6.5       |
|  | m                   | 2         | 2         |
| Noise level at full load <sup>1</sup> - lifting  | dB(A)               | 73-77     | 73-77     |
| Noise level at full load <sup>1</sup> - lowering | dB(A)               | 78-80     | 78-80     |

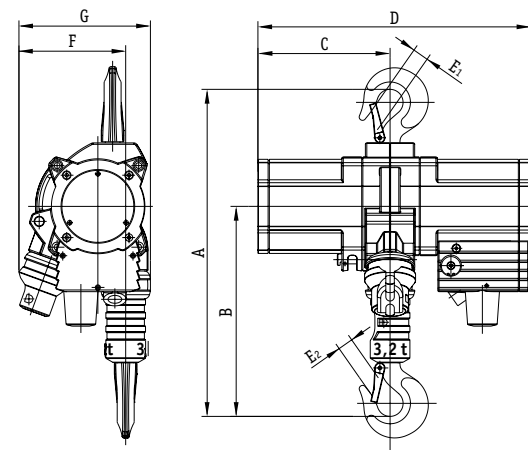
<sup>1</sup>Measured at 1 m distance acc. to DIN 45635 part 20  
Group mechanism: M3 (1 Bm)



Dimension

| Type                         |      | 1.5 TI | 3 TI/2 |
|------------------------------|------|--------|--------|
| A min. headroom <sup>1</sup> | inch | 18.9   | 21.4   |
|                              | mm   | 480    | 544    |
| B                            | inch | 11.5   | 14.0   |
|                              | mm   | 293    | 356    |
| C                            | inch | 7.9    | 7.9    |
|                              | mm   | 200    | 200    |
| D                            | inch | 16.2   | 16.2   |
|                              | mm   | 412    | 412    |
| E <sub>1</sub>               | inch | 1.1    | 1.1    |
|                              | mm   | 28     | 28     |
| E <sub>2</sub>               | inch | 1.0    | 1.1    |
|                              | mm   | 26     | 28     |
| F up to hook centre          | inch | 6.7    | 5.5    |
|                              | mm   | 170    | 140    |
| G maximum width              | inch | 8.5    | 8.5    |
|                              | mm   | 215    | 215    |

<sup>1</sup>Chain containers increase the hoist headroom



**PROFI 3TI – 20TI**

Technical Data

| Type   |                     | 3 TI      | 6 TI      | 10 TI    | 16 TI   | 20 TI   |
|--|---------------------|-----------|-----------|----------|---------|---------|
| Capacity   | mt                  | 3.2       | 6.3       | 10       | 16      | 20      |
| Air pressure                                     | PSI                 | 65 85     | 65 85     | 65 85    | 65 85   | 65 85   |
|  | bar                 | 4 6       | 4 6       | 4 6      | 4 6     | 4 6     |
| Number of chain strands                          |                     | 1         | 2         | 2        | 3       | 4       |
| Motor output                                     | kW                  | 1.8 3.5   | 1.8 3.5   | 1.8 3.5  | 1.8 3.5 | 1.8 3.5 |
| Lifting speed at full load                       | ft/min              | 8.2 16.4  | 3.9 8.2   | 2.6 5.2  | 1.6 3.3 | 1.3 2.3 |
|  | m/min               | 2.5 5     | 1.2 2.5   | 0.8 1.6  | 0.5 1   | 0.4 0.7 |
| Lifting speed without load                       | ft/min              | 19.7 32.8 | 9.8 16.4  | 6.6 10.5 | 4.3 6.6 | 3.3 4.6 |
|  | m/min               | 6 10      | 3 5       | 2 3.2    | 1.3 2   | 1 1.4   |
| Lowering speed at full load                      | ft/min              | 24.6 35.4 | 11.8 17.7 | 8.2 11.2 | 5.3 6.9 | 3.9 5.3 |
|  | m/min               | 7.5 10.8  | 3.6 5.4   | 2.5 3.4  | 1.6 2.1 | 1.2 1.6 |
| Air consumption at full load - lifting           | cfm                 | 71 142    | 71 142    | 71 142   | 71 142  | 71 142  |
|  | m <sup>3</sup> /min | 2 4       | 2 4       | 2 4      | 2 4     | 2 4     |
| Air consumption at full load - lowering          | cfm                 | 124 195   | 124 195   | 124 195  | 124 195 | 124 195 |
|  | m <sup>3</sup> /min | 3.5 5.5   | 3.5 5.5   | 3.5 5.5  | 3.5 5.5 | 3.5 5.5 |
| Air connection                                   |                     | G 3/4     | G 3/4     | G 3/4    | G 3/4   | G 3/4   |
| Hose dimension (Ø inside)                        | inch                | 3/4       | 3/4       | 3/4      | 3/4     | 3/4     |
|  | mm                  | 19        | 19        | 19       | 19      | 19      |
| Weight with standard lift, rope control          | lbs                 | 189.6     | 242.5     | 343.9    | 529.1   | 627     |
|  | kg                  | 86        | 110       | 156      | 240     | 285     |
| Chain dimension                                  | mm                  | 13 x 36   | 13 x 36   | 16 x 45  | 16 x 45 | 16 x 45 |
| Weight of chain                                  | lbs/ft              | 2.6       | 2.6       | 3.9      | 3.9     | 3.9     |
|  | kg/m                | 3.8       | 3.8       | 5.8      | 5.8     | 5.8     |
| Standard lift                                    | ft                  | 10        | 10        | 10       | 10      | 10      |
|  | m                   | 3         | 3         | 3        | 3       | 3       |
| Length of control at standard lift               | ft                  | 6.5       | 6.5       | 6.5      | 6.5     | 6.5     |
|  | m                   | 2         | 2         | 2        | 2       | 2       |
| Noise level at full load <sup>1</sup> - lifting  | dB(A)               | 74 78     | 74 78     | 74 78    | 74 78   | 74 78   |
| Noise level at full load <sup>1</sup> - lowering | dB(A)               | 79 80     | 79 80     | 79 80    | 79 80   | 79 80   |

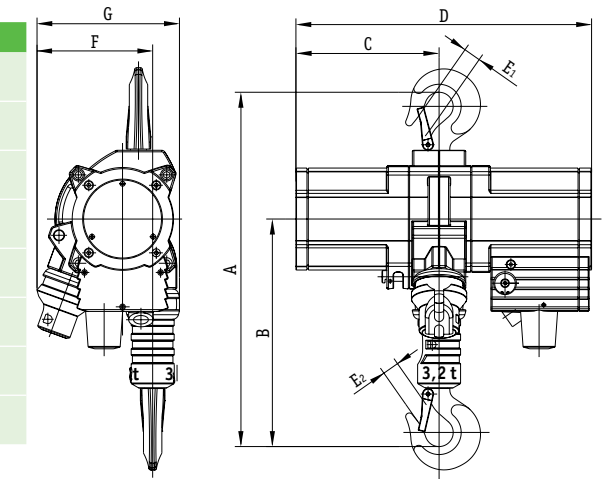
<sup>1</sup>Measured at 1 m distance acc. to DIN 45635 part 20  
Group mechanism at 6 bar: M3 (1 Bm)



Dimensions

| Type                         |      | 3 TI | 6 TI | 10 TI | 16 TI | 20 TI |
|------------------------------|------|------|------|-------|-------|-------|
| A min. headroom <sup>1</sup> | inch | 23.3 | 26.5 | 32    | 35.4  | 40.6  |
|                              | mm   | 593  | 674  | 813   | 898   | 1030  |
| B                            | inch | 14.7 | 17.9 | 21.6  | 23.5  | 26.4  |
|                              | mm   | 373  | 454  | 548   | 598   | 670   |
| C                            | inch | 9.2  | 9.2  | 12.1  | 15    | 15    |
|                              | mm   | 233  | 233  | 308   | 382   | 382   |
| D                            | inch | 19   | 19   | 22.6  | 27.2  | 27.2  |
|                              | mm   | 483  | 483  | 575   | 692   | 692   |
| E <sub>1</sub>               | inch | 1.6  | 1.6  | 1.7   | 2.1   | 2.8   |
|                              | mm   | 40   | 40   | 44    | 53    | 70    |
| E <sub>2</sub>               | inch | 1.2  | 1.6  | 1.7   | 2.1   | 2.8   |
|                              | mm   | 30   | 40   | 44    | 53    | 70    |
| F up to hook centre          | inch | 7.4  | 6.1  | 7.8   | 7.8   | 7.1   |
|                              | mm   | 187  | 154  | 197   | 199   | 180   |
| G maximum width              | inch | 9.2  | 9.2  | 12    | 12.1  | 12.4  |
|                              | mm   | 233  | 233  | 306   | 308   | 315   |

<sup>1</sup>Chain containers increase the hoist headroom



**J·D·NEUHAUS** 1745 engineered for extremes  
**JDN Trolleys**

Capacities: 0.25 t up to 20 t

JDN Trolleys are available for all hoists of the PROFI and M series:

- Manual trolleys (LN) for pushing or pulling the trolleys by hand
- Reel chain trolleys (LH) for moving the trolleys by operating the reel chain mechanism
- Motorised trolley (LM) air motor powered

**Options**

- Rack and pinion drive
- Spark-resistant package
- Offshore paint

**Energy Feeding Systems**

The air supply can be fed by various systems:

- Energy chain
- C-rail
- Square rail
- Spiral hose
- Hose trolleys

**Standard Features**

- Easy to install
- With anti-climb and anti-drop devices
- Robust manufacture requiring little maintenance
- Able to negotiate curves



PROFI 1TI in Manual Trolley



PROFI 1TI in Reel Chain Trolley



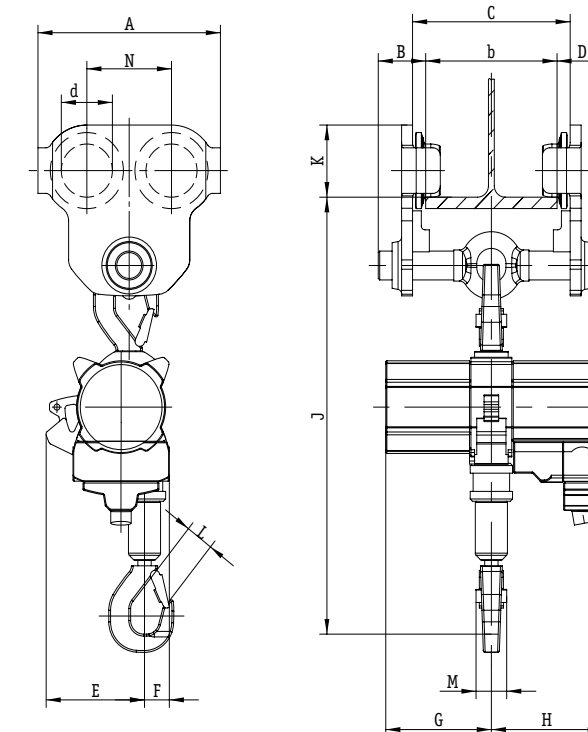
PROFI 2TI in Motor Trolley

**PROFI in Manual Trolley (LN)**

**Dimensions**

| JDN Air Hoist PROFI |      | 025 TI   | 05 TI | 1 TI   | 1.5 TI | 2 TI | 3 TI/2   | 3 TI | 6 TI     | 10 TI      | 16 TI |
|---------------------|------|----------|-------|--------|--------|------|----------|------|----------|------------|-------|
| With Trolley        |      | LN 0.5 t |       | LN 1 t | LN 2 t |      | LN 3.2 t |      | LN 6.3 t | LN 10-16 t |       |
| A                   | inch | 10.2     |       |        | 12.2   |      | 11.5     |      | 19.7     | 19.3       |       |
|                     | mm   | 260      |       |        | 310    |      | 292      |      | 500      | 490        |       |
| B max.              | inch | 4.7      |       |        | 4.8    |      | 4.5      |      | 6.2      | 6.4        |       |
|                     | mm   | 119      |       |        | 122    |      | 113      |      | 157      | 162        |       |
| C                   | inch | b + 1.1  |       |        | b + 1  |      | b + 2.4  |      |          | b + 2.8    |       |
|                     | mm   | b + 28   |       |        | b + 26 |      | b + 60   |      |          | b + 70     |       |
| d                   | inch | 2.2      |       | 2.7    | 3.2    |      | 3.3      |      |          | 6.5        |       |
|                     | mm   | 55       |       | 68     | 80     |      | 84       |      |          | 165        |       |
| D max.              | inch | 4.7      |       |        | 4.8    |      | 4.5      |      | 6.2      | 6.4        |       |
|                     | mm   | 119      |       |        | 122    |      | 113      |      | 157      | 162        |       |
| E                   | inch | 5.4      |       |        | 5.7    | 5.4  | 5.5      | 7.4  | 6.1      | 7.8        | 7.8   |
|                     | mm   | 137      |       |        | 170    | 137  | 140      | 187  | 154      | 197        | 199   |
| F                   | inch | 1.5      |       |        | 1.8    | 1.8  | 3.0      | 1.8  | 3.1      |            | 4.3   |
|                     | mm   | 39       |       |        | 45     | 46   | 75       | 46   | 79       |            | 109   |
| G                   | inch | 5.7      |       |        | 7.9    | 5.7  | 7.9      |      | 9.2      | 12.1       | 15    |
|                     | mm   | 145      |       |        | 200    | 145  | 200      |      | 233      | 308        | 382   |
| H                   | inch | 6        |       |        | 3.3    | 6    | 3.3      |      | 9.8      | 10.5       | 12.2  |
|                     | mm   | 152      |       |        | 212    | 152  | 212      |      | 250      | 267        | 310   |
| J* (mounted)        | inch | -        | -     | -      | -      | -    | 24.1     | 25   | 30       | 37         | 39    |
|                     | mm   | -        | -     | -      | -      | -    | 613      | 635  | 763      | 929        | 982   |
| J* (suspended)      | inch | 20.9     |       |        | 23.1   | 23.5 | -        | 31.4 | 36.2     | 46.3       | 49.6  |
|                     | mm   | 530      |       |        | 588    | 597  | -        | 798  | 919      | 1176       | 1260  |
| K                   | inch | 2.7      |       | 3.2    | 3.7    |      | 4.2      |      |          | 7.4        |       |
|                     | mm   | 67.5     |       | 81.5   | 94     |      | 107      |      |          | 188        |       |
| L                   | inch | 1.1      |       |        | 1.0    | 1.1  | 1.2      | 1.6  | 1.7      | 2.1        | 2.1   |
|                     | mm   | 28       |       |        | 26     | 28   | 30       | 40   | 44       | 53         | 53    |
| M                   | inch | 1.7      |       |        | 1.6    | 1.7  |          | 2    | 2.6      | 3.2        | 3.2   |
|                     | mm   | 42       |       |        | 40     | 42   |          | 51   | 66       | 82         | 82    |
| N                   | inch | 5.1      |       |        | 5.9    |      | 5.4      |      |          | 9.3        |       |
|                     | mm   | 130      |       |        | 150    |      | 136      |      |          | 236        |       |

\*Chain containers increase the hoist headroom



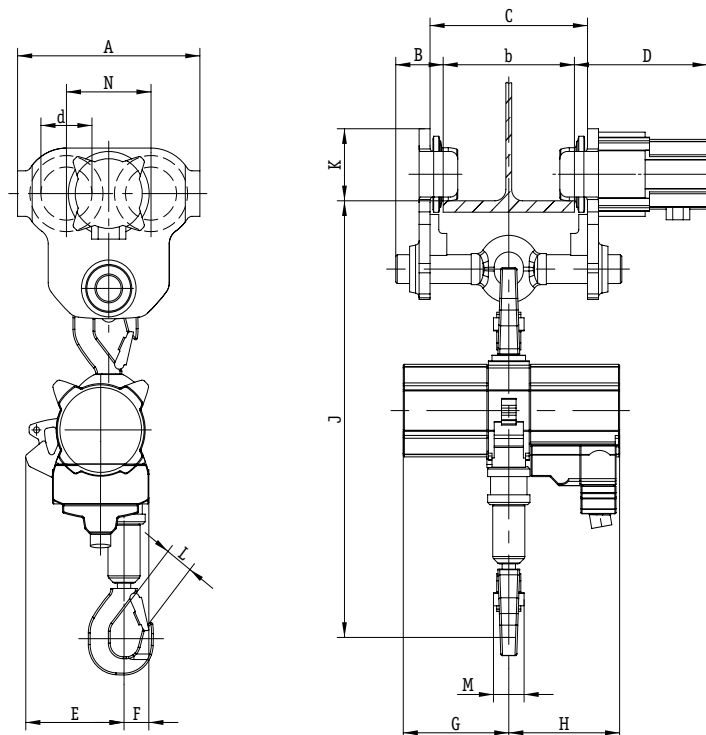


## PROFI in Motor Trolley (LM)

### Dimensions

| JDN Air Hoist PROFI |            | 025 TI | 05 TI       | 1 TI              | 1.5 TI      | 2 TI        | 3 TI/2            | 3 TI        | 6 TI        | 10 TI             | 16 TI        | 20 TI             |
|---------------------|------------|--------|-------------|-------------------|-------------|-------------|-------------------|-------------|-------------|-------------------|--------------|-------------------|
| With Trolley        |            |        |             | LM 2 t            |             |             | LM 3.2 t          | LM 6.3 t    |             | LM 10-16 t        |              | LM 20 t           |
| A                   | inch<br>mm |        |             | 9.8<br>250        |             |             | 11.5<br>292       | 19.7<br>500 |             | 19.3<br>490       |              | 23.6<br>600       |
| B max.              | inch<br>mm |        |             | 5.1<br>130        |             |             | 4.4<br>113        | 6.2<br>157  |             | 6.4<br>162        |              | 5.3<br>134        |
| C                   | inch<br>mm |        |             | b + 1.4<br>b + 36 |             |             | b + 2.4<br>b + 60 |             |             | b + 2.8<br>b + 70 |              | b + 2.7<br>b + 68 |
| d                   | inch<br>mm |        |             | 2.8<br>70         |             |             | 3.3<br>84         |             |             | 6.5<br>165        |              | 7.3<br>185        |
| D                   | inch<br>mm |        | 7.3<br>185  |                   | 7.3<br>185  | 7.3<br>185  | 7.5<br>191        | 8.1<br>205  |             | 12.5<br>318       |              | 12.9<br>328       |
| E                   | inch<br>mm |        | 5.4<br>137  |                   | 6.7<br>170  | 5.4<br>137  | 5.5<br>140        | 7.4<br>187  | 6.1<br>154  | 7.8<br>197        | 7.8<br>199   | 7.1<br>180        |
| F                   | inch<br>mm |        | 1.5<br>39   |                   | 1.7<br>45   | 1.8<br>46   | 3.0<br>75         | 1.8<br>46   | 3.1<br>79   | 4.3<br>109        |              | 5.3<br>135        |
| G                   | inch<br>mm |        | 5.7<br>145  |                   | 7.9<br>200  | 5.7<br>145  | 7.9<br>200        | 9.2<br>233  |             | 12.1<br>308       |              | 15<br>382         |
| H                   | inch<br>mm |        | 6<br>152    |                   | 3.3<br>212  | 6<br>152    | 3.3<br>212        | 9.8<br>250  |             | 10.5<br>267       |              | 12.2<br>310       |
| J* (mounted)        | inch<br>mm | -<br>- | -<br>-      | -<br>-            | -<br>-      | -<br>-      | 24.1<br>613       | 25<br>635   | 30<br>763   | 37<br>929         | 39<br>982    | 44.3<br>1125      |
| J* (suspended)      | inch<br>mm |        | 22.2<br>563 |                   | 23.7<br>602 | 24.1<br>611 | -<br>-            | 31.4<br>798 | 36.2<br>919 | 46.3<br>1176      | 46.1<br>1171 | 58.1<br>1475      |
| K                   | inch<br>mm |        | 3.7<br>95   |                   |             |             | 4.2<br>107        |             |             | 7.4<br>188        |              | 8.6<br>218        |
| L                   | inch<br>mm |        | 1.1<br>28   |                   | 1.0<br>26   | 1.1<br>28   | 1.2<br>30         | 1.6<br>40   | 1.7<br>42   | 2.1<br>55         | 2.1<br>55    | 2.9<br>75         |
| M                   | inch<br>mm |        | 1.7<br>42   |                   | 1.6<br>40   |             | 1.7<br>42         |             | 2<br>51     | 2.6<br>66         | 3.2<br>82    | 3.4<br>86         |
| N                   | inch<br>mm |        | 4.6<br>116  |                   |             |             | 5.4<br>136        |             |             | 9.3<br>236        |              | 10.8<br>274       |

\*Chain containers increase the hoist headroom



## JDN Low Headroom Trolleys

The trolley solution for restricted headroom areas.

Capacities: 0.5 t up to 6.3 t

Where headroom is restricted and standard trolleys can't meet the lifting height requirements we recommend JDN Low Headroom Trolleys whereby our air hoists are mounted horizontally. When only very low headroom is available we recommend JDN Ultra-Low Monorail Hoist design.

### Standard Features

- Small number of maintenance/wear free moving parts
- No additional motor lubrication required
- 2-step travelling speed
- Adjustable trolley widths to suit your requirements

### Special Features

- Able to negotiate curves
- Extended trolley tie bars for bulky or elongated loads

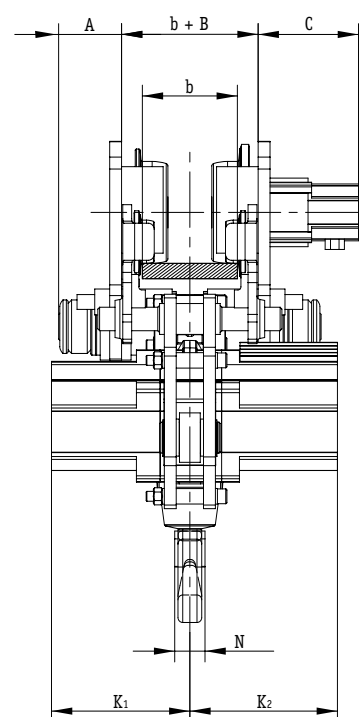
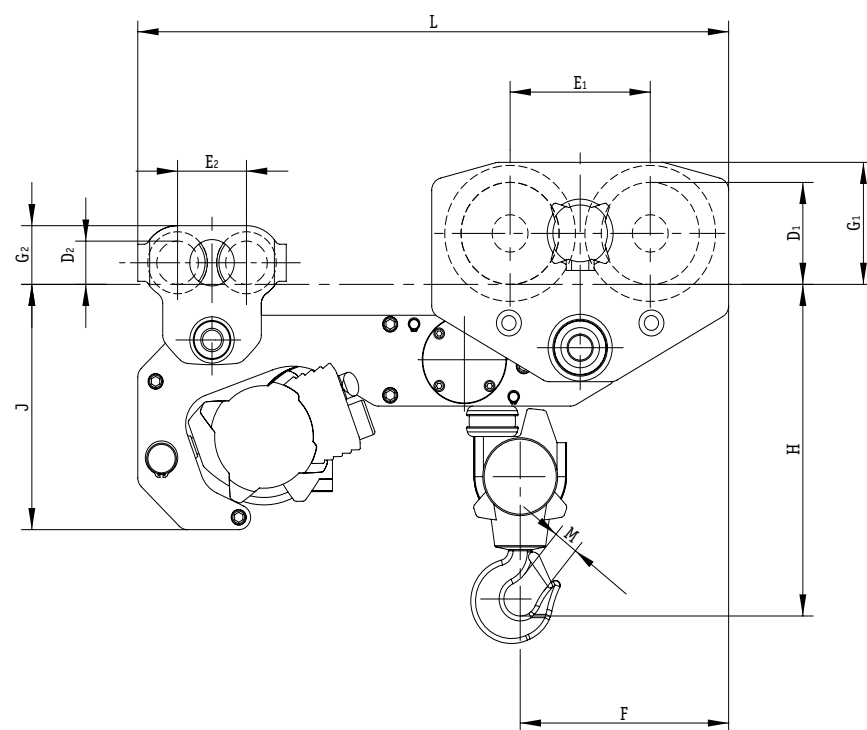
### Technical Data

| Hoist Type                                       |                            | PROFI 05 TI           | PROFI 1 TI            | PROFI 2 TI            | PROFI 3 TI             | PROFI 6 TI             |
|--|----------------------------|-----------------------|-----------------------|-----------------------|------------------------|------------------------|
| Trolley Type                                     |                            | LMF 05-2 t            | LMF 05-2 t            | LMF 05-2 t            | LMF 3.2 t              | LMF 6.3 t              |
| Capacity   | mt                         | 0.5                   | 1                     | 2                     | 3.2                    | 6.3                    |
| Air pressure                                     | PSI<br>bar                 | 85<br>6               | 85<br>6               | 85<br>6               | 85<br>6                | 85<br>6                |
| Number of chain strands                          |                            | 1                     | 1                     | 2                     | 1                      | 2                      |
| Motor output Hoist                               | kW                         | 1                     | 1                     | 1                     | 3.5                    | 3.5                    |
| Motor output Trolley                             | kW                         | 0.2                   | 0.2                   | 0.2                   | 0.2                    | 0.2                    |
| Lifting speed at full load                       | ft/min<br>m/min            | 32.81<br>10           | 16.40<br>5            | 8.20<br>2.5           | 14.76<br>4.5           | 7.21<br>2.2            |
| Lifting speed without load                       | ft/min<br>m/min            | 55.77<br>17           | 32.81<br>10           | 16.40<br>5            | 29.52<br>9             | 14.76<br>4.5           |
| Lowering speed at full load                      | ft/min<br>m/min            | 55.77<br>17           | 36.09<br>11           | 18.04<br>5.5          | 35.43<br>10.8          | 17.72<br>5.4           |
| Travelling speed at full load                    | ft/min<br>m/min            | 29.53*/45.93<br>9*/14 | 29.53*/45.93<br>9*/14 | 29.53*/45.93<br>9*/14 | 29.53*/45.93<br>9*/14  | 29.53*/45.93<br>9*/14  |
| Air consumption at full load – lifting           | cfm<br>m <sup>3</sup> /min | 42.38<br>1.2          | 42.38<br>1.2          | 42.38<br>1.2          | 141.26<br>4            | 141.26<br>4            |
| Air consumption at full load – lowering          | cfm<br>m <sup>3</sup> /min | 52.97<br>1.5          | 52.97<br>1.5          | 52.97<br>1.5          | 194.23<br>5.5          | 194.23<br>5.5          |
| Air consumption trolley motor                    | cfm<br>m <sup>3</sup> /min | 21.19<br>0.6          | 21.19<br>0.6          | 21.19<br>0.6          | 21.19<br>0.6           | 21.19<br>0.6           |
| Air connection                                   |                            | G 1/2                 | G 1/2                 | G 1/2                 | G 3/4                  | G 3/4                  |
| Hose dimension (Ø inside)                        | inch<br>mm                 | 1/2<br>13             | 1/2<br>13             | 1/2<br>13             | 3/4<br>19              | 3/4<br>19              |
| Weight with standard lift and control            | lbs<br>kg                  | 216.05<br>98          | 218.26<br>99          | 231.59<br>105         | 462.97<br>210          | 727.53<br>330          |
| Chain dimension                                  | inch<br>mm                 | 0.28 x 0.83<br>7 x 21 | 0.28 x 0.83<br>7 x 21 | 0.28 x 0.83<br>7 x 21 | 0.51 x 1.42<br>13 x 36 | 0.51 x 1.42<br>13 x 36 |
| Weight of chain                                  | lbs/ft<br>kg/m             | 0.67<br>1             | 0.67<br>1             | 0.67<br>1             | 2.6<br>3.8             | 2.6<br>3.8             |
| Standard lift                                    | ft<br>m                    | 10<br>3               | 10<br>3               | 10<br>3               | 10<br>3                | 10<br>3                |
| Length of control at standard lift               | ft<br>m                    | 6.5<br>2              | 6.5<br>2              | 6.5<br>2              | 6.5<br>2               | 6.5<br>2               |
| Max. bottom flange thickness t                   | inch<br>mm                 | 0.98<br>25            | 0.98<br>25            | 0.98<br>25            | 1.38<br>35             | 1.38<br>35             |
| Max. bottom flange width b                       | inch<br>mm                 | 12.20<br>310          | 12.20<br>310          | 12.20<br>310          | 12.20<br>310           | 12.20<br>310           |
| Min. bottom flange width b                       | inch<br>mm                 | 3.15<br>80            | 3.15<br>80            | 3.15<br>80            | 4.92<br>125            | 4.92<br>125            |
| Noise level at full load <sup>1</sup> – lifting  | dB(A)                      | 75                    | 76                    | 76                    | 78                     | 78                     |
| Noise level at full load <sup>1</sup> – lowering | dB(A)                      | 78                    | 78                    | 78                    | 80                     | 80                     |

\*1st step at F-control with 2-step travelling speed, <sup>1</sup>Measured at 1m distance acc. to DIN 45635 part 20



Low Headroom Trolley LMF



### Dimensions

| Hoist Type     |            | PROFI 05 TI  | PROFI 1 TI   | PROFI 2 TI   | PROFI 3 TI   | PROFI 6 TI   |
|----------------|------------|--------------|--------------|--------------|--------------|--------------|
| Trolley Type   |            | LMF 05-2 t   | LMF 05-2 t   | LMF 05-2 t   | LMF 3.2 t    | LMF 6.3 t    |
| A max.         | inch<br>mm | 4.13<br>105  | 4.13<br>105  | 4.13<br>105  | 4.13<br>105  | 4.17<br>106  |
| B              | inch<br>mm | 1.42<br>36   | 1.42<br>36   | 1.42<br>36   | 1.42<br>36   | 2.76<br>70   |
| b min.         | inch<br>mm | 3.15<br>80   | 3.15<br>80   | 3.15<br>80   | 3.15<br>80   | 4.92<br>125  |
| C              | inch<br>mm | 6.46<br>164  | 6.46<br>164  | 6.46<br>164  | 6.46<br>164  | 6.65<br>169  |
| D <sub>1</sub> | inch<br>mm | 2.76<br>70   | 2.76<br>70   | 2.76<br>70   | 2.76<br>70   | 6.50<br>165  |
| D <sub>2</sub> | inch<br>mm | 2.76<br>70   | 2.76<br>70   | 2.76<br>70   | 2.76<br>70   | 2.76<br>70   |
| E <sub>1</sub> | inch<br>mm | 4.57<br>116  | 4.57<br>116  | 4.57<br>116  | 4.57<br>116  | 9.29<br>236  |
| E <sub>2</sub> | inch<br>mm | 4.57<br>116  | 4.57<br>116  | 4.57<br>116  | 4.57<br>116  | 4.57<br>116  |
| F              | inch<br>mm | 6.77<br>172  | 6.77<br>172  | 7.68<br>195  | 8.98<br>228  | 13.82<br>351 |
| G <sub>1</sub> | inch<br>mm | 3.74<br>95   | 3.74<br>95   | 3.74<br>95   | 3.74<br>95   | 7.76<br>197  |
| G <sub>2</sub> | inch<br>mm | 3.74<br>95   | 3.74<br>95   | 3.74<br>95   | 3.74<br>95   | 3.74<br>95   |
| H min.         | inch<br>mm | 12.60<br>320 | 12.60<br>320 | 15.51<br>394 | 16.34<br>415 | 21.14<br>537 |
| J              | inch<br>mm | 12.60<br>320 | 12.60<br>320 | 12.60<br>320 | 15.63<br>397 | 15.63<br>397 |
| K <sub>1</sub> | inch<br>mm | 5.71<br>145  | 5.71<br>145  | 5.71<br>145  | 9.17<br>233  | 9.17<br>233  |
| K <sub>2</sub> | inch<br>mm | 5.98<br>152  | 5.98<br>152  | 5.98<br>152  | 9.76<br>248  | 9.76<br>248  |
| L              | inch<br>mm | 28.15<br>715 | 28.15<br>715 | 28.15<br>715 | 32.48<br>825 | 39.17<br>995 |
| M              | inch<br>mm | 1.10<br>28   | 1.10<br>28   | 1.10<br>28   | 1.18<br>30   | 1.57<br>40   |
| N              | inch<br>mm | 1.65<br>42   | 1.65<br>42   | 1.65<br>42   | 1.65<br>42   | 2.01<br>51   |
| t max.         | inch<br>mm | 0.98<br>25   | 0.98<br>25   | 0.98<br>25   | 1.38<br>35   | 1.38<br>35   |

## JDN Explosion Protection

### Explosion Accessories

#### JDN Explosion Protection Classification and marking

Hoists and cranes from J.D. Neuhaus have an unbeatable advantage over electrically-driven lifting equipment: Even the standard versions are suitable for use in explosion-hazardous areas and bear explosion-proof labelling according to the ATEX standard. We recommend JDN Ultra-Low Monorail Hoist design.



If you have any questions about the topic of explosion protection, please contact our sales team. We will be happy to advise you.

Example: EX II 2 GD IIB T4 classification means:

| EX   | II                    | 2                      | GD        | IIB                           | T4   |
|--|-----------------------|------------------------|-----------|-------------------------------|--|
| ATEX mandatory marking for equipment usable in explosive atmospheres | II<br>Surface Work    | 2<br>For use in zone 1 | G<br>Gas  | IIC<br>(Acetylene & Hydrogen) | Temperature Class<br>T1 <= 450°C<br>T2 <= 300°C<br>T3 <= 200°C<br>T4 <= 135°C<br>T5 <= 100°C<br>T6 <= 85°C |
|  | I<br>Underground Work | 3<br>For use in zone 2 | D<br>Dust | IIB<br>(Ethylene)             |  |
|  |                       |                        |           | IIA<br>(Propane)              |  |

### JDN Accessories

#### Tailored to your individual needs

We offer a wide range of accessories designed to ensure that JDN standard products are suitable for your specific applications. This means, for example, that you can meet very specific safety requirements, adjust performance capacity or make operations even more convenient.

- Filter silencer
- Filter regulator
- Service unit
- Main air emergency-stop valve
- Chain box
- Special grease cartridge for oil-free operation, volume 250 ml
- Limit switch for lifting and travelling
- Booster valve (control lengths over 12 m)
- Extension arm for control on motorised trolley
- Additional suspension for chain box (for installation in trolley)
- Copper-plated load hook for increased spark protection
- Stainless steel load hook (up to 750 kg capacity)
- Stainless steel chain (reduced capacity) up to 6TI
- Manual emergency lowering device for PROFI 3TI – 20TI hoists
- Special paint finishes



## JDN Controls

JDN Air Hoists and Cranes are available with various controls to suit your special necessities.



### Rope Control

#### Suitable for any control length:

This control type provides infinitely speed control for hoist lifting and lowering motions and is suitable for any required control length. The rope control option is available for all PROFI series hoists up to 25 t capacity. For larger capacity PROFI series hoists 37 TI, 50 TI and 100 TI the rope is replaced by a pull chain for greater strength.



### FI-Control

#### Sensitive control, for easy handling:

The FI-Control provides precise infinitely variable speed control and the ergonomically designed synthetic housing ensures comfortable handling for the operator. The use of corrosion resistant materials makes it suitable for use in aggressive atmospheres, with the control hoses enclosed in an outer sheath which protects them from external conditions.



### E-Control

#### Low maintenance, corrosion-proof:

The very robust brass construction distinguishes the E-type pendant control valve. Low weight and ergonomic design ensure ease of handling. Only available in single speed control version.



### F-Control

#### Available for multi-function use:

The F-control is manufactured from an unbreakable synthetic material, resistant to external conditions. The ergonomically designed housing ensures ease of handling. Up to 18 different control functions can be incorporated in a single pendant control e.g key switch, two stage travelling speed, klaxon or simultaneous control of two hoist motors. As an option the F-control can also be delivered with infinitely variable speed control of hoisting and trolley travelling motions.

#### Controls for JDN Air Hoists in motor trolley and JDN Monorail Hoists

For controlling JDN air hoists in motor trolleys and JDN monorail hoists we recommend the four button version of the E or F-control. The rope control option is also available.

#### Controls for JDN Air Cranes

For controlling JDN air cranes the F-control is the most suitable because of its multi-function capability.

#### Operating Convenience via radio control

To overcome excessive distances between operator and crane, or to use hoisting equipment in remote areas, the JDN Radio Control offers a convenient and safe alternative to other control types. The JDN radio control is also available in explosion-proof design.

# JDN Energy Supplies

A series of supply systems are available for powering JDN Air Hoists in trolleys, monorail hoists and crane systems:

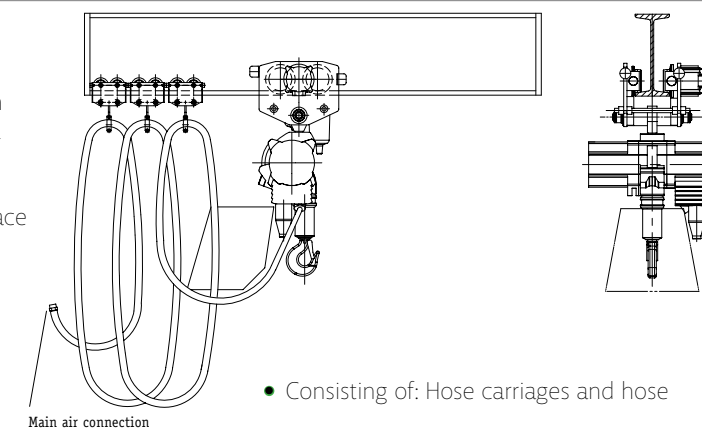
- Hose trolleys
- Spiral hose
- Square bar or C rail
- Energy chain

## Hose trolleys

The hose is fastened to trolleys, which roll directly on the bottom flange of the beam. With each horizontal move of the hoist along the beam, the hose trolleys make the hose follow suit. The hose trolleys will be used for short distances or if there is not enough space on the side of the beam to install C or square bars.

#### Your advantages:

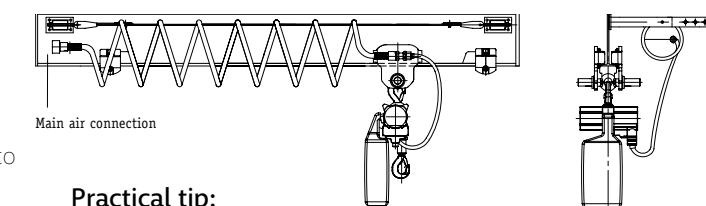
- Easy to install
- Cost-efficient



## Spiral hose

This simple and economical solution is suitable for distances of up to 10 metres. The hose rings are suspended on a plastic-coated rope that runs parallel to the track.

The spiral hose can be used in category 3 (zone 2) with gases in explosion group IIA and IIB. It is not suitable for applications in category 2 (zone 1) or group IIC.



#### Practical tip:

Make sure to lay the hose so that its extended length is roughly 1.5 times the required distance.

- Consisting of: Tensioning arms, rope tensioners, hose and rope

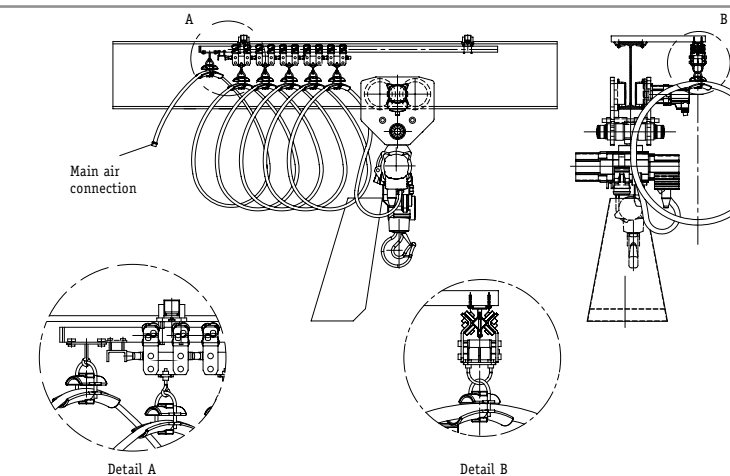
## Square bar & C rail

Galvanised C rails or square bars are installed along the beam to carry the energy supply lines.

### Square bar

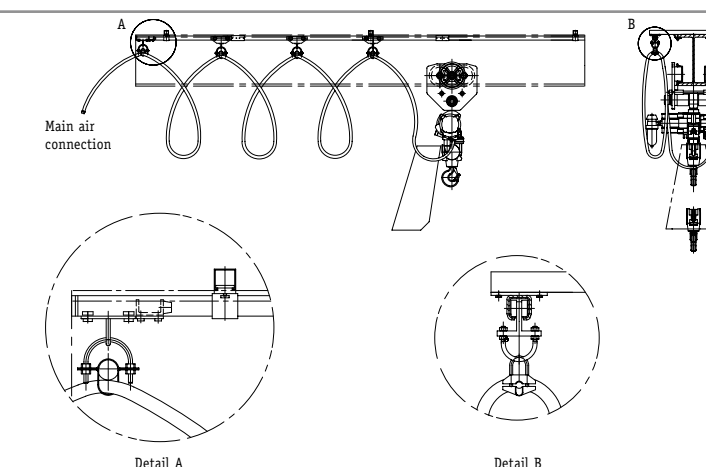
Depending on the local conditions, rails and curved tracks of different lengths are available, as well as an extensive range of installation accessories. The square bar is also suitable for curved tracks.

- Consisting of: Square bars, tensioning arms, hose, hose supports and supply line carriages



## C rail

- Consisting of: Consisting of: C rails with support, adapter, antistatic supply hose and hose support. The supports must be attached to the upper flange of the beam.







---

Weighing and  
Measurement Devices

221

## EDjunior Dynamometer

Lifting the bar in electronic dynamometers

### Big on the basics

The EDjunior dynamometer gets straight to the point – apply a load; take a reading. Its Spartan design is a direct response to industries that have wanted an extremely well-built instrument that could be relied upon for simple, yet critical measurements of weight and force.

### A Strong Family Resemblance

The EDjunior draws its strength from the exhaustive engineering that went into the design of the Dillon EDXtreme dynamometer. Both share the same base of research and testing to match material characteristics and load cell technology. The choices made in development have yielded an exceptionally rugged instrument capable of consistently delivering accurate, repeatable measurements.

### Extreme Value

The EDjunior is even more remarkable, when you consider price. If you believe you have to pay more, to get more – just compare the Dillon EDjunior to the competition. Nothing else comes close!

5,000 lb capacity EDjunior shown.

EDjunior dynamometers are available in capacities up to 25,000 lbf (10,000 kgf).

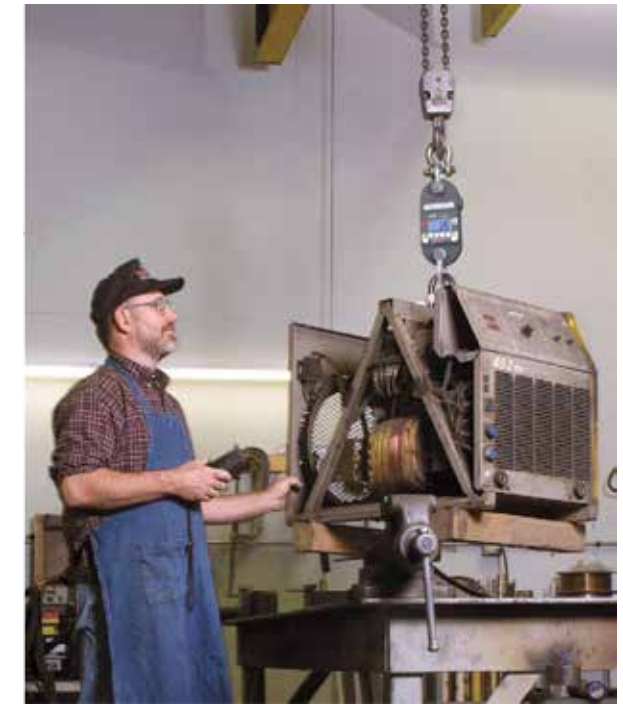
**DILLON**  
Force Measurement Equipment



CE

## Proof of Performance

The EDjunior is all about value. Behind its simple design and easy operation, you will find the quality and performance not found elsewhere in the low price range. With the EDjunior, Dillon proves that economy can go hand-in-hand with accuracy, long service life and, most importantly, worker safety.



### Consider the features; compare the numbers:

#### Measurement Capabilities

The EDjunior provides peak detection as well as sustained load readings. Selectable units of measure include lbf, kgf and Newtons.

- **Accuracy** — The load element design and strain gauges chosen for the EDjunior produce an accuracy of 0.2 % (full scale). This level of precision offers flexibility for use in a broad range of applications.
- **Resolution** — Readings are displayed with a resolution of 1 part in 1000 to ensure the level of readability required for critical lifting applications.

#### Control Interface

The exclusive Dillon SOFTKEY interface provides direct access to setup and display functions without the typical confusing menu structure. The 6-digit dot-matrix display features 1 inch (26 mm) high numerals for greater visibility.

#### High Strength, Low Weight

Heavy, cumbersome tools make tough jobs even harder. Through the use of aircraft quality materials, Dillon has made the EDjunior an easy-to-position, highly mobile instrument with exceptional strength. It offers an impressive factor of safety at all capacities.

Dillon's distinctive curve-body design further eliminates unnecessary weight and streamlines the unit to help prevent binding.

#### Battery Operation

Power is supplied by two C-cell batteries that are easily accessible through a side-loading port. Battery replacement, however, is a rare event. With the EDjunior's low power consumption, typical battery life is over 425 hours.

#### All Environments

With its NEMA4/IP55 design, the EDjunior is at home in virtually any environment and ideally-suited to exterior job-site applications as well as in-plant use.

#### Backlight

When in a low light area, turn on the configurable backlight to make readings highly visible.

#### Standard Accessories

Cases for secure transportation and storage of instruments and shackles.

*Specifications and dimensional details are available from an authorized Dillon Distributor or the website at [www.dillonforce.com](http://www.dillonforce.com).*

*Dillon also manufactures highly accurate mechanical dynamometers and crane scales, as well as the EDXtreme, a full featured, precision electronic dynamometer with radio communications capability (right).*



Low capacity model – 2,500 lbf / 1000 kgf

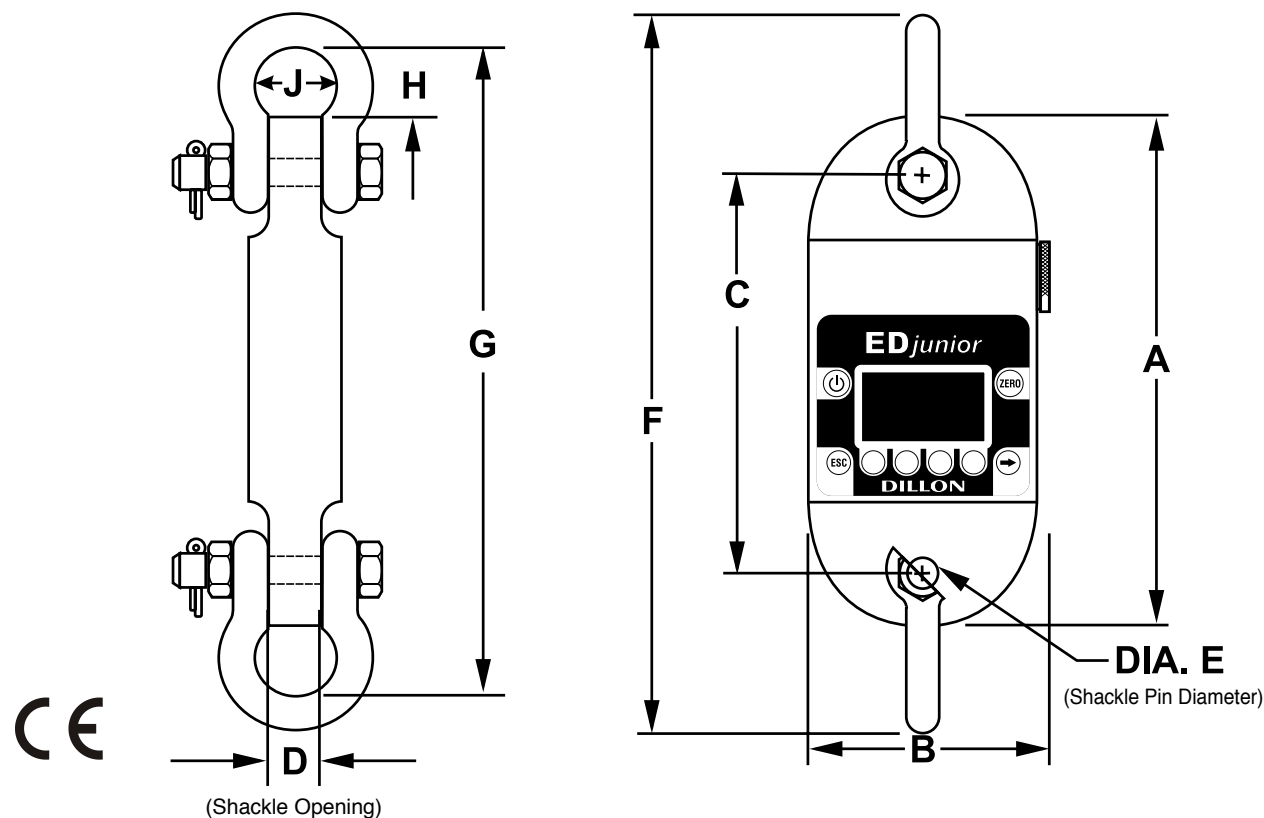


### EDjunior Dynamometer Specifications

| Capacity x Resolution      |                 |                 |                 | Body Construction and Overload Design                               |
|----------------------------|-----------------|-----------------|-----------------|---|
| <b>EDjr-1T</b> (EDjr-2.5K) | 2,500 lbf x 2   | 1,000 kgf x 1   | 10,000 N x 10   | Aircraft quality 2024 Aluminum<br>700% Ultimate overload protection |
| <b>EDjr-2T</b> (EDjr-5K)   | 5,000 lbf x 5   | 2,000 kgf x 2   | 20,000 N x 20   |   |
| <b>EDjr-5T</b> (EDjr-10K)  | 10,000 lbf x 10 | 5,000 kgf x 5   | 50,000 N x 50   | E4340 Alloy Steel<br>500% Ultimate overload protection              |
| <b>EDjr-10T</b> (EDjr-25K) | 25,000 lbf x 20 | 10,000 kgf x 10 | 100,000 N x 100 |   |

Note: Model in parenthesis shows U.S. convention for describing capacities.

| Dimensions <i>Dimensions shown are nominal and subject to tolerances</i> |            |             |            |            |            |            |             |             |            |             |            |
|--|------------|-------------|------------|------------|------------|------------|-------------|-------------|------------|-------------|------------|
| Model  |            | A           | B          | C          | D          | E          | F           | G           | H          | I           | J          |
| <b>EDjr-1T</b>   | inch<br>mm | 8.4<br>213  | 5.0<br>127 | 6.9<br>174 | 0.75<br>19 | 0.50<br>13 | 11.6<br>296 | 10.8<br>274 | 1.20<br>30 | 2.03<br>52  | 1.16<br>29 |
| <b>EDjr-2T</b>   | inch<br>mm | 10.6<br>269 | 5.0<br>127 | 7.8<br>198 | 1.06<br>27 | 0.75<br>19 | 14.8<br>375 | 13.4<br>340 | 1.41<br>35 | 2.94<br>75  | 1.69<br>43 |
| <b>EDjr-5T</b>   | inch<br>mm | 11.4<br>289 | 5.3<br>135 | 8.1<br>206 | 1.38<br>35 | 1.00<br>25 | 17.8<br>451 | 15.8<br>402 | 2.22<br>56 | 4.03<br>102 | 2.28<br>58 |
| <b>EDjr-10T</b>  | inch<br>mm | 11.5<br>291 | 5.3<br>133 | 7.9<br>201 | 1.97<br>50 | 1.38<br>35 | 21.6<br>548 | 18.8<br>478 | 3.67<br>93 | 4.53<br>115 | 3.25<br>83 |



### Dillon EDXtreme

Guesswork is not acceptable – failure is not an option. When you have people working around high tension cables and massive loads, there is no room for error. You have to have complete confidence in the strength and the accuracy of your measurement tools.

Since 1937, Dillon Dynamometers have been chosen for the jobs where only the best will do. Now, Dillon has once again lifted the performance bar and set the standard for others to follow.

#### Features

- Dramatically improved battery life in the EDXtreme link
- Dramatically improved radio communications distance
- High speed Peak Capture 10/100/1,000 Hz
- Improved backlight intensity
- Lift and store of weight / force
- Date and time
- Continuous data storage
- Re-calibration reminder
- Can communicate with two Communicators via radio
- Overload at 120% with date and time record

#### Uncompromising on safety and adaptable to the need

The EDXtreme exemplifies the trademark precision and rugged construction of Dillon dynamometers. Its highly refined design draws on the inherent strengths of premium grade materials to achieve a 5:1 minimum factor of safety.\*

While the EDXtreme may be configured for something as simple as a digital hanging scale, it offers a higher level of intelligence. With user-defined functions and sophisticated communication options, the EDXtreme readily adapts to multi-tasking operations or multi-link systems capable of monitoring a series of critical stress points from a single location — it is the definition of application versatility.

\* Models with 75 T/160,000 lb or higher capacity feature a 4:1 safety factor and 0.3% accuracy.

Models available in capacities from 2500 to 550,000 lbf (1000 to 250,000 kgf).





## For the toughest jobs you face

### Xtreme engineering

Building a precision instrument that can survive real-world punishment requires masterful engineering. This is where Dillon's experience shines through. The engineers assigned to the EDXtreme drew on a depth of industrial application knowledge and conducted exhaustive materials testing to achieve the highest structural integrity.

- **Superior strength and corrosion resistance**  
High capacity models are constructed of powder coated aircraft-quality alloy steel. Lower capacity models are powder coated aircraft-quality aluminum.
- **5:1 factor of safety\***  
This measure of strength and safety is maintained at all capacities. Computer modeling confirms the low stress and long product life that is inherent in the EDXtreme design.
- **Retained hardware**  
Allows permanent attachment of centering spacers, which eliminates fumbling during high capacity rigging.
- **NEMA 4X/IP55**  
The EDXtreme is clearly the choice for reliability in any environment – in-plant or out on the job site.

\* Models with 75 T/160,000 lb or higher capacity feature a 4:1 safety factor and 0.3% accuracy.

### Xtreme accuracy: 0.1%

High resolution and accurate repeatable readings are essential to proper weighing. The higher standards set for the EDXtreme meant taking the time to ensure that material characteristics, load element design and strain gauge meshed perfectly. The result of that effort is a typical accuracy of 0.1% of full scale capacity\*. The enhanced resolution mode of 1 part in 5000 provides the level of readability needed for refined weighing.

### Xtreme ease

- **Exclusive SOFTKEY interface** – Dillon has eliminated confusing menus for faster setup and simple operation. In addition to lbf, kgf and Newtons, programmable functions can correct for gravitational variations and allow the use of custom units of measurement.
- **Wide-angle, backlit LCD** – Provides improved readability over a wider viewing angle and has backlighting for low light conditions.
- **Battery operation** – The EDXtreme is powered by two standard C-cell batteries. Batteries are easily accessible for fast replacement.

### Configuration options

A basic stand-alone model can be easily upgraded "in-the-field" to accommodate changing needs. Remote configuration, data acquisition and single point monitoring of multiple links are all possible with the hardwired or radio communication options available with the EDXtreme. An RS-232 interface is standard on both the EDXtreme and Communicator for connection to a host PC.

#### Typical Configurations

1. Stand-alone EDx for direct measurement applications.
2. Single network with one EDx radio dynamometer and Communicator.
3. Single network with multiple EDx dynamometers and one Communicator. The Communicator monitors the load at each scale, plus the total weight.
4. Single network with two, three or four Communicators.
5. Multiple networks with multiple EDx dynamometers and Communicators.



Plant airspace Discrete radio channel

Optional Remote Communicator II



## EDXtreme Dynamometer Specifications

### Capacity & Resolution

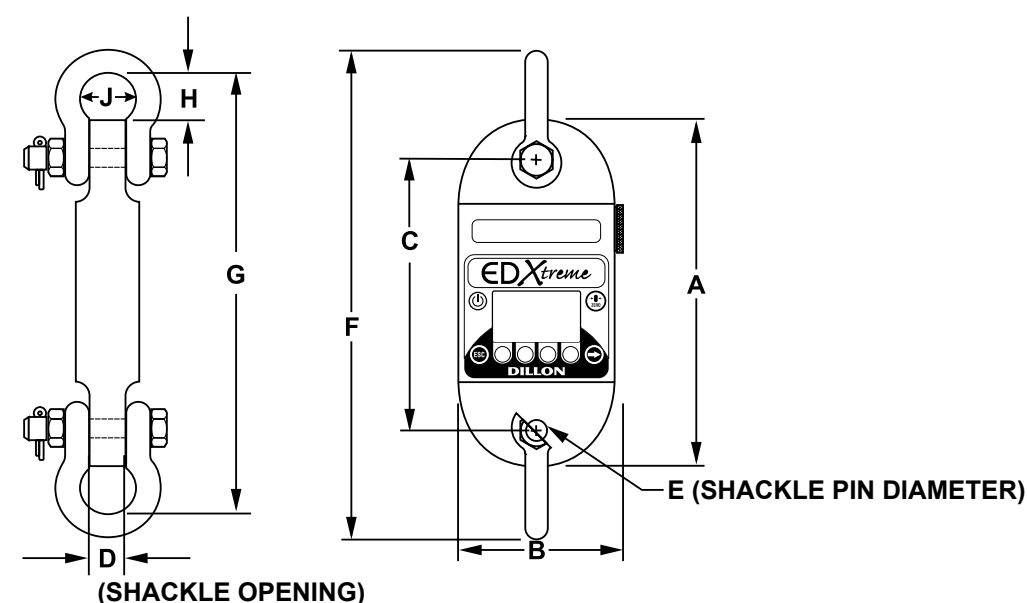
| Model*                     | Capacity x Resolution (normal/enhanced) |                      |                     | Overload† | Construction                       |
|----------------------------|---|----------------------|---------------------|-----------|------------------------------------|
| <b>EDx-1T</b> (EDx-2.5K)   | 2,500 lbf x 2/0.5                       | 1,000 kgf x 1/0.2    | 10,000 N x 10/2     |           |                                    |
| <b>EDx-2T</b> (EDx-5K)     | 5,000 lbf x 5/1                         | 2,000 kgf x 2/0.5    | 20,000 N x 20/5     | 700%      | Aircraft-quality 2024 aluminum     |
| <b>EDx-5T</b> (EDx-10K)    | 10,000 lbf x 10/2                       | 5,000 kgf x 5/1      | 50,000 N x 50/10    |           |                                    |
| <b>EDjr-2T</b> (EDjr-5K)   | 25,000 lbf x 20/5                       | 10,000 kgf x 10/2    | 100,000 N x 100/20  |           |                                    |
| <b>EDx-10T</b> (EDx-25K)   | 55,000 lbf x 50/10                      | 25,000 kgf x 20/5    | 250,000 N x 200/50  | 500%      | Aircraft-quality E4340 alloy steel |
| <b>EDx-25T</b> (EDx-55K)   | 100,000 lbf x 100/20                    | 50,000 kgf x 50/10   | 500,000 N x 500/100 |           |                                    |
| <b>EDx-50T</b> (EDx-100K)  | 160,000 lbf x 100/50                    | 75,000 kgf x 50/20   | -                   |           |                                    |
| <b>EDx-100T</b> (EDx-220K) | 220,000 lbf x 200/50                    | 100,000 kgf x 100/20 | -                   |           |                                    |
| <b>EDx-150T</b> (EDx-330K) | 330,000 lbf x 200/100                   | 150,000 kgf x 100/50 | -                   | 400%      | Aircraft-quality E4340 alloy steel |
| <b>EDx-250T</b> (EDx-550K) | 550,000 lbf x 500/200                   | 250,000 kgf x 200/50 | -                   |           |                                    |

\*Model number in parenthesis shows U.S. convention for describing capacities. †Ultimate overload protection rating.

### Dimensions inches (mm)

| Model           | A          | B         | C          | D          | E          | F           | G           | H           | J          | Shackle    |
|-----------------|------------|-----------|------------|------------|------------|-------------|-------------|-------------|------------|------------|
| <b>EDx-1T</b>   | 10.6 (269) | 5.0 (127) | 7.8 (198)  | 1.06 (26)  | 0.75 (19)  | 15.3 (389)  | 13.4 (340)  | 1.36 (34)   | 1.69 (43)  | Dillon     |
| <b>EDx-2T</b>   | 10.6 (269) | 5.0 (127) | 7.8 (198)  | 1.06 (26)  | 0.75 (19)  | 15.3 (389)  | 13.4 (340)  | 1.36 (34)   | 1.69 (43)  | Dillon     |
| <b>EDx-5T</b>   | 11.4 (289) | 5.3 (135) | 8.1 (206)  | 1.46 (37)  | 1.00 (25)  | 17.5 (444)  | 15.7 (400)  | 2.17 (55)   | 2.28 (58)  | Green Pin* |
| <b>EDx-10T</b>  | 11.5 (291) | 5.3 (133) | 7.9 (201)  | 2.01 (51)  | 1.38 (35)  | 21.0 (534)  | 18.5 (470)  | 3.50 (89)   | 3.25 (83)  | Green Pin* |
| <b>EDx-25T</b>  | 13.7 (348) | 6.0 (152) | 9.0 (229)  | 2.91 (74)  | 1.97 (50)  | 28.7 (730)  | 25.2 (640)  | 5.70 (146)  | 4.96 (126) | Green Pin* |
| <b>EDx-50T</b>  | 15.8 (400) | 6.8 (172) | 10.3 (262) | 4.13 (105) | 2.75 (70)  | 38.8 (986)  | 33.7 (856)  | 8.98 (228)  | 7.09 (180) | Green Pin* |
| <b>EDx-75T</b>  | 16.5 (419) | 7.8 (197) | 10.3 (262) | 4.13 (105) | 2.75 (70)  | 39.3 (998)  | 33.7 (856)  | 8.58 (218)  | 7.09 (180) | Green Pin* |
| <b>EDx-100T</b> | 18.0 (457) | 7.8 (197) | 11.0 (280) | 5.00 (127) | 3.25 (83)  | 46.9 (1191) | 40.4 (1025) | 11.14 (283) | 7.48 (190) | Green Pin* |
| <b>EDx-150T</b> | 21.0 (533) | 8.8 (222) | 12.6 (321) | 5.25 (133) | 3.75 (95)  | 53.9 (1368) | 45.6 (1159) | 12.3 (313)  | 9.0 (229)  | Crosby     |
| <b>EDx-250T</b> | 27.0 (686) | 9.8 (248) | 17.5 (445) | 8.5 (216)  | 5.00 (127) | 75.8 (1925) | 62.8 (1595) | 17.9 (454)  | 13.0 (330) | Crosby     |

\*Dimensions using Green Pin shackles. Crosby shackles available. Consult factory for dimensions. Dimensions shown are nominal and subject to tolerances.





### Dynamometer Specifications

**Enclosure:** Designed to NEMA4X/IP55. Suitable for continuous outdoor use.

**Accuracy:** 0.1% of capacity up to EDx-50T.\*  
0.3% of capacity for EDx-75T and above.\*

**Repeatability:** 0.1% of capacity up to EDx-50T.\*  
0.3% of capacity for EDx-75T and above.\*

\*Normal resolution mode with Dillon provided shackles.

**Proof Load:** 150% of capacity up to EDx-75T.  
110% of capacity EDx-100T and above.

**Ultimate Overload:** See table on reverse.

**Safe Overload:** 200% of capacity

**Body Protection:** Aluminum and alloy steel capacities are powder coated.

**Bearings:** Unmatched repeatability attained by needle bearings in shackle pin holes up to EDx-5T. Shackle pin acts as inner race.

**Shackles:** Forged industry standard anchor shackles. Models up to EDx-5T use precision machined shackle pin. Higher capacities use bar stock pin.

**Display:** 128 x 64 dot-graphic LCD display shows up to 6 digits 1.0" (26 mm) high plus annunciators and softkeys. Digits are .11 inches (3 mm) thick for unmatched readability.

**Display Update Rate:** 2 times per second.

**Peak Capture Rate:** 10/100/1,000 Hz

**Connector:** Recessed sealed connector may be used for serial communications or connection to a Communicator II remote.

**RS-232**

**Communication:** Print or extract data easily. Continuous output can drive a scoreboard. Configurable poll character.

**Calibration:** Traceable to the National Institute of Standards and Technology. Certificate included with curve of readings. Passes only with three consecutive confirming runs, with all points in specification.

**Battery Life:** Stand alone EDxtreme with no radio and no backlight lasts up to 400+ hours. 150 hours continuous with Radio Link System. Use with two C-Cell alkaline batteries. (When using backlight, battery life will be reduced, depending on intensity.)

**Operating Temperature:** -4° F to 158° F (-20° to 70° C)

**Included with**

**Instrument:** All include certificate of calibration, manual and batteries. Plastic carry case included for EDx-1T to EDx-50T. Higher capacities include rugged plywood storage crate. Instruments with shackles include centering spacers (EDx-20T & up) and shackle storage crate (EDx-20T to EDx-75T). Display backlight.

**Options:** Shackles. Radio communications.

**Approval:** CE

### Dynamometer Specifications

**Enclosure:** Designed to NEMA 3 / IP54 with optional sleeve. Suitable for protected outdoor use.

**Instrument Size:** 9.5 x 5.0 x 2.5 inch (241 x 127 x 64mm).

**Accuracy:** Not applicable. Only sends and receives digital information.

**Display:** 128 x 64 dot-graphic LCD display can show full readings up to 5 instruments.

**Battery Life:** Up to 80 hours continuous radio using (4) AA alkaline batteries.

**Operating Temperature:** -4° F to 158° F (-20° to 70° C)

**Connectors:** Sealed connectors may be used for serial communications and wired connection to an EDxtreme dynamometer.

**RS-232**

**Communication:** Print or extract data easily. Continuous output can drive a scoreboard. Configurable poll character.

**Included with Remote:** Carry case and batteries

**Accessories:** Rubberized case protector sleeve.  
Remote wall mount bracket.  
Serial and remote cable assemblies.

**Approval:** CE

### Dynamometer Specifications

**FCC Certified:** For unlicensed low power devices. No radio licensing or permits required for normal operation.  
\*(In the US and Canada. Check local ordinances in other countries.)

**Frequency:** ISM 2.4 GHz frequency band operates between 2.4 to 2.4835 GHz.

**Output Level:** 10 mW (10 dBm)

**Display Update Rate:** 1 time per second.

**Number of Links Remote Can Control:** Up to 15 addresses.

**Configuration Address:** Automatic and configurable.

**Antenna:** Integral antenna.

**Range:** Open-air range up to 600 feet, line-of-sight. Indoor range dependent upon environment with 300 feet common. Low power radio systems are dependent upon interference levels from other radio systems and environmental conditions. Radio devices are not suitable for all applications.

### Weights pounds (kg)

| Model        | Unit Weight  | Weight with Shackles | Approximate Shipping Weight |
|--------------|--------------|----------------------|-----------------------------|
| EDx-1T       | 4.3<br>(2.0) | 8.6<br>(3.9)         | 13<br>(6)                   |
| EDx-2T       | 4.4<br>(2.0) | 8.7<br>(3.9)         | 13<br>(6)                   |
| EDx-5T       | 5.6<br>(2.5) | 14<br>(6)            | 22<br>(10)                  |
| EDx-10T      | 16<br>(7.3)  | 38<br>(17)           | 44<br>(20)                  |
| EDx-25T      | 25<br>(11)   | 91<br>(41)           | 120<br>(54)                 |
| EDx-50T      | 38<br>(17)   | 216<br>(98)          | 274<br>(124)                |
| EDx-75T      | 54<br>(25)   | 229<br>(104)         | 304<br>(138)                |
| EDx-100T     | 70<br>(32)   | 395<br>(179)         | 465<br>(211)                |
| EDx-150T     | 120<br>(54)  | 650<br>(295)         | 750<br>(340)                |
| EDx-250T     | 250<br>(113) | 1,490<br>(675)       | 1,600<br>(725)              |
| Communicator | 1.25<br>(.6) | -                    | 10<br>(5)                   |

## AP Crane Scale Hardware Kits

Proven reliability and performance



**DILLON**  
Force Measurement Equipment



## Model AP Mechanical Crane Scale Hardware Kits

### Features and Benefits

- **Available in Low, Intermediate and High Range Models:** Capacities from 1000 to 20,000 pounds. Capacities from 500 to 10,000 kg.
- **Anti-Parallax Dial and Pointer:** Easy to read even at an angle.
- **Tare Capability:** Tare loads up to 20% of capacity can be zeroed out by means of zero control.
- **Dust Protection:** Pinion gear, sector gear and shafts are mounted in precision aircraft bearings, permanently sealed against dust and dirt. Oiling is never required.
- **Tough Construction:** Mechanism case is a heavy aluminum alloy casting, tough enough to resist even heavy blows.
- **Ingenious Design:** Utilizes a specially designed alloy steel beam that translates force to pounds. Full scale reading results from beam deflection of only 0.026. Applied loads are indicated instantly.
- **Reduced Wear:** Pinion and sector gears are cut from stainless steel and hardened aluminum. Use of these dissimilar materials greatly reduces friction and wear.
- **Protective Finish:** Scale cases are coated with a baked-on powder paint process making them resistant to chips, scratches, rust and corrosion.
- **Maximum Indicator:** Remains in position to indicate peak load point after load is removed from scale.
- **Hook Kits:** Now offered as an add on feature to the AP Dynamometer of choice.

### Specifications

| Capacity | Capacities & Dial Divisions (kg) | Capacities & Dial Divisions (lb) | Length (cm) | Dynamometer  |               | Hook Kit     |               | Crate Dimensions (cm) |
|----------|----------------------------------|----------------------------------|-------------|--------------|---------------|--------------|---------------|-----------------------|
|          |                                  |                                  |             | Net Wt. (kg) | Ship Wt. (kg) | Net Wt. (kg) | Ship Wt. (kg) |                       |
| Low      | 500 x 2                          | 1,000 x 5                        | 64.8        | 4.5          | 7             | 6            | 20            | 35.6 x 73.7 x 27.9    |
| Low      | 1,000 x 5                        | 2,000 x 10                       | 64.8        | 4.5          | 7             | 6            | 20            | 35.6 x 73.7 x 27.9    |
| Low      | 2,000 x 10                       | N/A                              | 64.8        | 4.5          | 7             | 6            | 20            | 35.6 x 73.7 x 27.9    |
| Low      | N/A                              | 5,000 x 20                       | 64.8        | 4.5          | 7             | 6            | 30            | 35.6 x 73.7 x 27.9    |
| Low      | 5,000 x 20                       | 10,000 x 50                      | 64.8        | 4.5          | 7             | 9            | 30            | 35.6 x 73.7 x 27.9    |
| Med      | *10,000 x 50                     | *20,000 x 100                    | 75.6        | 4.5          | 7             | 19           | 35            | 35.6 x 73.7 x 27.9    |

**Accuracy:** To  $\pm 0.5\%$  of full scale

**Tare Adjustment:** Up to 20% of full scale range

**Ultimate Safety Factor:**

5:1

\*4:1 for 20,000 lb, 10000 kg

All kits are shipped complete to allow direct interface to the AP Dynamometer.

Hook kits are shipped in separate packaging.

**Dial Diameter:** 10"

**Scale Length:** (from inside of eye to inside of hook)

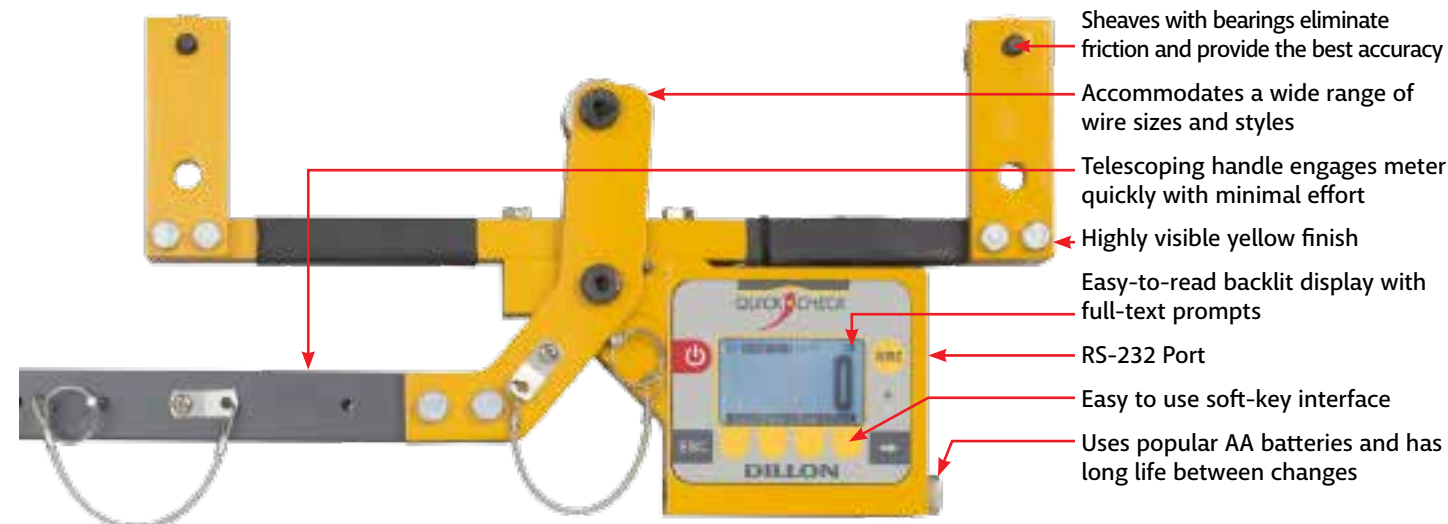
Low Range: 64.8 cm (25½")

Intermediate Range: 75.6 cm (29¾")

High Range: 95.3 cm (37½")

**Approval:** CE

**Warranty:** 2 years parts and labor



- Sheaves with bearings eliminate friction and provide the best accuracy
- Accommodates a wide range of wire sizes and styles
- Telescoping handle engages meter quickly with minimal effort
- Highly visible yellow finish
- Easy-to-read backlit display with full-text prompts
- RS-232 Port
- Easy to use soft-key interface
- Uses popular AA batteries and has long life between changes

### The Fastest Cable Tension Meter

The Dillon Quick-Check can be placed on a cable, measure its tension, and removed in under five seconds! There are no complex lookup tables, no conversion charts. The operator can quickly select from 20 different wire sizes and types stored in Quick-Check's memory. The Check-Tensioning mode graphically displays the current and target tensions for extremely quick setting of line tension. Even the infrequent battery changes are quick.

### Broad Application

The Quick-Check can be employed in many industries to ensure proper tensioning. Typical applications include tower and stack guy wires, pretensioned cable barriers, bridges, elevators, winch rope, overhead electric transit wires, fall arrest systems, aircraft cables and utilities.

### Specifications

**Tension capacities:**  
2000 lb/10 kN/1000 kg  
10,000 lb/45 kN/4500 kg

**Wire sizes:**  
3/16 inch through 1 inch  
(4.75 mm through 25.4 mm)  
View helpful ordering tips at [dillon-force.com](http://dillon-force.com)

**Accuracy:** + 3% instrument capacity (calibrated to specific wire size and type.)

**Loading error:** Cable elongation of only 0.08 inch (2mm)

**Display:** Dot-graphic LCD display supports full text and 1 inch high digits.

**Sheave range:** Each set accommodates rated wire size and ½" smaller. Multiple sheave sets may be used.

**Suggested wire calibrations:** Calibrate each wire diameter needed with the most appropriate sheaves. If two wire types are used of the same diameter (e.g. ½" 1x7 and ½" 6x19), calibrate each type independently if accuracy is critical.

**Environment protection:**  
Suitable for continued outdoor use.

**Operating range:**  
-4° F to 158° F (-20° C to 70° C)

**Tension units of measure:**  
pound-force, kilogram force, Newtons

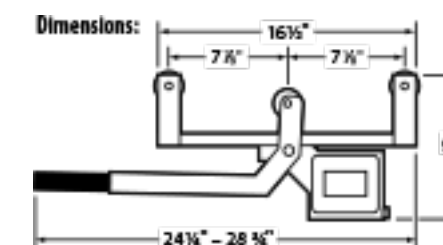
**Resolution:** Configurable low/med/high

**Size:** 10 x 23 x 3 inch (25 x 59 x 8 cm)

**Weight:** Approx 11 lb (5 kg)

**Recalibration:** At user discretion. Commonly 12-24 months; should be more frequent with heavy use. On-site recalibration may be possible through your Dillon distributor.

**Approvals:** CE



RS-232 port



Carry case included



Dillon also manufactures highly accurate electronic and mechanical dynamometers and crane scales.







---

Material  
Handling Range

233

GS series is a suitable practical solution meeting all the needs of manual handling.

For the transport of fragile and delicate loads, such as loads of glass or ceramics, the premium version includes a sensitive and safe forks lowering control system. The special series, with its broad choice of forks dimensions, guarantees solutions to handle any type of pallet; finally, the pro version, also available with a 3.000 Kg load capacity, completes the range of Lifter pallet trucks that are completely made in Italy.

**GS Basic**

The GS basic pallet truck is the model of access to the range of Lifter hand pallet trucks with which it shares reliability and solidity. Available with fork length 800 and 1150 mm.

**GS Premium**

The GS premium pallet truck offers innovative cutting-edge solutions, such as the tilt guide wheel, the load lowering speed control, the covered steering wheel, apart from a certified hydraulic unit for 50.000 Cycles.

**GS Pro, Special 3 ton**

The GS pro pallet truck is equipped as a standard with a start and exit roller and a more ergonomic handle. The special series allows for the handling of pallets of any size thanks to the great variety of frames. The new 3.000 Kg model offers a load capacity of 3.000 Kilograms thanks to its reinforced structure.



Available accessories: tandem rollers, polyurethane rollers (as a standard on Premium), rubber guide wheels, manual control brake



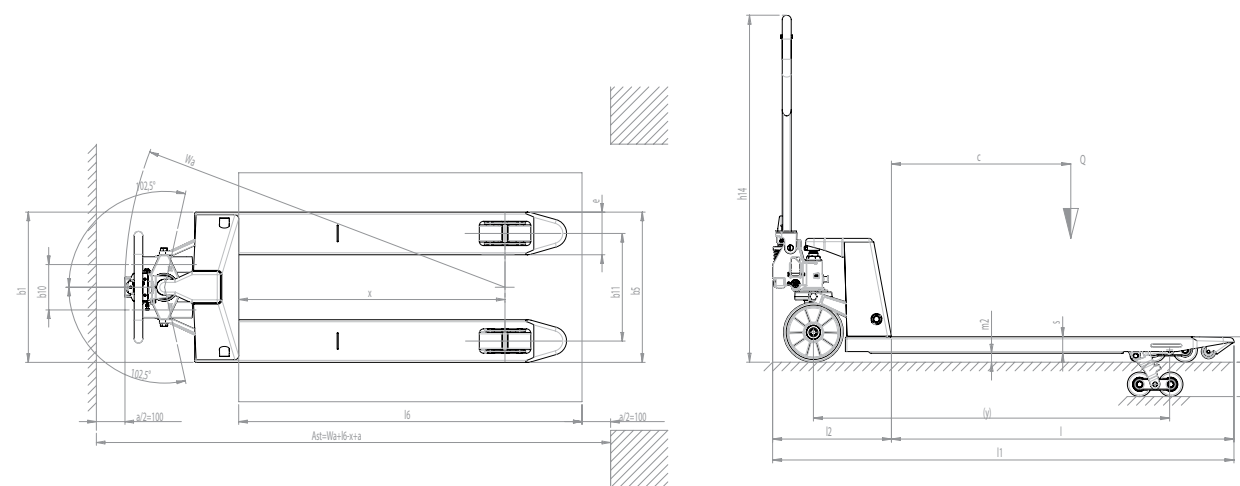
**Maximum Pressure Valve**

When the maximum load capacity is exceeded, oil pressure exceeds its maximum limit and the valve automatically locks the forks. Thus possible structural damage is avoided.



**Painting**

Following an appropriate conditioning operation the frame is varnished with epoxy-polyester powder at a temperature of 250° to guarantee maximum resistance to wear and atmospheric agents.



| DESCRIPTION             |   |       |                   |                 |                     |                    |               |                   |                   |               |
|-------------------------|---|-------|-------------------|-----------------|---------------------|--------------------|---------------|-------------------|-------------------|---------------|
| 1.2                     | MODEL                                       |       | GS BASIC 22 S2-S4 | GS PRO 25 S2-S4 | GS PREMIUM 25 S2-S4 | GS/AV PRO 25 S2-S4 | GS PRO 30 S4  | GS/L PRO 25 S2-S4 | GS/M PRO 25 S2-S4 | GS B 20 S4    |
| 1.3                     | DRIVE                                       |       | MANUAL            | MANUAL          | MANUAL              | MANUAL             | MANUAL        | MANUAL            | MANUAL            | MANUAL        |
| 1.4                     | OPERATOR TYPE                               |       | PEDESTRIAN        | PEDESTRIAN      | PEDESTRIAN          | PEDESTRIAN         | PEDESTRIAN    | PEDESTRIAN        | PEDESTRIAN        | PEDESTRIAN    |
| 1.5                     | LOAD CAPACITY                               | Q     | kg                | 2200            | 2500                | 2500               | 2500          | 3000              | 2500              | 2500          |
| 1.6                     | LOAD CENTRE DISTANCE                        | c     | mm                | 600             | 600                 | 600                | 600           | 600               | 400               | 600           |
| 1.8                     | LOAD DISTANCE, CENTRE OF DRIVE AXLE TO FORK | x     | mm                | 932             | 932                 | 932                | 932           | 932               | 932               | 945           |
| 1.9                     | WHEEL BASE                                  | y     | mm                | 1192            | 1192                | 1192               | 1192          | 1192              | 842               | 1192          |
| <b>WEIGHTS</b>          |   |       |                   |                 |                     |                    |               |                   |                   |               |
| 2.1                     | SERVICE WEIGHT                              |       | kg                | 61-63           | 61-63               | 63-65              | 61-63         | 79                | 66-68             | 52-54         |
| 2.2                     | AXLE LOAD LADEN, FRONT/REAR                 |       | kg                | 655/1606-1608   | 767/1794-1796       | 739/1824-1826      | 738/1823-1825 | 889/2190          | 771/1795-1797     | 691/1861-1863 |
| 2.3                     | AXLE LOAD UNLADEN, FRONT/REAR               |       | kg                | 42/19-21        | 42/19-21            | 43/20-22           | 42/19-21      | 53/26             | 46/20-22          | 35/17-19      |
| <b>TYRES/CHASSIS</b>    |   |       |                   |                 |                     |                    |               |                   |                   |               |
| 3.1                     | TYRES                                       |       |                   | P/N             | P/N                 | P/P                | P/N           | P/N               | P/N               | P/A           |
| 3.2                     | TYRE SIZE, FRONT (Ø x width)                |       |                   | 200x45          | 200x55              | 200x55             | 200x55        | 200x55            | 200x55            | 200x55        |
| 3.3                     | TYRE SIZE, REAR (Ø x width)                 |       |                   | 82x82-60        | 82x82-60            | 82x82-60           | 82x82-60      | 82x60             | 82x82-60          | 82x82-60      |
| 3.4                     | SIDE WHEELS (Ø x width)                     |       |                   | -               | -                   | -                  | -             | -                 | -                 | -             |
| 3.5                     | WHEELS, NUMBER (x=DRIVEN) FRONT/REAR        |       |                   | 2/2-2/4         | 2/2-2/4             | 2/2-2/4            | 2/2-2/4       | 2/4               | 2/2-2/4           | 2/4           |
| 3.6                     | TREAD, FRONT                                | b10   | mm                | 155             | 155                 | 155                | 155           | 155               | 155               | 130           |
| 3.7                     | TREAD, REAR                                 | b11   | mm                | 375             | 375                 | 375                | 375           | 375               | 535               | 250           |
| <b>DIMENSIONS</b>       |   |       |                   |                 |                     |                    |               |                   |                   |               |
| 4.4                     | LIFT  | h3    | mm                | 115             | 115                 | 115                | 115           | 115               | 115               | 115           |
| 4.9                     | HEIGHT OF TILLER IN DRIVE POSITION MIN/MAX  | h14   | mm                | 690/1160        | 690/1160            | 690/1160           | 415/1250      | 690/1160          | 690/1160          | 690/1160      |
| 4.15                    | HEIGHT, LOWERED                             | h13   | mm                | 85              | 85                  | 85                 | 85            | 85                | 85                | 55            |
| 4.19                    | OVERALL LENGTH                              | l1    | mm                | 1550            | 1550                | 1550               | 1550          | 1550              | 1550              | 1200          |
| 4.20                    | LENGTH TO FACE OF FORKS                     | l2    | mm                | 400             | 400                 | 400                | 400           | 400               | 400               | 400           |
| 4.21                    | OVERALL WIDTH                               | b1    | mm                | 525             | 525                 | 525                | 525           | 525               | 685               | 400           |
| 4.22                    | FORK DIMENSIONS                             | s/e/l | mm                | 55/150/1150     | 55/150/1150         | 55/150/1150        | 55/150/1150   | 55/150/1150       | 55/150/1150       | 55/150/800    |
| 4.25                    | DISTANCE BETWEEN FORK ARMS                  | b5    | mm                | 525             | 525                 | 525                | 525           | 525               | 685               | 400           |
| 4.32                    | GROUND CLEARANCE, CENTRE OF WHEEL BASE      | m2    | mm                | 30              | 30                  | 30                 | 30            | 30                | 30                | 15            |
| 4.34                    | ASLE WIDTH FOR PALLET 800x1200 LENGTHWISE   | Ast   | mm                | 1835            | 1835                | 1835               | 1835          | 1835              | 1835              | 1435          |
| 4.35                    | TURNING RADIUS                              | Wa    | mm                | 1367            | 1367                | 1367               | 1367          | 1367              | 1367              | 1017          |
| <b>PERFORMANCE DATA</b> |   |       |                   |                 |                     |                    |               |                   |                   |               |
| 5.2                     | LIFT SPEED, LADEN/UNLADEN                   |       | strokes           | 13/13           | 13/13               | 13/13              | 13/6          | 13/13             | 13/13             | 13/13         |

G = Rubber, N = Nylon, P = Polyurethane, A = Steel, NE = Nylon extra

|   |    |    |               |               |               |               |               |               |          |          |           |           |
|---|----|----|---------------|---------------|---------------|---------------|---------------|---------------|----------|----------|-----------|-----------|
| FORK LENGTH                                 | l  | mm | 600           | 800           | 950           | 1000          | 1150          | 1220          | 1350     | 1500     | 1800      | 2000      |
| LOAD CENTRE DISTANCE                        | c  | mm | 300           | 400           | 475           | 500           | 600           | 610           | 675      | 750      | 900       | 1000      |
| WHEELS, NUMBER (x=DRIVEN) FRONT/REAR        |    |    | 2/2-2/4       | 2/2-2/4       | 2/2-2/4       | 2/2-2/4       | 2/2-2/4       | 2/2-2/4       | 2/4      | 2/4      | 2/4       | 2/4       |
| OVERALL LENGTH                              | l1 | mm | 1000          | 1200          | 1350          | 1400          | 1550          | 1620          | 1750     | 1900     | 2200      | 2400      |
| LOAD DISTANCE, CENTRE OF DRIVE AXLE TO FORK | x  | mm | 382           | 582           | 732           | 782           | 932           | 1002          | 1132     | 1282     | 1582      | 1782      |
| WHEEL BASE                                  | y  | mm | 642           | 842           | 992           | 1042          | 1192          | 1262          | 1392     | 1542     | 1842      | 2042      |
| SERVICE WEIGHT                              |    | kg | 52-54         | 57-59         | 59-61         | 60-62         | 63-65         | 65-67         | 90       | 112      | 127       | 134       |
| AXLE LOAD LADEN, FRONT/REAR                 |    | kg | 356/2196-2198 | 580/1017-1435 | 688/1871-1873 | 716/1844-1846 | 739/1824-1826 | 821/1744-1746 | 880/1710 | 929/1717 | 1002/1625 | 1037/1597 |
| AXLE LOAD UNLADEN, FRONT/REAR               |    | kg | 37/15-17      | 40/17-19      | 40/19-21      | 39/21-23      | 43/20-22      | 44/21-23      | 59/31    | 66/46    | 76/51     | 80/54     |
| TURNING RADIUS                              | Wa | mm | 817           | 1017          | 1167          | 1217          | 1367          | 1437          | 1567     | 1717     | 2017      | 2217      |

# Mr. Hydro

Mr. Hydro series, which is available in a several number of versions, is the ideal tool to handle loads in humid and damp conditions.

In particular the stainless steel model is suitable for environments where high hygienic standards are enforced, such as the chemical, pharmaceutical or food & beverage industry.

## GS/G

The galvanised pallet truck offers good resistance to corrosion thanks to the hot dip galvanizing process of the frame, the control linkages of the pump body and the handle.

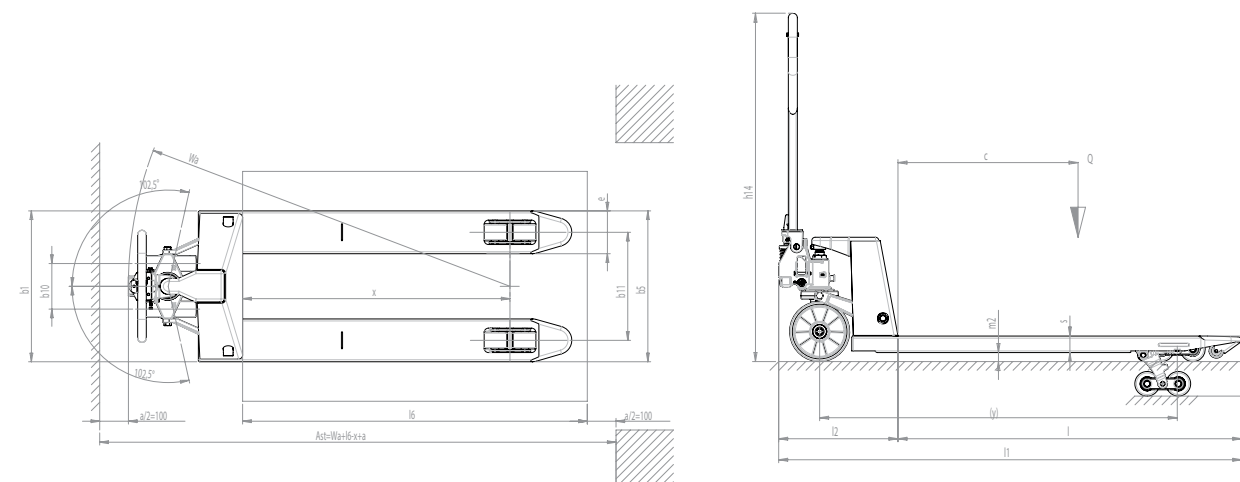
## GS/X

In this version the parts getting in contact with the load and the operator are of aisi 304 electropolished stainless steel, while the remaining parts are subject to a hot dip galvanising treatment.

## GS/I

Inox aisi 304 electropolished stainless steel is used for all metal sheet parts, while the pump is made of brass.

## GS/Galvanised, Stainless steel and Galvinox



| DESCRIPTION                     |   | GS/G 25 S2-S4        | GS/X 25 S2-S4 | GS/I 25 S2-S4 | GS/L G 25 S2-S4 | GS/M G 25 S2-S4 |
|---------------------------------|---|----------------------|---------------|---------------|-----------------|-----------------|
| 1.2                             | MODEL                                       | GS/G 25 S2-S4        | GS/X 25 S2-S4 | GS/I 25 S2-S4 | GS/L G 25 S2-S4 | GS/M G 25 S2-S4 |
| 1.3                             | DRIVE                                       | MANUAL               | MANUAL        | MANUAL        | MANUAL          | MANUAL          |
| 1.4                             | OPERATOR TYPE                               | PEDESTRIAN           | PEDESTRIAN    | PEDESTRIAN    | PEDESTRIAN      | PEDESTRIAN      |
| 1.5                             | LOAD CAPACITY                               | Q kg 2500            | 2500          | 2500          | 2500            | 2500            |
| 1.6                             | LOAD CENTRE DISTANCE                        | c mm 600             | 600           | 600           | 600             | 400             |
| 1.8                             | LOAD DISTANCE, CENTRE OF DRIVE AXLE TO FORK | x mm 932             | 932           | 932           | 932             | 582             |
| 1.9                             | WHEEL BASE                                  | y mm 1192            | 1192          | 1192          | 1192            | 842             |
| <b>WEIGHTS</b>                  |   |                      |               |               |                 |                 |
| 2.1                             | SERVICE WEIGHT                              | kg 61-63             | 62-64         | 67-69         | 66-68           | 52-54           |
| 2.2                             | AXLE LOAD LADEN, FRONT/REAR                 | kg 738/1823-1823     | 739/1823-1825 | 742/1825-1827 | 771/1795-1797   | 575/1977-1979   |
| 2.3                             | AXLE LOAD UNLADEN, FRONT/REAR               | kg 42/19-21          | 43/19-21      | 46/21-23      | 46/20-22        | 35/17-19        |
| <b>TYRES/CHASSIS</b>            |   |                      |               |               |                 |                 |
| 3.1                             | TYRES                                       | N/N                  | NE/NE         | NE/NE         | N/N             | N/N             |
| 3.2                             | TYRE SIZE, FRONT (Ø x width)                | 200x50               | 200x50        | 200x50        | 200x50          | 200x50          |
| 3.3                             | TYRE SIZE, REAR (Ø x width)                 | 82x82-60             | 82x82-60      | 82x82-60      | 82x82-60        | 82x82-60        |
| 3.4                             | SIDE WHEELS (Ø x width)                     | -                    | -             | -             | -               | -               |
| 3.5                             | WHEELS, NUMBER (x=DRIVEN) FRONT/REAR        | 2/2-2/4              | 2/2-2/4       | 2/2-2/4       | 2/2-2/4         | 2/2-2/4         |
| 3.6                             | TREAD, FRONT                                | b10 mm 155           | 155           | 155           | 155             | 155             |
| 3.7                             | TREAD, REAR                                 | b11 mm 375           | 375           | 375           | 535             | 250             |
| <b>DIMENSIONS</b>               |   |                      |               |               |                 |                 |
| 4.4                             | LIFT  | h3 mm 115            | 115           | 115           | 115             | 115             |
| 4.9                             | HEIGHT OF TILLER IN DRIVE POSITION MIN/MAX  | h14 mm 690/1160      | 690/1160      | 690/1160      | 690/1160        | 690/1160        |
| 4.15                            | HEIGHT, LOWERED                             | h13 mm 85            | 85            | 85            | 85              | 85              |
| 4.19                            | OVERALL LENGTH                              | l1 mm 1550           | 1550          | 1550          | 1550            | 1200            |
| 4.20                            | LENGTH TO FACE OF FORKS                     | l2 mm 400            | 400           | 400           | 400             | 400             |
| 4.21                            | OVERALL WIDTH                               | b1 mm 525            | 525           | 525           | 685             | 400             |
| 4.22                            | FORK DIMENSIONS                             | s/e/l mm 55/150/1150 | 55/150/1150   | 55/150/1150   | 55/150/1150     | 55/150/800      |
| 4.25                            | DISTANCE BETWEEN FORK ARMS                  | b5 mm 525            | 525           | 525           | 685             | 400             |
| 4.32                            | GROUND CLEARANCE, CENTRE OF WHEEL BASE      | m2 mm 30             | 30            | 30            | 30              | 30              |
| 4.35                            | TURNING RADIUS                              | Wa mm 1367           | 1367          | 1367          | 1367            | 1017            |
| <b>PERFORMANCE DATA</b>         |   |                      |               |               |                 |                 |
| 5.2                             | LIFT SPEED, LADEN/UNLADEN                   | strokes 13/13        | 13/13         | 13/13         | 13/13           | 13/13           |
| <b>COMPONENT SPECIFICATIONS</b> |   |                      |               |               |                 |                 |
| HYDRAULIC UNIT                  |   | GALVANIZED           | GALVANIZED    | BRASS         | GALVANIZED      | GALVANIZED      |
| FRAME                           |   | GALVANIZED           | INOX          | INOX          | GALVANIZED      | GALVANIZED      |
| PUSH RODS                       |   | GALVANIZED           | GALVANIZED    | INOX          | GALVANIZED      | GALVANIZED      |
| ROCKER ARM                      |   | GALVANIZED           | GALVANIZED    | INOX          | GALVANIZED      | GALVANIZED      |
| WHEELS                          |   | NYLON                | NYLON EXTRA   | NYLON EXTRA   | NYLON           | NYLON           |
| LOAD ROLLERS                    |   | NYLON                | NYLON EXTRA   | NYLON EXTRA   | NYLON           | NYLON           |
| TILLER                          |   | GALVANIZED           | INOX          | INOX          | GALVANIZED      | GALVANIZED      |

G = Rubber, N = Nylon, P = Polyurethane, A = Steel, NE = Nylon extra

|   |     |    |               |               |               |
|---|-----|----|---------------|---------------|---------------|
| FORK LENGTH                                   | l   | mm | 800           | 1150          | 1220          |
| LOAD CENTRE DISTANCE                          | c   | mm | 400           | 600           | 610           |
| WHEELS, NUMBER (x=DRIVEN) FRONT/REAR          |     |    | 2/2-2/4       | 2/2-4/2       | 2/2-2/4       |
| OVERALL LENGTH                                | l1  | mm | 1200          | 1550          | 1620          |
| LOAD DISTANCE, CENTRE OF DRIVE AXLE TO FORK   | x   | mm | 582           | 932           | 1002          |
| WHEEL BASE                                    | y   | mm | 842           | 1192          | 1262          |
| SERVICE WEIGHT                                | kg  |    | 55-57         | 61-63         | 63-65         |
| AXLE LOAD LADEN, FRONT/REAR                   | kg  |    | 579/1976-1978 | 738/1823-1825 | 820/1743-1745 |
| AXLE LOAD UNLADEN, FRONT/REAR                 | kg  |    | 39/16-18      | 42/19-21      | 43/20-22      |
| TURNING RADIUS                                | Wa  | mm | 1017          | 1367          | 1437          |
| AISL WIDTH FOR PALLETES 800x1200-I LENGTHWISE | Ast | mm | 1435          | 1835          | 1855          |



### Hydraulic Pump Made of Brass

In the stainless steel version the hydraulic pump is made of brass to offer maximum resistance to humidity and oxidation.



### Electropolishing

The use of Inox AISI 304, combined with an electropolishing surface treatment, provides the machine with better appearance. Resistance to corrosion also guarantees maximum hygiene.



**PROLIFT** **GS/P25** PX20  
HANDLING LTD

The Lifter scale truck series is available in two models, both of which equipped with an intelligent weighing device with many operating options. It is suitable for lifting and carrying heavy loads; it is therefore very precise and functional in all internal weighing operations.



**Display**

The PX20 pallet truck is a simple, economic and robust tool to be used for the weighing of transported loads. Its large-sized LCD display allows for easy reading of weight and the setting of tare simply and immediately.



**GS/P25 - Stainless Steel**

GS/P differs from PX20 due to its hydraulic unit of higher load capacity (2.500 kg) and the bigger number of functions, such as the items counter and the load totalization indicator. The pallet truck may also be equipped with a thermal printer, memory card SD or may be provided in the INOX version.



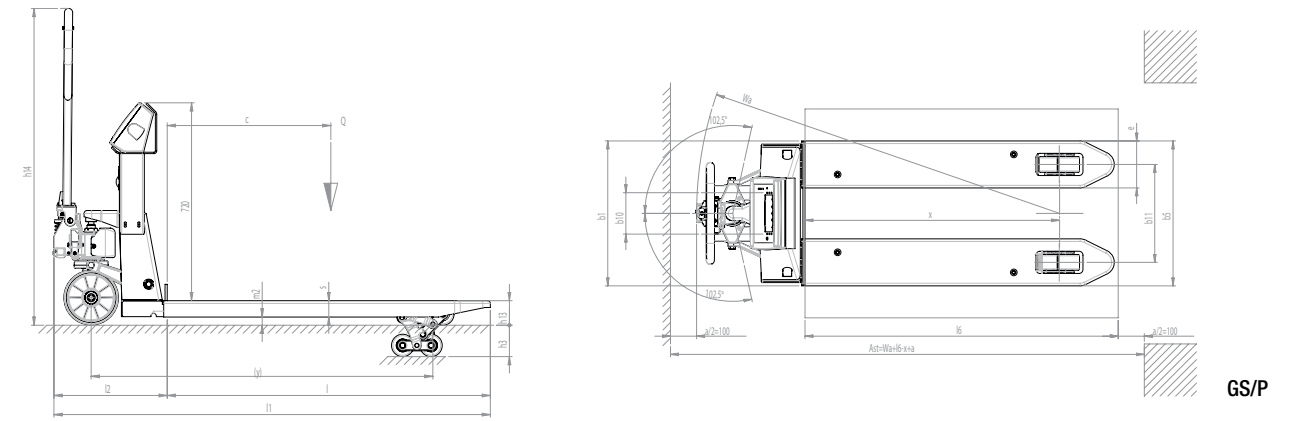
**Frame Structure**

The structure is made up of a double frame and a lower fork on which a counter fork is placed; both forks house four load cells that allow for a uniform load distribution, thus keeping weighing precision even in case of collision and unbalanced load.

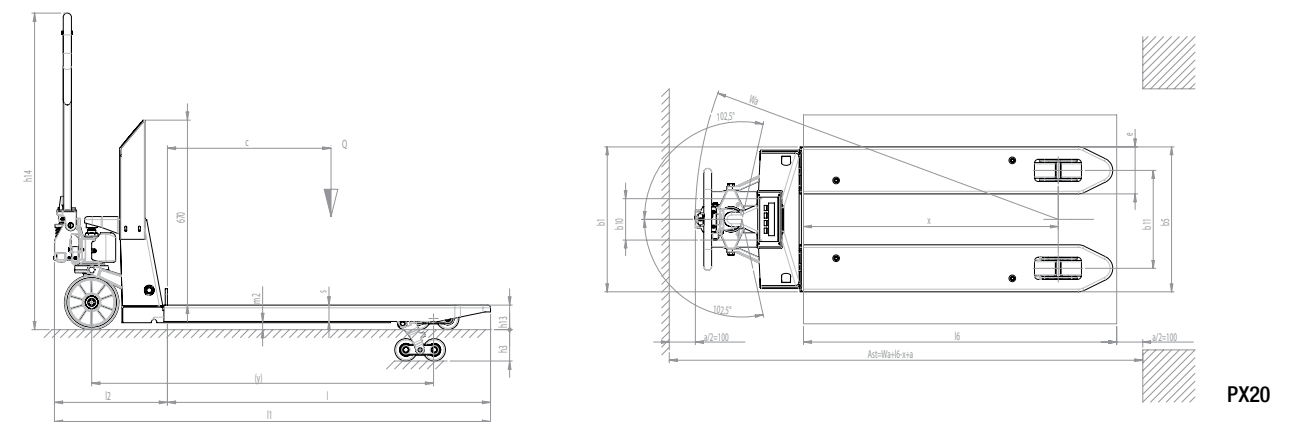


**Memory Card SD**

GS/P pallet truck is available with printing on SD memory card and approved weighing.



GS/P



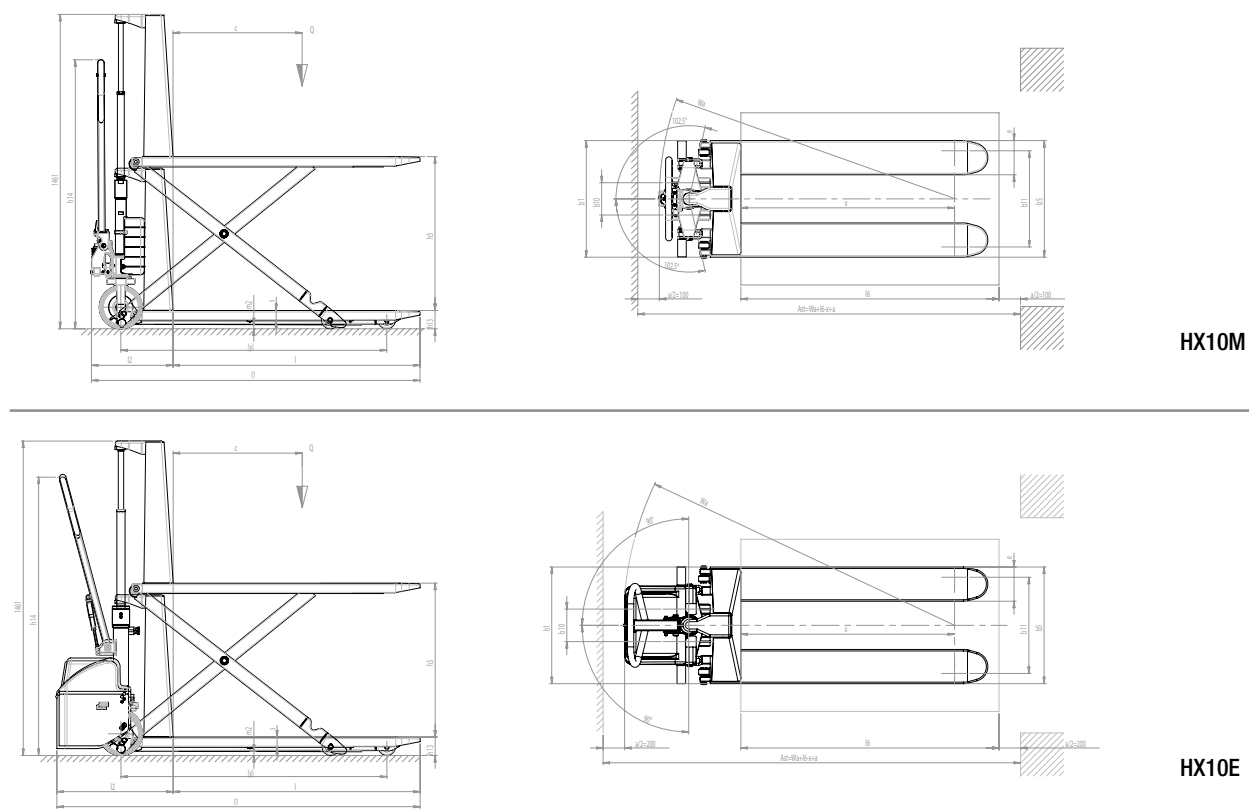
PX20

| DESCRIPTION                                      |              | GS/P  | GS/P CE-M HOMOLOGATION                        | GS/P INOX                                     | PX20                          |
|--|--------------|---|---|---|-------------------------------|
| 1.2 MODEL  |              | GS/P  | GS/P CE-M HOMOLOGATION                        | GS/P INOX                                     | PX20                          |
| 1.3 DRIVE  |              | MANUAL  | MANUAL  | MANUAL  | MANUAL                        |
| 1.4 OPERATOR TYPE                                |              | PEDESTRIAN                                    | PEDESTRIAN                                    | PEDESTRIAN                                    | PEDESTRIAN                    |
| 1.5 LOAD CAPACITY                                | Q kg         | 2500  | 2500  | 2500  | 2000                          |
| 1.6 LOAD CENTRE DISTANCE                         | c mm         | 600   | 600   | 600   | 600                           |
| 1.8 LOAD DISTANCE, CENTRE OF DRIVE AXLE TO FORK  | x mm         | 975,5   | 975,5   | 975,5   | 975                           |
| 1.9 WHEEL BASE                                   | y mm         | 1250  | 1250  | 1250  | 1255                          |
| <b>WEIGHTS</b>                                   |              |   |   |   |                               |
| 2.1 SERVICE WEIGHT                               | kg           | 124   | 124   | 132   | 113                           |
| 2.2 AXLE LOAD LADED, FRONT/REAR                  | kg           | 787/1837                                      | 787/1837                                      | 790/1842                                      | 633/1480                      |
| 2.3 AXLE LOAD UNLADEN, FRONT/REAR                | kg           | 77/47   | 77/47   | 82/50   | 71/42                         |
| <b>TYRES/CHASSIS</b>                             |              |   |   |   |                               |
| 3.1 TYRES  |              | P/P   | P/P   | NE/NE   | P/P                           |
| 3.2 TYRE SIZE, FRONT (Ø x width)                 |              | 200x55  | 200x55  | 200x50  | 200x55                        |
| 3.3 TYRE SIZE, REAR (Ø x width)                  |              | 82x60   | 82x60   | 82x60   | 82x60                         |
| 3.4 SIDE WHEELS (Ø x width)                      |              | -   | -   | -   | -                             |
| 3.5 WHEELS, NUMBER (x=DRIVEN) FRONT/REAR         |              | 2/4   | 2/4   | 2/4   | 2/4                           |
| 3.6 TREAD, FRONT                                 | b10 mm       | 155   | 155   | 155   | 155                           |
| 3.7 TREAD, REAR                                  | b11 mm       | 375   | 375   | 375   | 375                           |
| <b>DIMENSIONS</b>                                |              |   |   |   |                               |
| 4.4 LIFT   | h3 mm        | 115   | 115   | 115   | 115                           |
| 4.9 HEIGHT OF TILLER IN DRIVE POSITION MIN/MAX   | h14 mm       | 690/1160                                      | 690/1160                                      | 690/1160                                      | 690/1160                      |
| 4.15 HEIGHT, LOWERED                             | h13 mm       | 90  | 90  | 90  | 90                            |
| 4.19 OVERALL LENGTH                              | l1 mm        | 1596  | 1596  | 1596  | 1596                          |
| 4.20 LENGTH TO FACE OF FORKS                     | l2 mm        | 411   | 411   | 411   | 411                           |
| 4.21 OVERALL WIDTH                               | b1 mm        | 555   | 555   | 555   | 555                           |
| 4.22 FORK DIMENSIONS                             | s/e/l mm     | 60/180/1185                                   | 60/180/1185                                   | 60/180/1185                                   | 60/180/1185                   |
| 4.25 DISTANCE BETWEEN FORK ARMS                  | b5 mm        | 555   | 555   | 555   | 555                           |
| 4.32 GROUND CLEARANCE, CENTRE OF WHEEL BASE      | m2 mm        | 30  | 30  | 30  | 30                            |
| 4.34 AISLE WIDTH FOR PALLETS 800x1200 LENGHTWISE | Ast mm       | 1851  | 1851  | 1851  | 1815                          |
| 4.35 TURNING RADIUS                              | Wa mm        | 1426  | 1426  | 1426  | 1390                          |
| <b>PERFORMANCE DATA</b>                          |              |   |   |   |                               |
| 5.2 LIFT SPEED, LADEN/UNLADEN                    | strokes      | 13/13   | 13/13   | 13/13   | 13/13                         |
| <b>SCALE</b>                                     |              |   |   |   |                               |
| 6.4 BATTERY VOLTAGE, NOMINAL CAPACITY            | V/Ah         | 6/4   | 6/4   | 6/4   | 6/1,1                         |
| DISPLAY  |              | Liquid crystals/6 digits 25mm                 | Liquid crystals/6 digits 25mm                 | Liquid crystals/6 digits 25mm                 | Liquid crystals/6 digits 25mm |
| UNITS OF MEASUREMENT                             |              | kg/lb   | kg/lb   | kg/lb   | kg/lb                         |
| FUNCTIONS  |              | Tare/Auto-off/Weight totalizer/Piece counting | Tare/Auto-off/Weight totalizer/Piece counting | Tare/Auto-off/Weight totalizer/Piece counting | Tare/Unbalanced load/Auto-off |
| AUTONOMY   | h            | 50  | 50  | 50  | 30                            |
| PRECISION  | % full scale | 0,05  | 0,05  | 0,05  | 0,05                          |
| LOAD CELLS                                       | n.           | 4   | 4   | 4   | 4                             |
| DIVISION   | kg           | 0,5   | 1   | 0,5   | 0,5                           |

**PROLIFT** **HX** HX10M - HX10E  
HANDLING LTD

The HX10 series, available in manual and electric version, makes possible an easy and light lifting to a height of 800 mm, thus becoming a practical work platform, which is suitable for places such as machine workshops.

This pallet truck is also able to carry out the support function and material supply along the assembly and production lines.



| DESCRIPTION                                      |          | HX10M 1150x540 | HX10M 1150x680 | HX10E 1150x540     | HX10E 1150x680     | HX10E 1500x540     | HX10E 1800x540     | HX10E 2000x540     |
|--|----------|----------------|----------------|--------------------|--------------------|--------------------|--------------------|--------------------|
| 1.2 MODEL  |          | MANUAL         | MANUAL         | MANUAL             | MANUAL             | MANUAL             | MANUAL             | MANUAL             |
| 1.3 DRIVE  |          | PEDESTRIAN     | PEDESTRIAN     | PEDESTRIAN         | PEDESTRIAN         | PEDESTRIAN         | PEDESTRIAN         | PEDESTRIAN         |
| 1.4 OPERATOR TYPE                                |          |                |                |                    |                    |                    |                    |                    |
| 1.5 LOAD CAPACITY                                | Q kg     | 1000           | 1000           | 1000               | 1000               | 1000               | 1000               | 1000               |
| 1.6 LOAD CENTRE DISTANCE                         | c mm     | 600            | 600            | 600                | 600                | 762                | 900                | 1000               |
| 1.8 LOAD DISTANCE, CENTRE OF DRIVE AXLE TO FORK  | x mm     | 993            | 993            | 993                | 993                | 1368               | 1643               | 1843               |
| 1.9 WHEEL BASE                                   | y mm     | 1236           | 1236           | 1236               | 1236               | 1611               | 1886               | 2086               |
| <b>WEIGHTS</b>                                   |          |                |                |                    |                    |                    |                    |                    |
| 2.1 SERVICE WEIGHT                               | kg       | 104            | 111            | 139 (144*)         | 146                | 235 (240*)         | 259 (264*)         | 262 (267*)         |
| 2.2 AXLE LOAD LADEN, FRONT/REAR                  | kg       | 339/765        | 344/767        | 429/710 (434/710*) | 434/712 (439/712*) | 531/704 (536/704*) | 572/687 (577/687*) | 584/678 (589/678*) |
| 2.3 AXLE LOAD UNLADEN, FRONT/REAR                | kg       | 79/25          | 84/27          | 111/28 (116/28*)   | 116/30             | 155/80 (160/80*)   | 178/81 (183/81*)   | 180/82 (185/82*)   |
| <b>TYRES/CHASSIS</b>                             |          |                |                |                    |                    |                    |                    |                    |
| 3.1 TYRES  | P/P      | P/P            | G/P            | G/P                | G/P                | G/P                | G/P                | G/P                |
| 3.2 TYRE SIZE, FRONT (Ø x width)                 |          | 200x45         | 200x45         | 200x50             | 200x50             | 200x50             | 200x50             | 200x50             |
| 3.3 TYRE SIZE, REAR (Ø x width)                  |          | 80x50          | 80x50          | 80x50              | 80x50              | 80x50              | 80x50              | 80x50              |
| 3.4 SIDE WHEELS (Ø x width)                      |          | -              | -              | -                  | -                  | -                  | -                  | -                  |
| 3.5 WHEELS, NUMBER (x=DRIVEN) FRONT/REAR         |          | 2/2            | 2/2            | 2/2                | 2/2                | 2/2                | 2/2                | 2/2                |
| 3.6 TREAD, FRONT                                 | b10 mm   | 150            | 150            | 150                | 150                | 150                | 150                | 150                |
| 3.7 TREAD, REAR                                  | b11 mm   | 447            | 587            | 447                | 587                | 447                | 447                | 447                |
| <b>DIMENSIONS</b>                                |          |                |                |                    |                    |                    |                    |                    |
| 4.4 LIFT   | h3 mm    | 715            | 715            | 715                | 715                | 715                | 715                | 715                |
| 4.9 HEIGHT OF TILLER IN DRIVE POSITION MIN/MAX   | h14 mm   | 415/1250       | 415/1250       | 915/1300           | 915/1300           | 915/1300           | 915/1300           | 915/1300           |
| 4.15 HEIGHT, LOWERED                             | h13 mm   | 85             | 85             | 85                 | 85                 | 85                 | 85                 | 85                 |
| 4.19 OVERALL LENGTH                              | l1 mm    | 1526           | 1526           | 1690               | 1690               | 2065               | 2340               | 2540               |
| 4.20 LENGTH TO FACE OF FORKS                     | l2 mm    | 376            | 376            | 540                | 540                | 540                | 540                | 540                |
| 4.21 OVERALL WIDTH                               | b1 mm    | 540            | 680            | 540                | 680                | 540                | 540                | 540                |
| 4.22 FORK DIMENSIONS                             | s/e/l mm | 48/160/1150    | 48/160/1150    | 48/160/1150        | 48/160/1150        | 48/160/1525        | 48/160/1800        | 48/160/2000        |
| 4.25 DISTANCE BETWEEN FORK ARMS                  | b5 mm    | 540            | 680            | 540                | 680                | 540                | 540                | 540                |
| 4.32 GROUND CLEARANCE, CENTRE OF WHEEL BASE      | m2 mm    | 21             | 21             | 21                 | 21                 | 21                 | 21                 | 21                 |
| 4.34 AISLE WIDTH FOR PALLETS 800x1200 LENGTHWISE | Ast mm   | 1779           | 1779           | 1948               | 1948               | 2273               | 2548               | 2748               |
| 4.35 TURNING RADIUS                              | Wa mm    | 1372           | 1372           | 1541               | 1541               | 1916               | 2191               | 2391               |
| <b>PERFORMANCE DATA</b>                          |          |                |                |                    |                    |                    |                    |                    |
| 5.2 LIFT SPEED, LADEN/UNLADEN                    | strokes  | 62/30          | 62/30          | 0,08/0,13          | 0,08/0,13          | 0,08/0,13          | 0,08/0,13          | 0,08/0,13          |
| 5.3 LOWERING SPEED, LADEN/UNLADEN                | m/s      | 0              | 0              | 0,13/0,06          | 0,13/0,06          | 0,13/0,06          | 0,13/0,06          | 0,13/0,06          |
| <b>ELECTRIC MOTORS</b>                           |          |                |                |                    |                    |                    |                    |                    |
| 6.2 LIFT MOTOR POWER                             | kW       |                |                | 1,6                | 1,6                | 1,6                | 1,6                | 1,6                |
| 6.4 BATTERY VOLTAGE, NOMINAL CAPACITY C5         | V/Ah     |                |                | 12/60              | 12/60              | 12/60              | 12/60              | 12/60              |
| 6.5 BATTERY WEIGHT                               | kg       |                |                | 14                 | 14                 | 14                 | 14                 | 14                 |
| 8.4 SOUND LEVEL AT DRIVER'S EAR                  | dB(A)    |                |                | 67                 | 67                 | 67                 | 67                 | 67                 |

\*G=Rubber, N=Nylon, P=Polyurethane, A=Steel, NE=Nylon extra \* On board battery charger version

| MODEL                                       |        | HX10E 1150x540 GEL/PLUS | HX10E 1500x540 GEL/PLUS | HX10E 1800x540 GEL/PLUS | HX10E 2000x540 GEL/PLUS |
|---|--------|-------------------------|-------------------------|-------------------------|-------------------------|
| SERVICE WEIGHT                              | kg     | 145                     | 241                     | 265                     | 268                     |
| AXLE LOAD LADEN, FRONT/REAR                 | kg     | 435/710                 | 537/704                 | 578/687                 | 590/678                 |
| AXLE LOAD UNLADEN, FRONT/REAR               | kg     | 116/28                  | 161/80                  | 184/81                  | 186/82                  |
| OVERALL LENGTH                              | l1 mm  | 1720                    | 2095                    | 2370                    | 2570                    |
| LENGTH TO FACE OF FORKS                     | l2 mm  | 570                     | 570                     | 570                     | 570                     |
| AISLE WIDTH FOR PALLETS 800x1200 LENGTHWISE | Ast mm | 1978                    | 2303                    | 2578                    | 2778                    |
| TURNING RADIUS                              | Wa mm  | 1571                    | 1946                    | 2221                    | 2421                    |
| BATTERY VOLTAGE, NOMINAL CAPACITY C5        | V/Ah   | 12/50                   | 12/50                   | 12/50                   | 12/50                   |
| BATTERY WEIGHT                              | kg     | 19                      | 19                      | 19                      | 19                      |

Battery and external battery charger. Also available in GEL version and with an integrated battery charger.



**Front and Rear Stabilizers**

The new control linkage makes the entry onto the closed side of the pallet possible by slight lifting, facilitating successive handling phases. Furthermore, a certain machine stability has been obtained using load rollers in a more advanced position and providing front stabilizers as standard equipment. Rear stabilizers, in turn, render work stable and safe even in the case of elevated loads once the 400 mm of lifting up have been exceeded.



**Auto Levelling System**

- Automatic system whose photocell adjusts the height of the forks, maintaining the work height set.
- An optical and acoustic signal is activated at every fork movement.
- Possibility of adjusting the photocell both in height and reading angle.
- Micro-limit switch, active both on the way up to prevent superfluous absorption of energy and on the way down to protect the operator.



**Control Lever**

The hydraulic unit has been recently redesigned to allow for less effort at the steering wheel for all loads and a quick elevated function (30 cycles) for loads up to 150 kg.



**Emergency Pushbutton**

The emergency pushbutton with a battery cut-off (isolator) switch function allows for a safer work.



**PROLIFT** **CX 12 - 14**  
HANDLING LTD

The CX electric pallet trucks are available in different versions. They are suitable for carrying loads on smooth or paved surfaces. Its small size and turning radius make it the ideal tool to work with in confined spaces, such as lorries or narrow aisles.



Integrated battery and battery charger

**Steering Wheel and Controls**



- Ergonomic tiller
- Luminous indicator for battery state control.
- Butterfly valves for traction control.
- Safety pushbutton with warning buzzer.
- Forks way up/down control positioned on both sides of the handle (only on CX14).
- Hour counter in the Plus and Gel versions (only on CX14).
- "Tortoise" pushbutton for slow motion, which allows for the carrying out of operations with the tiller in vertical position.

**Plus Batteries**



The Plus versions are equipped with semitractor batteries that guarantee greater autonomy and an operative life that allows for up to 5 times higher a number of charge life cycles. Thanks to the design of its guard, access to batteries is easy and rapid; this model also optimally combines size, power and low running cost also due to the integrated batteries and battery charger.

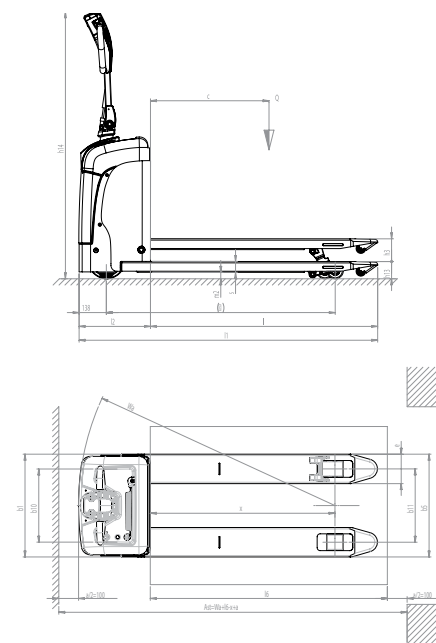
**Compact Dimensions**

Thanks to the B1 width, which is equal to the fork gauge, and the L2 measurement of 360 mm, the CX12 electronic pallet truck is the ideal tool for the handling of pallets on lorries, in supermarket aisles and any application where space is limited. This machine is the best configuration in its category thanks to the frame width, in-service weight and turning radius, guaranteeing great maneuverability and compactness.

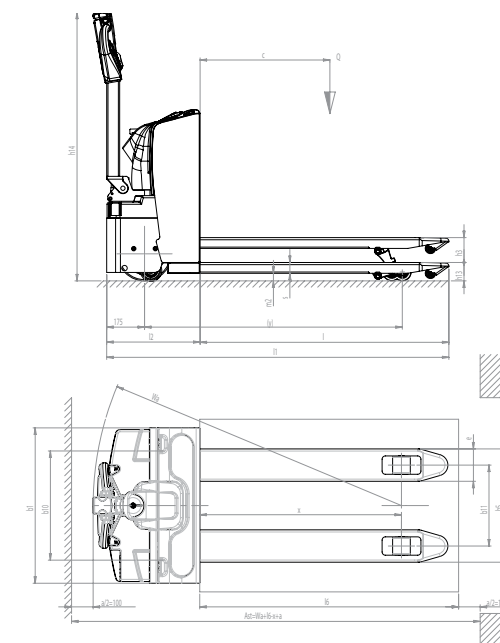


**Stabilizers**

Two stabilizing wheels enable movement even on more difficult surfaces thus guaranteeing maximum stability in any condition of use.



CX12



CX14

| DESCRIPTION             |   | CX12 S2-S4 | CX12 PLUS S2-S4 | CX12 GEL S2-S4 | CX14 S2-S4    | CX14 PLUS S2-S4 | CX14 GEL S2-S4 |
|-------------------------|---|------------|-----------------|----------------|---------------|-----------------|----------------|
| 1.2                     | MODEL                                       |            |                 |                |               |                 |                |
| 1.3                     | DRIVE                                       | ELECTRIC   | ELECTRIC        | ELECTRIC       | ELECTRIC      | ELECTRIC        | ELECTRIC       |
| 1.4                     | OPERATOR TYPE                               | PEDESTRIAN | PEDESTRIAN      | PEDESTRIAN     | PEDESTRIAN    | PEDESTRIAN      | PEDESTRIAN     |
| 1.5                     | LOAD CAPACITY                               | Q kg       | 1200            | 1200           | 1400          | 1400            | 1400           |
| 1.6                     | LOAD CENTRE DISTANCE                        | c mm       | 600             | 600            | 600           | 600             | 600            |
| 1.8                     | LOAD DISTANCE, CENTRE OF DRIVE AXLE TO FORK | x mm       | 886             | 886            | 886           | 935             | 935            |
| 1.9                     | WHEEL BASE                                  | y mm       | 1119            | 1119           | 1119          | 1192            | 1192           |
| <b>WEIGHTS</b>          |   |            |                 |                |               |                 |                |
| 2.1                     | SERVICE WEIGHT WITH BATTERY (see line 6,5)  | kg         | 155-157         | 165-167        | 160-162       | 201-207         | 246-250        |
| 2.2                     | AXLE LOAD LADEN, FRONT/REAR                 | kg         | 431/924-926     | 441/924-926    | 436/924-926   | 562/1041-1045   | 599/1047-1051  |
| 2.3                     | AXLE LOAD UNLADEN, FRONT/REAR               | kg         | 124/31-33       | 134/31-33      | 129/31-33     | 170/33-37       | 207/39-43      |
| <b>TYRES/CHASSIS</b>    |   |            |                 |                |               |                 |                |
| 3.1                     | TYRES                                       | G+P/P      | G+P/P           | G+P/P          | G+P/P         | G+P/P           | G+P/P          |
| 3.2                     | TYRE SIZE, FRONT (Ø x width)                | 186x50     | 186x50          | 186x50         | 250x76        | 250x76          | 250x76         |
| 3.3                     | TYRE SIZE, REAR (Ø x width)                 | 82x82-60   | 82x82-60        | 82x82-60       | 82x80-60      | 82x80-60        | 82x80-60       |
| 3.4                     | SIDE WHEELS (Ø x width)                     | 75x25      | 75x25           | 75x25          | 100x40        | 100x40          | 100x40         |
| 3.5                     | WHEELS, NUMBER (x=DRIVEN) FRONT/REAR        | 1x+2/2-2/4 | 1x+2/2-2/4      | 1x+2/2-2/4     | 1x+2/2-2/4    | 1x+2/2-2/4      | 1x+2/2-2/4     |
| 3.6                     | TREAD, FRONT                                | b10 mm     | 369             | 369            | 369           | 506             | 506            |
| 3.7                     | TREAD, REAR                                 | b11 mm     | 371             | 371            | 371           | 375             | 375            |
| <b>DIMENSIONS</b>       |   |            |                 |                |               |                 |                |
| 4.4                     | LIFT  | h3 mm      | 115             | 115            | 115           | 115             | 115            |
| 4.9                     | HEIGHT OF TILLER IN DRIVE POSITION MIN/MAX  | h14 mm     | 885/1345        | 885/1345       | 885/1345      | 786/1242        | 786/1242       |
| 4.15                    | HEIGHT, LOWERED                             | h13 mm     | 85              | 85             | 85            | 85              | 85             |
| 4.19                    | OVERALL LENGTH                              | l1 mm      | 1510            | 1510           | 1510          | 1650            | 1650           |
| 4.20                    | LENGTH TO FACE OF FORKS                     | l2 mm      | 360             | 360            | 360           | 500             | 500            |
| 4.21                    | OVERALL WIDTH                               | b1 mm      | 520             | 520            | 520           | 720             | 720            |
| 4.22                    | FORK DIMENSIONS                             | s/e/l mm   | 55/150/1150     | 55/150/1150    | 55/150/1150   | 50/150/1150     | 50/150/1150    |
| 4.25                    | DISTANCE BETWEEN FORK ARMS                  | b5 mm      | 520             | 520            | 520           | 525             | 525            |
| 4.32                    | GROUND CLEARANCE, CENTRE OF WHEEL BASE      | m2 mm      | 30              | 30             | 30            | 35              | 35             |
| 4.34                    | AXLE WIDTH FOR PALLETS 800x1200 LENGTHWISE  | Ast mm     | 1782            | 1782           | 1782          | 1900            | 1900           |
| 4.35                    | TURNING RADIUS                              | Wa mm      | 1268            | 1268           | 1268          | 1435            | 1435           |
| <b>PERFORMANCE DATA</b> |   |            |                 |                |               |                 |                |
| 5.1                     | TRAVEL SPEED, LADEN/UNLADEN                 | km/h       | 4,3/4,8         | 4,3/4,8        | 4,3/4,8       | 4,5/4,7         | 4,5/4,7        |
| 5.2                     | LIFT SPEED, LADEN/UNLADEN                   | m/s        | 0,03/0,04       | 0,03/0,04      | 0,03/0,04     | 0,02/0,03       | 0,02/0,03      |
| 5.3                     | LOWERING SPEED, LADEN/UNLADEN               | m/s        | 0,05/0,02       | 0,05/0,02      | 0,05/0,02     | 0,04            | 0,04           |
| 5.8                     | MAX GRADEABILITY, LADEN/UNLADEN             |            | 10/25           | 10/25          | 10/25         | 5/10            | 5/10           |
| 5.10                    | SERVICE BRAKE                               |            | ELECTRIC        | ELECTRIC       | ELECTRIC      | ELECTRIC        | ELECTRIC       |
| <b>ELECTRIC MOTORS</b>  |   |            |                 |                |               |                 |                |
| 6.1                     | DRIVE MOTOR POWER                           | kW         | 0,35            | 0,35           | 0,35          | 0,7             | 0,7            |
| 6.2                     | LIFT MOTOR POWER                            | kW         | 0,4             | 0,4            | 0,4           | 0,4             | 0,4            |
| 6.4                     | BATTERY VOLTAGE, NOMINAL CAPACITY C20       | V/Ah       | 24/60           | 24/60 (45 C5)  | 24/48 (40 C5) | 24/70 (C20)     | 24/118         |
| 6.5                     | BATTERY WEIGHT                              | V/Ah       | 2x14            | 2x19           | 2x16          | 32              | 78             |
| 8.4                     | SOUND LEVEL AT DRIVER'S EAR                 | dB(A)      | 67              | 67             | 67            | 76              | 76             |

G = Rubber, N = Nylon, P = Polyurethane, A = Steel, NE = Nylon extra

| MODEL                                       |        | CX12 S2-S4    | CX12 PLUS S2-S4 | CX14 S2-S4    |
|---|--------|---------------|-----------------|---------------|
| FORK LENGTH                                 | l mm   | 800           | 1000            | 1000          |
| LOAD CENTRE DISTANCE                        | c mm   | 400           | 500             | 500           |
| WHEELS, NUMBER (x=DRIVEN) FRONT/REAR        |        | 1x+2/2-2/4    | 1x+2/2-2/4      | 1x+2/2-2/4    |
| OVERALL LENGTH                              | l1 mm  | 1160          | 1360            | 1500          |
| WHEEL BASE                                  | y mm   | 769           | 969             | 1042          |
| LOAD DISTANCE, CENTRE OF DRIVE AXLE TO FORK | x mm   | 536           | 736             | 785           |
| SERVICE WEIGHT WITH BATTERY (see line 6,5)  | kg     | 150-152       | 153-155         | 199-203       |
| AXLE LOAD LADEN, FRONT/REAR                 | kg     | 333/1017-1019 | 415/938-940     | 561/1038-1042 |
| AXLE LOAD UNLADEN, FRONT/REAR               | kg     | 121/29-31     | 123/30-32       | 169/30-34     |
| TURNING RADIUS                              | Wa mm  | 918           | 1118            | 1285          |
| AXLE WIDTH FOR PALLETS 800x1200 LENGTHWISE  | Ast mm | 1382          | 1582            | 1700          |

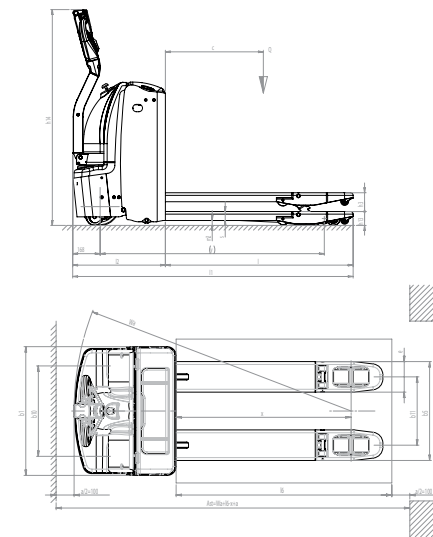


**PROLIFT** **QX 18 - 20 - 20DL**  
HANDLING LTD

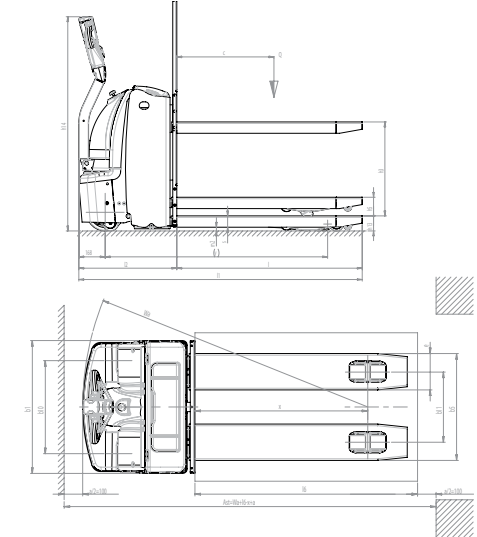
The QX pallet truck series meets the needs of a vast number of applications guaranteeing high performance, even during the haviest operations. The ac technology introduced in the traction motor promotes high energy efficiency and a longer battery charging duration; the absence of brushes in the motor and the simpler structure of the motor increase system reliability. Furthermore, the double lifting version keeps the high functionality of the electrical pallet truck and combines it with the practical convenience of stackers.

**QX/DL**

In this version the QX20 structure still has a load capacity of 2.000 Kg but has been extended with the addition of a central cylinder that allows for the lifting of an 800 kg load on the plated forks in order to create a smooth support platform for the operator. The load backrest also guarantees total safety. The plated forks and clamps can be lifted independently through the pushbuttons on the wheelhouse.



QX18-20



QX20DL

| DESCRIPTION             |   | QX18 S2-S4 | QX20 S2-S4    | QX20 DL S4  |
|-------------------------|---|------------|---------------|-------------|
| 1.2                     | MODEL                                       | QX18 S2-S4 | QX20 S2-S4    | QX20 DL S4  |
| 1.3                     | DRIVE                                       | ELECTRIC   | ELECTRIC      | ELECTRIC    |
| 1.4                     | OPERATOR TYPE                               | PEDESTRIAN | PEDESTRIAN    | PEDESTRIAN  |
| 1.5                     | LOAD CAPACITY                               | Q kg       | 2000          | 2000/800    |
| 1.6                     | LOAD CENTRE DISTANCE                        | c mm       | 600           | 600         |
| 1.8                     | LOAD DISTANCE, CENTRE OF DRIVE AXLE TO FORK | x mm       | 973           | 896         |
| 1.9                     | WHEEL BASE                                  | y mm       | 1373          | 1373        |
| <b>WEIGHTS</b>          |   |            |               |             |
| 2.1                     | SERVICE WEIGHT WITH BATTERY (see line 6,5)  | kg         | 510-515       | 615         |
| 2.2                     | AXLE LOAD LADEN, FRONT/REAR                 | kg         | 874/1436-1441 | 980-1635    |
| 2.3                     | AXLE LOAD UNLADEN, FRONT/REAR               | kg         | 388/122-127   | 440-175     |
| <b>TYRES/CHASSIS</b>    |   |            |               |             |
| 3.1                     | TYRES                                       |            | P+P/P         | P+P/P       |
| 3.2                     | TYRE SIZE, FRONT (Ø x width)                |            | 230x75        | 230x75      |
| 3.3                     | TYRE SIZE, REAR (Ø x width)                 |            | 85x90-80      | 85x80       |
| 3.4                     | SIDE WHEELS (Ø x width)                     |            | 100x40        | 100x40      |
| 3.5                     | WHEELS, NUMBER (x=DRIVEN) FRONT/REAR        |            | 1x+2/2-2/4    | 1x+2/4      |
| 3.6                     | TREAD, FRONT                                | b10 mm     | 506           | 506         |
| 3.7                     | TREAD, REAR                                 | b11 mm     | 380           | 380         |
| <b>DIMENSIONS</b>       |   |            |               |             |
| 4.4                     | LIFT  | h3 mm      | 115           | 580         |
| 4.6                     | INITIAL LIFT                                | h5 mm      | -             | 115         |
| 4.9                     | HEIGHT OF TILLER IN DRIVE POSITION MIN/MAX  | h14 mm     | 784/1320      | 784/1320    |
| 4.15                    | HEIGHT, LOWERED                             | h13 mm     | 85            | 93          |
| 4.19                    | OVERALL LENGTH                              | l1 mm      | 1715          | 1755        |
| 4.20                    | LENGTH TO FACE OF FORKS                     | l2 mm      | 565           | 605         |
| 4.21                    | OVERALL WIDTH                               | b1 mm      | 716           | 716         |
| 4.22                    | FORK DIMENSIONS                             | s/e/l mm   | 55/170/1150   | 70/196/1150 |
| 4.25                    | DISTANCE BETWEEN FORK ARMS                  | b5 mm      | 550           | 576         |
| 4.32                    | GROUND CLEARANCE, CENTRE OF WHEEL BASE      | m2 mm      | 30            | 23          |
| 4.34                    | AISLE WIDTH FOR PALLETS 800x1200 LENGTHWISE | Ast mm     | 2002          | 2079        |
| 4.35                    | TURNING RADIUS                              | Wa mm      | 1575          | 1575        |
| <b>PERFORMANCE DATA</b> |   |            |               |             |
| 5.1                     | TRAVEL SPEED, LADEN/UNLADEN                 | km/h       | 6,0/6,0       | 6,0/6,0     |
| 5.2                     | LIFT SPEED, LADEN/UNLADEN                   | m/s        | 0,04/0,05     | 0,04/0,05   |
| 5.3                     | LOWERING SPEED, LADEN/UNLADEN               | m/s        | 0,05/0,04     | 0,05/0,04   |
| 5.8                     | MAX GRADEABILITY, LADEN/UNLADEN             |            | 10/20         | 10/20       |
| 5.10                    | SERVICE BRAKE                               |            | ELECTRIC      | ELECTRIC    |
| <b>ELECTRIC MOTORS</b>  |   |            |               |             |
| 6.1                     | DRIVE MOTOR POWER                           | kW         | 1,2           | 1,5         |
| 6.2                     | LIFT MOTOR POWER                            | kW         | 2,2           | 2,2         |
| 6.4                     | BATTERY VOLTAGE, NOMINAL CAPACITY C5        | V/Ah       | 24/180        | 24/200      |
| 6.5                     | BATTERY WEIGHT                              | kg         | 190           | 188         |
| 8.4                     | SOUND LEVEL AT DRIVER'S EAR                 | dB(A)      | 58,4          | 58,4        |

G = Rubber, N = Nylon, P = Polyurethane, A = Steel, NE = Nylon extra

| MODEL                                       |        | QX18 S2-S4    | QX20 S2-S4    |
|---|--------|---------------|---------------|
| FORK LENGTH                                 | l mm   | 1000          | 1000          |
| LOAD CENTRE DISTANCE                        | c mm   | 500           | 500           |
| OVERALL LENGTH                              | l1 mm  | 1565          | 1565          |
| WHEEL BASE                                  | y mm   | 1223          | 1223          |
| LOAD DISTANCE, CENTRE OF DRIVE AXLE TO FORK | x mm   | 823           | 823           |
| SERVICE WEIGHT WITH BATTERY (see line 6,5)  | kg     | 502-507       | 502-507       |
| AXLE LOAD LADEN, FRONT/REAR                 | kg     | 868/1434-1439 | 922/1580-1585 |
| AXLE LOAD UNLADEN, FRONT/REAR               | kg     | 382/120-125   | 382/120-125   |
| TURNING RADIUS                              | Wa mm  | 1425          | 1425          |
| AISLE WIDTH FOR PALLETS 800x1200 LENGTHWISE | Ast mm | 1802          | 1802          |
| <b>BATTERY</b>                              |        |               |               |
| BATTERY VOLTAGE, NOMINAL CAPACITY C5        | V/Ah   | 24/180        | 24/230        |
| BATTERY WEIGHT                              | kg     | 185           | 212           |



**Tiller**

- Ergonomic tiller
- Luminous indicator for battery state control.
- Butterfly valves for traction control.
- Safety pushbutton with warning buzzer.
- Forks way up/down control positioned on both sides of the handle
- Hour counter
- "Tortoise" pushbutton for slow motion, which allows for the carrying out of operations with the tiller in vertical position.
- Ideal for running in confined spaces.



**Motor Wheels and Stabilizing Wheels**

The motor wheel equipped with AC technology guarantees an excellent speed control system, with or without load on board (6 km/h). Two stabilizing wheels also enable movement even on more difficult surfaces, ensuring maximum stability in any condition of use.



**Forks and Connection**

The structure of QX pallet trucks is designed to guarantee maximum solidity and reliability: front forks are made of very thick cast iron just like clevis and other connecting rod parts. Impact on pallets and difficult surfaces is no longer a problem!



**AC Technology**

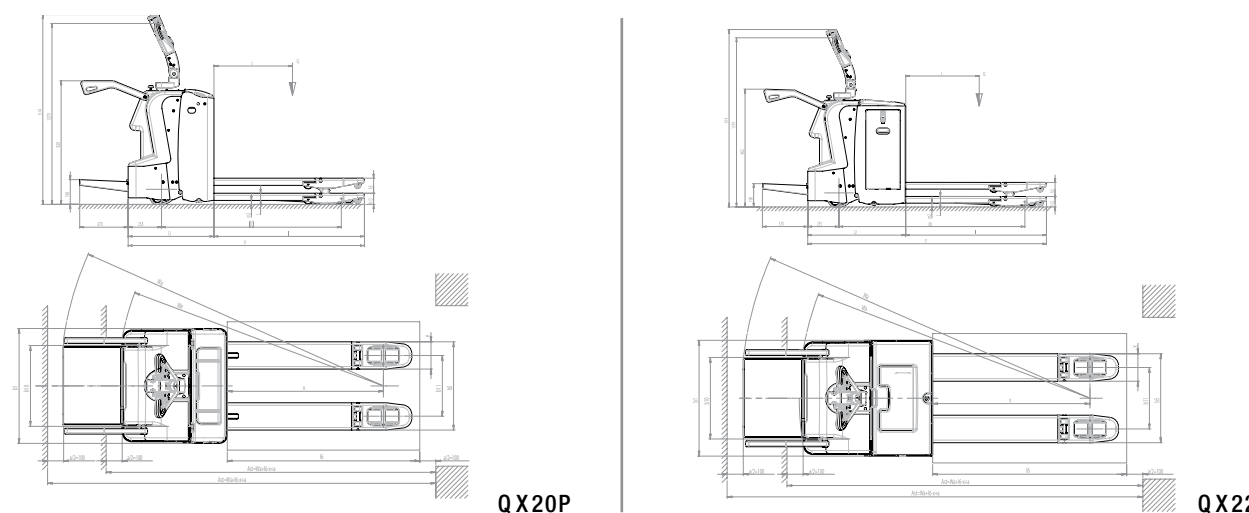
AC technology guarantees more energy efficiency and longer battery charging duration, thus reducing maintenance cost. Furthermore the absence of brushes in the motor and the simpler motor structure increase system reliability.

**PROLIFT** **QX 20P – 22**  
HANDLING LTD

QX models equipped with a footplate are highly versatile electrical pallet trucks which, thanks to their folding footplate, can be used in confined spaces or over medium distances with an excellent shift speed (8 - 10 km/h). The strong frame, the separately excited traction motor technology and the braking system with energy recovery are just few samples of the high technology of this machine.

**QX22**

The QX22 is ideal to move loads rapidly and over long distances. Structural solidity, quality of components, elevated load capacity (2.2 T), excellent shift speed (10 km/h) and battery capacity (315 ah) make QX22 the best choice for those who work on different shifts.



QX20P

QX22

| DESCRIPTION   | QX20P S2-S4            | QX22 S2-S4          |
|---|------------------------|---------------------|
| 1.2 MODEL   | QX20P S2-S4            | QX22 S2-S4          |
| 1.3 DRIVE   | ELECTRIC               | ELECTRIC            |
| 1.4 OPERATOR TYPE   | PEDESTRIAN/STANDING    | PEDESTRIAN/STANDING |
| 1.5 LOAD CAPACITY   | Q kg 2000              | 2200                |
| 1.6 LOAD CENTRE DISTANCE  | c mm 600               | 600                 |
| 1.8 LOAD DISTANCE, CENTRE OF DRIVE AXLE TO FORK                             | x mm 973               | 973                 |
| 1.9 WHEEL BASE  | y mm 1373              | 1520                |
| <b>WEIGHTS</b>  |                        |                     |
| 2.1 SERVICE WEIGHT WITH BATTERY (see line 6,5)                              | kg 559-564             | 632-637             |
| 2.2 AXLE LOAD LADEN, FRONT/REAR   | kg 1582-1587/977       | 1872-1877/960       |
| 2.3 AXLE LOAD UNLADEN, FRONT/REAR   | kg 117-122/442         | 190-195/442         |
| <b>TYRES/CHASSIS</b>  |                        |                     |
| 3.1 TYRES   | P/P+P                  | P/P+P               |
| 3.2 TYRE SIZE, FRONT (Ø x width)  | 85x90-80               | 85x90-80            |
| 3.3 TYRE SIZE, REAR (Ø x width)   | 230x75                 | 230x75              |
| 3.4 SIDE WHEELS (Ø x width)   | 100x40                 | 100x40              |
| 3.5 WHEELS, NUMBER (x=DRIVEN) FRONT/REAR                                    | 2/4 - 1x+2             | 2/4 - 1x+2          |
| 3.6 TREAD, FRONT  | b10 mm 380             | 380                 |
| 3.7 TREAD, REAR   | b11 mm 506             | 506                 |
| <b>DIMENSIONS</b>   |                        |                     |
| 4.4 LIFT  | h3 mm 115              | 115                 |
| 4.9 HEIGHT OF TILLER IN DRIVE POSITION MIN/MAX                              | h14 mm 1107/1450       | 1107/1450           |
| 4.15 HEIGHT, LOWERED  | h13 mm 85              | 85                  |
| 4.19 OVERALL LENGTH (PLATFORM CLOSED/OPEN)                                  | l1 mm 1806/2176        | 1950/2320           |
| 4.20 LENGTH TO FACE OF FORKS (PLATFORM CLOSED/OPEN)                         | l2 mm 656/1026         | 800/1170            |
| 4.21 OVERALL WIDTH  | b1 mm 716              | 716                 |
| 4.22 FORK DIMENSIONS  | s/e/l mm 55/170/1150   | 55/170/1150         |
| 4.25 DISTANCE BETWEEN FORK ARMS   | b5 mm 550              | 550                 |
| 4.32 GROUND CLEARANCE, CENTRE OF WHEEL BASE                                 | m2 mm 30               | 30                  |
| 4.34 AISLE WIDTH FOR PALLETES 800x1200 LENGTHWISE (PLATFORM CLOSED/OPEN)    | Ast mm 2084/2442       | 2225/2582           |
| 4.35 TURNING RADIUS (PLATFORM CLOSED/OPEN)                                  | Wa mm 1657/2015        | 1798/2155           |
| <b>PERFORMANCE DATA</b>   |                        |                     |
| 5.1 TRAVEL SPEED, LADEN/UNLADEN (PLATFORM CLOSED/OPEN)                      | km/h 6,0/6,0 (8,0/8,0) | 6,0/6,0 (10,0/10,0) |
| 5.2 LIFT SPEED, LADEN/UNLADEN   | m/s 0,04/0,05          | 0,04/0,05           |
| 5.3 LOWERING SPEED, LADEN/UNLADEN   | m/s 0,05/0,04          | 0,05/0,04           |
| 5.8 MAX GRADEABILITY, LADEN/UNLADEN   | 8/20                   | 8/20                |
| 5.10 SERVICE BRAKE  | ELECTRIC               | ELECTRIC            |
| <b>ELECTRIC MOTORS</b>  |                        |                     |
| 6.1 DRIVE MOTOR POWER   | kW 2                   | 2                   |
| 6.2 LIFT MOTOR POWER  | kW 2,2                 | 2,2                 |
| 6.4 BATTERY VOLTAGE, NOMINAL CAPACITY C5                                    | V/Ah 24/180            | 24/230              |
| 6.5 BATTERY WEIGHT  | kg 190                 | 216                 |
| 8.4 SOUND LEVEL AT DRIVER'S EAR   | dB(A) 56,4             | 56,4                |
| <i>G = Rubber, N = Nylon, P = Polyurethane, A = Steel, NE = Nylon extra</i> |                        |                     |
| <b>MODEL</b>  |                        |                     |
| FORK LENGTH   | l mm 1000              | 1000                |
| LOAD CENTRE DISTANCE  | c mm 500               | 500                 |
| OVERALL LENGTH (PLATFORM CLOSED/OPEN)                                       | l1 mm 1656/2026        | 1800/2170           |
| WHEEL BASE  | y mm 1223              | 1370                |
| LOAD DISTANCE, CENTRE OF DRIVE AXLE TO FORK                                 | x mm 823               | 823                 |
| SERVICE WEIGHT WITH BATTERY (see line 6,5)                                  | kg 551-556             | 624-629             |
| AXLE LOAD LADEN, FRONT/REAR   | kg 1581-1586/970       | 1869-1874/955       |
| AXLE LOAD UNLADEN, FRONT/REAR   | kg 116-121/435         | 187-192/437         |
| TURNING RADIUS (PLATFORM CLOSED/OPEN)                                       | Wa mm 1507/1865        | 1648/2005           |
| AISLE WIDTH FOR PALLETES 800x1200 LENGTHWISE (PLATFORM CLOSED/OPEN)         | Ast mm 1884/2242       | 2025/2382           |
| <b>BATTERY QX20P</b>  |                        |                     |
| BATTERY VOLTAGE, NOMINAL CAPACITY C5  | V/Ah 24/180            | 24/230              |
| BATTERY WEIGHT  | kg 185                 | 218                 |
| <b>BATTERY QX22</b>   |                        |                     |
| BATTERY VOLTAGE, NOMINAL CAPACITY C5  | V/Ah 24/230            | 24/315              |
| BATTERY WEIGHT  | kg 218                 | 280                 |



**Wheels**

- Wheel drive of considerable power (2 kW) and big size (Ø mm 230x75).
- Two stabilizing wheels enable movement even on more difficult surfaces, ensuring maximum stability in any condition of use.



**Replacement of Batteries**

The battery compartment is equipped with a removable side frame and an internal roller that minimizes effort during the battery extraction and connection phases. A trolley is also available upon request to replace the battery rapidly.



**Technology and Safety**

The machine is equipped with 3 sensors that automatically adjust speed control and reduce it up to 6 km/h when at least one of the following events occurs:

1. Lateral protection guards are not raised and are not brought to the "run" position.
2. The turning radius sensor registers a curve with an angle over 8 degrees.
3. The footplate is kept in closed position.



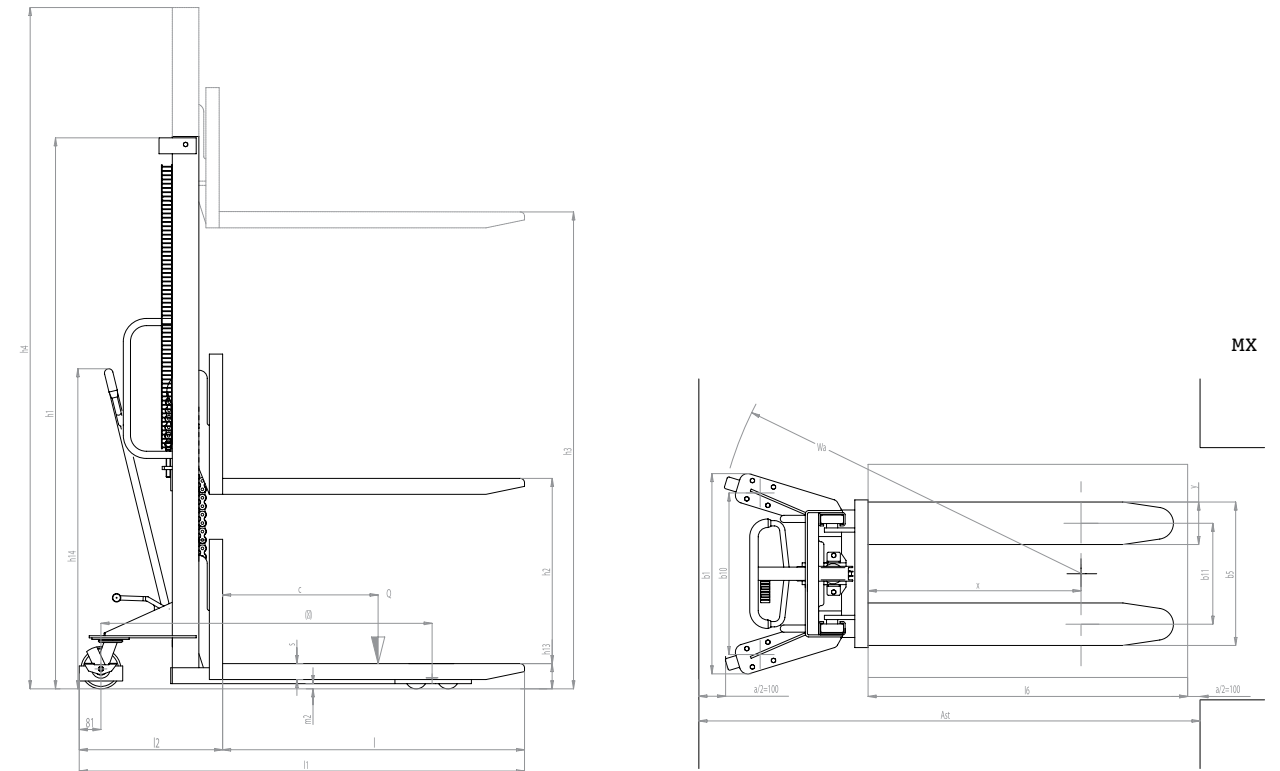
**Motors**

Lifting (2.2 kW) and traction (2 kW) motors have both a voltage of 24 Volt. The vertical assembly not only allows for a more rapid access to all the parts but also minimizes room cluttering-up and wiring stress. Separately excited traction motor (SEM) technology ensures speed which is independent from the load carried, while electronic control (MOSFET) allows for a better traction adjustment and a smoother and more progressive speed control. Furthermore the machine is equipped with a microswitch that protects the battery, avoiding energy waste, once the forks are brought to the maximum height.



**MX**

MX Series is not only an excellent compromise between price and performance but also a very resistant machine. Reinforced forks, steel pulley and forks precisely driven by rollers, are some of the main features of this stacker. The machine is also equipped with a foot pedal to lift forks, which considerably reduces the operator's effort.



| DESCRIPTION             |   |       |       | MX 510      | MX 516      | MX 1016     |
|-------------------------|---|-------|-------|-------------|-------------|-------------|
| 1.2                     | MODEL                                       |       |       | MX 510      | MX 516      | MX 1016     |
| 1.3                     | DRIVE                                       |       |       | MANUAL      | MANUAL      | MANUAL      |
| 1.4                     | OPERATOR TYPE                               |       |       | PEDESTRIAN  | PEDESTRIAN  | PEDESTRIAN  |
| 1.5                     | LOAD CAPACITY                               | Q     | kg    | 500         | 500         | 1000        |
| 1.6                     | LOAD CENTRE DISTANCE                        | c     | mm    | 600         | 600         | 600         |
| 1.8                     | LOAD DISTANCE, CENTRE OF DRIVE AXLE TO FORK | x     | mm    | 800         | 800         | 800         |
| 1.9                     | WHEEL BASE                                  | y     | mm    | 1240        | 1240        | 1240        |
| <b>WEIGHTS</b>          |   |       |       |             |             |             |
| 2.1                     | SERVICE WEIGHT WITH BATTERY                 |       | kg    | 185         | 200         | 210         |
| 2.2                     | AXLE LOAD LADEN, FRONT/REAR                 |       | kg    | 202/483     | 213/487     | 309/901     |
| 2.3                     | AXLE LOAD UNLADEN, FRONT/REAR               |       | kg    | 113/72      | 123/77      | 129/81      |
| <b>TYRES/CHASSIS</b>    |   |       |       |             |             |             |
| 3.1                     | TYRES                                       |       |       | N/N         | N/N         | N/N         |
| 3.2                     | TYRE SIZE, FRONT (Ø x width)                |       |       | 150x40      | 150x40      | 150x40      |
| 3.3                     | TYRE SIZE, REAR (Ø x width)                 |       |       | 80x70       | 80x70       | 80x70       |
| 3.5                     | WHEELS, NUMBER (x=DRIVEN) FRONT/REAR        |       |       | 2/2         | 2/2         | 2/2         |
| 3.6                     | TREAD, FRONT                                | b10   | mm    | 600         | 600         | 600         |
| 3.7                     | TREAD, REAR                                 | b11   | mm    | 380         | 380         | 380         |
| <b>DIMENSIONS</b>       |   |       |       |             |             |             |
| 4.2                     | HEIGHT, MAST LOWERED                        | h1    | mm    | 1490        | 2080        | 2080        |
| 4.3                     | FREE LIFT                                   | h2    | mm    | 910         | 1510        | 1510        |
| 4.4                     | LIFT  | h3    | mm    | 910         | 1510        | 1510        |
| 4.5                     | HEIGHT, MAST EXTENDED                       | h4    | mm    | 1490        | 2080        | 2080        |
| 4.9                     | HEIGHT OF TILLER IN DRIVE POSITION MIN/MAX  | h14   | mm    | 490/1090    | 490/1090    | 490/1090    |
| 4.15                    | HEIGHT, LOWERED                             | h13   | mm    | 90          | 90          | 90          |
| 4.19                    | OVERALL LENGTH                              | l1    | mm    | 1690        | 1690        | 1690        |
| 4.20                    | LENGTH TO FACE OF FORKS                     | l2    | mm    | 540         | 540         | 540         |
| 4.21                    | OVERALL WIDTH                               | b1/b2 | mm    | 740         | 740         | 740         |
| 4.22                    | FORK DIMENSIONS                             | s/e/l | mm    | 60/170/1150 | 60/170/1150 | 60/170/1150 |
| 4.24                    | FORK-CARRIAGE WIDTH                         | b3    | mm    | 550         | 550         | 550         |
| 4.25                    | DISTANCE BETWEEN FORK ARMS                  | b5    | mm    | 550         | 550         | 550         |
| 4.32                    | GROUND CLEARANCE, CENTRE OF WHEEL BASE      | m2    | mm    | 30          | 30          | 30          |
| 4.34                    | AISLE WIDTH FOR PALLETS 800x1200 LENGTHWISE | Ast   | mm    | 2166        | 2166        | 2166        |
| 4.35                    | TURNING RADIUS                              | Wa    | mm    | 1400        | 1400        | 1400        |
| <b>PERFORMANCE DATA</b> |   |       |       |             |             |             |
| 5.2                     | LIFT SPEED, LADEN/UNLADEN                   |       | m/s   | 37/37       | 73/73       | 73/73       |
| 5.3                     | LOWERING SPEED, LADEN/UNLADEN               |       | m/s   | 0.16/0.05   | 0.16/0.05   | 0.12/0.03   |
| 5.10                    | SERVICE BRAKE                               |       |       | -           | -           | -           |
| <b>ELECTRIC MOTORS</b>  |   |       |       |             |             |             |
| 6.2                     | LIFT MOTOR POWER                            |       | kW    | -           | -           | -           |
| 6.4                     | BATTERY VOLTAGE, NOMINAL CAPACITY C5        |       | V/Ah  | -           | -           | -           |
| 6.5                     | BATTERY WEIGHT                              |       | kg    | -           | -           | -           |
| 8.4                     | SOUND LEVEL AT DRIVER'S EAR                 |       | dB(A) | -           | -           | -           |

G = Rubber, N = Nylon, P = Polyurethane, A = Steel, NE = Nylon extra

**Steel Pulley**

A big chain and a strong steel pulley ensure great resistance and reliability even working with the max load capacity.

**Foot Brake**

The foot brake performs the parking brake function.

**Tiller**

The plastic cover increases the ergonomic character of the MX handle, rendering the raising and transport operations even "lighter". The 3-position control lever (down, neutral, up) is placed on the steering wheel to foster manoeuvrability.

**Max Pressure Valve**

When maximum load capacity is exceeded, the oil pressure exceeds its maximum limit and the valve automatically stops the forks from lifting. In this way, possible structural damage is avoided.

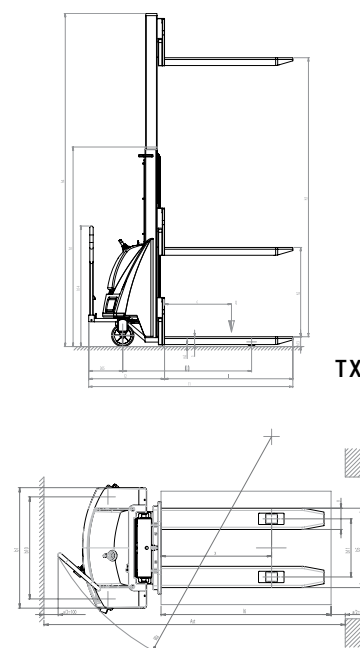


**PROLIFT TX**  
HANDLING LTD

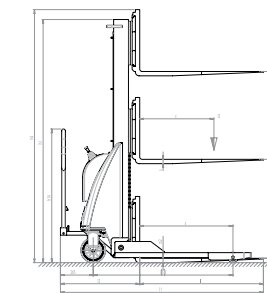
The TX Series are characterized by manual traction and electrohydraulic lifting technology. Version 12 (1.2t) includes polyurethane wheels as standard to reduce resistance and effort required even with full load capacity.

**TX/Straddle**

The main feature of the straddle series, which is available for the TX models, gives the possibility to adjust forks and clamps for great versatility in the handling of loads of different sizes.



TX



TX STRADDLE

Integrated battery and battery charger



**Start Key and Battery Cut-Off (Isolator) Switch**

The start key on the TX stacker performs a double function:

- It switches the stacker on/off
- is an emergency control, i.e. it completely stops battery power supply and thus prevents the lifting of forks.



**Foot Brake**

The foot brake performs the parking brake function.



**Adjustable Buffers**

The TX 12 is equipped with adjustable buffers that minimize possible oscillation during lifting.

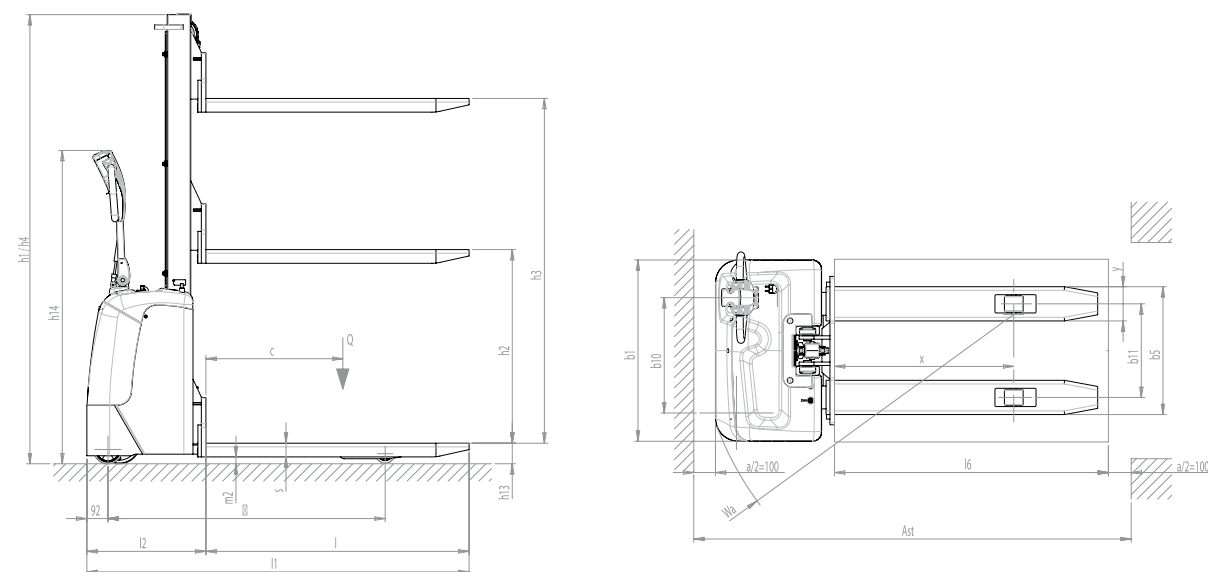
| DESCRIPTION                                      |          | TX 10/20    | TX 12/35    | TX 10/16 STRADDLE |
|--|----------|-------------|-------------|-------------------|
| 1.2 MODEL  |          | TX 10/20    | TX 12/35    | TX 10/16 STRADDLE |
| 1.3 DRIVE  |          | MANUAL      | MANUAL      | MANUAL            |
| 1.4 OPERATOR TYPE                                |          | PEDESTRIAN  | PEDESTRIAN  | PEDESTRIAN        |
| 1.5 LOAD CAPACITY                                | Q kg     | 1000        | 1200        | 1000              |
| 1.6 LOAD CENTRE DISTANCE                         | c mm     | 600         | 600         | 600               |
| 1.8 LOAD DISTANCE, CENTRE OF DRIVE AXLE TO FORK  | x mm     | 630         | 780         | 755               |
| 1.9 WHEEL BASE                                   | y mm     | 965         | 1155        | 1130              |
| <b>WEIGHTS</b>                                   |          |             |             |                   |
| 2.1 SERVICE WEIGHT WITH BATTERY                  | kg       | 321         | 474         | 415               |
| 2.2 AXLE LOAD LADEN, FRONT/REAR                  | kg       | 253/1068    | 537/1137    | 453/962           |
| 2.3 AXLE LOAD UNLADEN, FRONT/REAR                | kg       | 222/99      | 345/129     | 270/145           |
| <b>TYRES/CHASSIS</b>                             |          |             |             |                   |
| 3.1 TYRES  |          | G/N         | P/N         | G/N               |
| 3.2 TYRE SIZE, FRONT (Ø x width)                 |          | 200x50      | 200x50      | 200x50            |
| 3.3 TYRE SIZE, REAR (Ø x width)                  |          | 82x70       | 82x70       | 82x70             |
| 3.5 WHEELS, NUMBER (x=DRIVEN) FRONT/REAR         |          | 2/2         | 2/2         | 2/2               |
| 3.6 TREAD, FRONT                                 | b10 mm   | 620         | 720         | 620               |
| 3.7 TREAD, REAR                                  | b11 mm   | 410         | 410         | 1080/1387         |
| <b>DIMENSIONS</b>                                |          |             |             |                   |
| 4.2 HEIGHT, MAST LOWERED                         | h1 mm    | 2370        | 2250        | 1970              |
| 4.3 FREE LIFT                                    | h2 mm    | 1910        | 80          | 1510              |
| 4.4 LIFT   | h3 mm    | 1910        | 3410        | 1510              |
| 4.5 HEIGHT, MAST EXTENDED                        | h4 mm    | 2370        | 3915        | 2045              |
| 4.9 HEIGHT OF TILLER IN DRIVE POSITION MIN/MAX   | h14 mm   | 60/1080     | 60/1080     | 60/1080           |
| 4.15 HEIGHT, LOWERED                             | h13 mm   | 90          | 90          | 35                |
| 4.19 OVERALL LENGTH                              | l1 mm    | 1750        | 1850        | 1640              |
| 4.20 LENGTH TO FACE OF FORKS                     | l2 mm    | 600         | 700         | 640               |
| 4.21 OVERALL WIDTH                               | b1/b2 mm | 750         | 850         | 750/1199-1504     |
| 4.22 FORK DIMENSIONS                             | s/e/l mm | 70/150/1150 | 70/150/1150 | 35/100/1000       |
| 4.24 FORK-CARRIAGE WIDTH                         | b3 mm    | 650         | 650         | 825               |
| 4.25 DISTANCE BETWEEN FORK ARMS                  | b5 mm    | 560         | 560         | 230/790           |
| 4.26 DISTANCE BETWEEN LEGS MIN/MAX               | b4 mm    | -           | -           | 965/1270          |
| 4.32 GROUND CLEARANCE, CENTRE OF WHEEL BASE      | m2 mm    | 20          | 20          | 40                |
| 4.34 AISLE WIDTH FOR PALLETS 800x1200 LENGTHWISE | Ast mm   | 2336        | 2540        | 2588              |
| 4.35 TURNING RADIUS                              | Wa mm    | 1440        | 1760        | 1790              |
| <b>PERFORMANCE DATA</b>                          |          |             |             |                   |
| 5.2 LIFT SPEED, LADEN/UNLADEN                    | m/s      | 0,09/0,12   | 0,09/0,12   | 0,09/0,12         |
| 5.3 LOWERING SPEED, LADEN/UNLADEN                | m/s      | 0,4/0,1     | 0,4/0,1     | 0,4/0,1           |
| 5.10 SERVICE BRAKE                               |          | -           | -           | MANUAL            |
| <b>ELECTRIC MOTORS</b>                           |          |             |             |                   |
| 6.2 LIFT MOTOR POWER                             | kW       | 1,6         | 2,2         | 1,6               |
| 6.4 BATTERY VOLTAGE, NOMINAL CAPACITY C5         | V/Ah     | 12/70 (C20) | 24/70 (C20) | 12/70 (C20)       |
| 6.5 BATTERY WEIGHT                               | kg       | 16          | 32          | 32                |
| 8.4 SOUND LEVEL AT DRIVER'S EAR                  | dB(A)    | 67          | 67          | 67                |

G = Rubber, N = Nylon, P = Polyurethane, A = Steel, NE = Nylon extra

| MODEL                                     |       | TX 10/09 | TX 10/16 | TX 12/25 | TX 12/29 |
|---|-------|----------|----------|----------|----------|
| LIFT                                      | h3 mm | 810      | 1510     | 2410     | 2810     |
| HEIGHT, MAST LOWERED                      | h1 mm | 1300     | 1970     | 1780     | 1980     |
| FREE LIFT                                 | h2 mm | 810      | 1510     | -        | -        |
| HEIGHT, MAST EXTENDED                     | h4 mm | 1300     | 1970     | 2985     | 3385     |
| SERVICE WEIGHT WITH BATTERY (SEE ROW 6.5) | kg    | 296      | 311      | 415      | 431      |
| AXLE LOAD LADEN, FRONT/REAR               | kg    | 228/1068 | 241/1070 | 493/1122 | 502/1129 |
| AXLE LOAD UNLADEN, FRONT/REAR             | kg    | 197/99   | 210/101  | 301/114  | 310/121  |

**RX**

RX is the most compact in the stackers' range, single mast, completely electric, suitable for loads up to 1.000 kg and elevation up to 1.600 mm, allowing a comfortable, safe use, with low maintenance costs, thanks to robust design with easy access for maintenance. RX combines compactness and ergonomics, offering a wide range of applications distribution and manufacturing environments and it is not intended for continuous daily activity.



| DESCRIPTION                                      |          | RX 10/16    | RX 10/16 "PLUS" | RX 10/16 "GEL" |
|--|----------|-------------|-----------------|----------------|
| 1.2 MODEL  |          | RX 10/16    | RX 10/16 "PLUS" | RX 10/16 "GEL" |
| 1.3 DRIVE  |          | ELECTRIC    | ELECTRIC        | ELECTRIC       |
| 1.4 OPERATOR TYPE                                |          | PEDESTRIAN  | PEDESTRIAN      | PEDESTRIAN     |
| 1.5 LOAD CAPACITY                                | Q kg     | 1000        | 1000            | 1000           |
| 1.6 LOAD CENTRE DISTANCE                         | c mm     | 600         | 600             | 600            |
| 1.8 LOAD DISTANCE, CENTRE OF DRIVE AXLE TO FORK  | x mm     | 786         | 786             | 786            |
| 1.9 WHEEL BASE                                   | y mm     | 1165        | 1165            | 1165           |
| <b>WEIGHTS</b>                                   |          |             |                 |                |
| 2.1 SERVICE WEIGHT WITH BATTERY (SEE ROW 6.5)    | kg       | 363         | 371             | 371            |
| 2.2 AXLE LOAD LADEN, FRONT/REAR                  | kg       | 426/937     | 434/937         | 434/937        |
| 2.3 AXLE LOAD UNLADEN, FRONT/REAR                | kg       | 261/102     | 269/102         | 269/102        |
| <b>TYRES/CHASSIS</b>                             |          |             |                 |                |
| 3.1 TYRES  |          | G+P/P       | G+P/P           | G+P/P          |
| 3.2 TYRE SIZE, FRONT (Ø x width)                 |          | 186x50      | 186x50          | 186x50         |
| 3.3 TYRE SIZE, REAR (Ø x width)                  |          | 82x70       | 82x70           | 82x70          |
| 3.4 SIDE WHEELS (Ø x width)                      |          | 125x45      | 125x45          | 125x45         |
| 3.5 WHEELS, NUMBER (x=DRIVEN) FRONT/REAR         |          | 1x+1/2      | 1x+1/2          | 1x+1/2         |
| 3.6 TREAD, FRONT                                 | b10 mm   | 505         | 505             | 505            |
| 3.7 TREAD, REAR                                  | b11 mm   | 410         | 410             | 410            |
| <b>DIMENSIONS</b>                                |          |             |                 |                |
| 4.2 HEIGHT, MAST LOWERED                         | h1 mm    | 1970        | 1970            | 1970           |
| 4.3 FREE LIFT                                    | h2 mm    | 1510        | 1510            | 1510           |
| 4.4 LIFT   | h3 mm    | 1510        | 1510            | 1510           |
| 4.5 HEIGHT, MAST EXTENDED                        | h4 mm    | 1970        | 1970            | 1970           |
| 4.9 HEIGHT OF TILLER IN DRIVE POSITION MIN/MAX   | h14 mm   | 930/1365    | 930/1365        | 930/1365       |
| 4.15 HEIGHT, LOWERED                             | h13 mm   | 90          | 90              | 90             |
| 4.19 OVERALL LENGTH                              | l1 mm    | 1675        | 1675            | 1675           |
| 4.20 LENGTH TO FACE OF FORKS                     | l2 mm    | 522         | 522             | 522            |
| 4.21 OVERALL WIDTH                               | b1 mm    | 794         | 794             | 794            |
| 4.22 FORK DIMENSIONS                             | s/e/l mm | 60/150/1153 | 60/150/1153     | 60/150/1153    |
| 4.24 FORK-CARRIAGE WIDTH                         | b3 mm    | 650         | 650             | 650            |
| 4.25 DISTANCE BETWEEN FORK ARMS                  | b5 mm    | 560         | 560             | 560            |
| 4.32 GROUND CLEARANCE, CENTRE OF WHEEL BASE      | m2 mm    | 20          | 20              | 20             |
| 4.34 AISLE WIDTH FOR PALLETS 800x1200 LENGTHWISE | Ast mm   | 2120        | 2120            | 2120           |
| 4.35 TURNING RADIUS                              | Wa mm    | 1344        | 1344            | 1344           |
| <b>PERFORMANCE DATA</b>                          |          |             |                 |                |
| 5.1 TRAVEL SPEED, LADEN/UNLADEN                  | km/h     | 3,7/4,3     | 3,7/4,3         | 3,7/4,3        |
| 5.2 LIFT SPEED, LADEN/UNLADEN                    | m/s      | 0,11/0,18   | 0,11/0,18       | 0,11/0,18      |
| 5.3 LOWERING SPEED, LADEN/UNLADEN                | m/s      | 0,18/0,18   | 0,18/0,18       | 0,18/0,18      |
| 5.8 MAX GRADEABILITY, LADEN/UNLADEN              | %        | 9/25        | 9/25            | 9/25           |
| 5.10 SERVICE BRAKE                               |          | ELECTRIC    | ELECTRIC        | ELECTRIC       |
| <b>ELECTRIC MOTORS</b>                           |          |             |                 |                |
| 6.1 DRIVE MOTOR POWER                            | kW       | 0,35        | 0,35            | 0,35           |
| 6.2 LIFT MOTOR POWER                             | kW       | 2,2         | 2,2             | 2,2            |
| 6.4 BATTERY VOLTAGE, NOMINAL CAPACITY C5         | V/Ah     | 24/70 (C20) | 24/54           | 24/50          |
| 6.5 BATTERY WEIGHT                               | kg       | 32          | 38              | 38             |
| 8.4 SOUND LEVEL AT DRIVER'S EAR                  | dB(A)    | 63          | 63              | 63             |

G = Rubber, N = Nylon, P = Polyurethane, A = Steel, NE = Nylon extra

**EAST MAINTENANCE**

Strong ABS carter/cover with storage compartments on top, easily removable to speed up maintenance operations. The bottom access opening allows an immediate disassembly of motor wheel, portal and tiller without lifting the machine.


**Ergonomics**

Ergonomic tiller placed laterally to increase visibility, ensuring an optimal arrangement of components inside the motor compartment. RX 10/16 solves perfectly the problem of handling goods in narrow spaces and corridors

**Versatility**

It's ideal to move, even horizontally, palletized goods and at the same time it can be used as an adjustable worktable, reducing stress for the operator who must place goods on a shelf. Forks thickness 60 mm for an easier entrance inside pallet, while working in elevation.


**Battery Pack**

Starting batteries (light-traction PLUS or GEL type as option), lightweight and inexpensive, allow up to 3 hours autonomy.

**PROLIFT** **GX**  
HANDLING LTD

This compact sized stacker is the ideal solution to work in confined spaces and looks both powerful and reliable. The use of high resistance steel, the numerous parts made of cast iron and the abs protection guard are some of the main features of this machine. The GX10 series is also characterized by simplex masts with a capacity of 1.000 Kg while the GX12 version is equipped with duplex masts for a lift height up to 3.500 mm.

**GX/Straddle**

The main feature of the straddle series is the possibility to adjust the forks and the clamps for greater versatility in the handling of loads of different sizes.

**GX/Free Lift**

This stacker combines the characteristics of the gx series with the total free lift, allowing lifting forks up to 1472 mm from the ground without increasing the minimum machine bulk (1.967 mm). For this reason the truck can also be used in working spaces with reduced height.

**GX/Plus**

The GX Series is available in the plus version with a more powerful battery and the gel version with a gel battery. The battery of the plus model also allows for a greater number of charging cycles and longer autonomy.



**PLUS**  
**GX 12**

Integrated battery and battery charger. Available with double lifting command. Available with poly motorwheel ring.



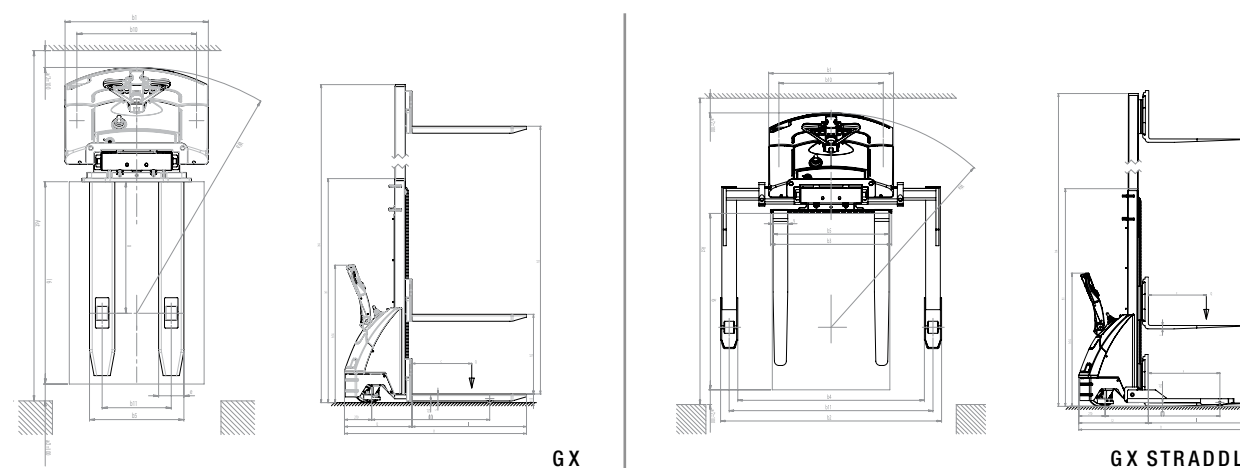
**Tiller**

- Butterfly valve for traction control
- Safety pushbutton with warning buzzer
- Luminous display for battery state control
- Hour counter (version Plus and Gel)
- Possibility of fork lifting double control



**Protection Guard**

The ABS "double" guard is synonymous of reliability and practical convenience. The removal of the only lower part ensures rapidity in the ordinary maintenance operations. Finally the particular thickness of the guard makes the machine even stronger.



| DESCRIPTION                                      |          | GX 10/09    | GX 10/16    | GX 10/20    | GX 12/25    | GX 12/29    | GX 12/35    |
|--|----------|-------------|-------------|-------------|-------------|-------------|-------------|
| 1.2 MODEL  |          | ELECTRIC    | ELECTRIC    | ELECTRIC    | ELECTRIC    | ELECTRIC    | ELECTRIC    |
| 1.3 DRIVE  |          | PEDESTRIAN  | PEDESTRIAN  | PEDESTRIAN  | PEDESTRIAN  | PEDESTRIAN  | PEDESTRIAN  |
| 1.4 OPERATOR TYPE                                |          | Q           | Q           | Q           | Q           | Q           | Q           |
| 1.5 LOAD CAPACITY                                | kg       | 1000        | 1000        | 1000        | 1200        | 1200        | 1200        |
| 1.6 LOAD CENTRE DISTANCE                         | c mm     | 600         | 600         | 600         | 600         | 600         | 600         |
| 1.8 LOAD DISTANCE, CENTRE OF DRIVE AXLE TO FORK  | x mm     | 785         | 785         | 785         | 785         | 785         | 785         |
| 1.9 WHEEL BASE                                   | y mm     | 1185        | 1185        | 1185        | 1185        | 1185        | 1185        |
| <b>WEIGHTS</b>                                   |          |             |             |             |             |             |             |
| 2.1 SERVICE WEIGHT WITH BATTERY (SEE ROW 6.5)    | kg       | 372         | 393         | 413         | 481         | 496         | 531         |
| 2.2 AXLE LOAD LADEN, FRONT/REAR                  | kg       | 428/944     | 443/950     | 457/956     | 545/1136    | 559/1137    | 585/1146    |
| 2.3 AXLE LOAD UNLADEN, FRONT/REAR                | kg       | 273/99      | 288/105     | 302/111     | 358/123     | 372/124     | 398/133     |
| <b>TYRES/CHASSIS</b>                             |          |             |             |             |             |             |             |
| 3.1 TYRES  |          | G+P/P       | G+P/P       | G+P/P       | G+P/P       | G+P/P       | G+P/P       |
| 3.2 TYRE SIZE, FRONT (Ø x width)                 |          | 240x60      | 240x60      | 240x60      | 250x76      | 250x76      | 250x76      |
| 3.3 TYRE SIZE, REAR (Ø x width)                  |          | 82x70       | 82x70       | 82x70       | 82x70       | 82x70       | 82x70       |
| 3.4 SIDE WHEELS (Ø x width)                      |          | 150x40      | 150x40      | 150x40      | 150x40      | 150x40      | 150x40      |
| 3.5 WHEELS, NUMBER (x=DRIVEN) FRONT/REAR         |          | 1x+2/2      | 1x+2/2      | 1x+2/2      | 1x+2/2      | 1x+2/2      | 1x+2/2      |
| 3.6 TREAD, FRONT                                 | b10 mm   | 710         | 710         | 710         | 710         | 710         | 710         |
| 3.7 TREAD, REAR                                  | b11 mm   | 410         | 410         | 410         | 410         | 410         | 410         |
| <b>DIMENSIONS</b>                                |          |             |             |             |             |             |             |
| 4.2 HEIGHT, MAST LOWERED                         | h1 mm    | 1300        | 1970        | 2370        | 1780        | 1980        | 2250        |
| 4.3 FREE LIFT                                    | h2 mm    | 810         | 1510        | 1910        | -           | -           | 80          |
| 4.4 LIFT   | h3 mm    | 810         | 1510        | 1910        | 2410        | 2810        | 3410        |
| 4.5 HEIGHT, MAST EXTENDED                        | h4 mm    | 1300        | 1970        | 2370        | 2985        | 3385        | 3915        |
| 4.6 INITIAL LIFT                                 | h5 mm    | -           | -           | -           | -           | -           | -           |
| 4.9 HEIGHT OF TILLER IN DRIVE POSITION MIN/MAX   | h14 mm   | 990/1390    | 990/1390    | 990/1390    | 990/1390    | 990/1390    | 990/1390    |
| 4.15 HEIGHT, LOWERED                             | h13 mm   | 90          | 90          | 90          | 90          | 90          | 90          |
| 4.19 OVERALL LENGTH                              | l1 mm    | 1825        | 1825        | 1825        | 1825        | 1825        | 1825        |
| 4.20 LENGTH TO FACE OF FORKS                     | l2 mm    | 675         | 675         | 675         | 675         | 675         | 675         |
| 4.21 OVERALL WIDTH                               | b1/b2 mm | 850         | 850         | 850         | 850         | 850         | 850         |
| 4.22 FORK DIMENSIONS                             | s/e/l mm | 70/150/1150 | 70/150/1150 | 70/150/1150 | 70/150/1150 | 70/150/1150 | 70/150/1150 |
| 4.24 FORK-CARRIAGE WIDTH                         | b3 mm    | 650         | 650         | 650         | 650         | 650         | 650         |
| 4.25 DISTANCE BETWEEN FORK ARMS                  | b5 mm    | 560         | 560         | 560         | 560         | 560         | 560         |
| 4.32 GROUND CLEARANCE, CENTRE OF WHEEL BASE      | m2 mm    | 20          | 20          | 20          | 20          | 20          | 20          |
| 4.34 AISLE WIDTH FOR PALLETS 800x1200 LENGTHWISE | Ast mm   | 2236        | 2236        | 2236        | 2236        | 2236        | 2236        |
| 4.35 TURNING RADIUS                              | Wa mm    | 1460        | 1460        | 1460        | 1460        | 1460        | 1460        |
| <b>PERFORMANCE DATA</b>                          |          |             |             |             |             |             |             |
| 5.1 TRAVEL SPEED, LADEN/UNLADEN                  | km/h     | 4/5         | 4/5         | 4/5         | 4/5         | 4/5         | 4/5         |
| 5.2 LIFT SPEED, LADEN/UNLADEN                    | m/s      | 0.09/0.12   | 0.09/0.12   | 0.09/0.12   | 0.09/0.12   | 0.09/0.12   | 0.09/0.12   |
| 5.3 LOWERING SPEED, LADEN/UNLADEN                | m/s      | 0.4/0.1     | 0.4/0.1     | 0.4/0.1     | 0.4/0.1     | 0.4/0.1     | 0.4/0.1     |
| 5.8 MAX GRADEABILITY, LADEN/UNLADEN              | %        | 5/10        | 5/10        | 5/10        | 5/10        | 5/10        | 5/10        |
| 5.10 SERVICE BRAKE                               |          | ELECTRIC    | ELECTRIC    | ELECTRIC    | ELECTRIC    | ELECTRIC    | ELECTRIC    |
| <b>ELECTRIC MOTORS</b>                           |          |             |             |             |             |             |             |
| 6.1 DRIVE MOTOR POWER                            | kW       | 0.5         | 0.5         | 0.5         | 0.7         | 0.7         | 0.7         |
| 6.2 LIFT MOTOR POWER                             | kW       | 2.2         | 2.2         | 2.2         | 2.2         | 2.2         | 2.2         |
| 6.4 BATTERY VOLTAGE, NOMINAL CAPACITY C5         | V/Ah     | 24/70 (C20) | 24/70 (C20) | 24/70 (C20) | 24/88 (C20) | 24/88 (C20) | 24/88 (C20) |
| 6.5 BATTERY WEIGHT                               | kg       | 32          | 32          | 32          | 40          | 40          | 40          |
| 8.4 SOUND LEVEL AT DRIVER'S EAR                  | dB(A)    | 67          | 67          | 67          | 67          | 67          | 67          |

G = Rubber, N = Nylon, P = Polyurethane, A = Steel, NE = Nylon extra

| MODEL                                     |       | GX 12/25 PLUS | GX 12/29 PLUS | GX 12/35 PLUS | GX 12/28 FREE LIFT | GX 12/25 STRADDLE | GX 12/29 STRADDLE | GX 12/35 STRADDLE | GX 12/38 STRADDLE |
|---|-------|---------------|---------------|---------------|--------------------|-------------------|-------------------|-------------------|-------------------|
| LIFT                                      | h3 mm | 2410          | 2810          | 3410          | 2750               | 2410              | 2810              | 3410              | 3710              |
| HEIGHT, MAST LOWERED                      | h1 mm | 1780          | 1980          | 2250          | 1967               | 1780              | 1980              | 2250              | 2425              |
| FREE LIFT                                 | h2 mm | -             | -             | 80            | 1382               | -                 | -                 | 80                | 80                |
| HEIGHT, MAST EXTENDED                     | h4 mm | 2985          | 3385          | 3915          | 3335               | 2985              | 3385              | 3915              | 4270              |
| SERVICE WEIGHT WITH BATTERY (SEE ROW 6.5) | kg    | 515           | 530           | 565           | 508                | 565               | 580               | 615               | 665               |
| AXLE LOAD LADEN, FRONT/REAR               | kg    | 579/1136      | 593/1137      | 619/1146      | 564/1144           | 582/1183          | 596/1184          | 617/1198          | 656/1209          |
| AXLE LOAD UNLADEN, FRONT/REAR             | kg    | 392/123       | 406/124       | 432/133       | 381/127            | 380/185           | 394/186           | 426/189           | 464/201           |
| DISTANCE BETWEEN FORK ARMS MIN/MAX        | b5 mm | 560           | 560           | 560           | 560                | 230/790           | 230/790           | 230/790           | 230/790           |
| DISTANCE BETWEEN LEGS MIN/MAX             | b4 mm | -             | -             | -             | -                  | 965/1270          | 965/1270          | 965/1270          | 965/1270          |



**PROLIFT LX**  
HANDLING LTD

The new LX is a strong and reliable partner which bridges the gap between low-duty and heavy duty material handling daily operations. Due to its durability, low maintenance LX is suitable for environments as logistic centers, terminals, production and manufacturing areas. Also the new tiller arm equipped with fork lifting and lowering proportional control improves user-friendliness and maneuverability of the truck.

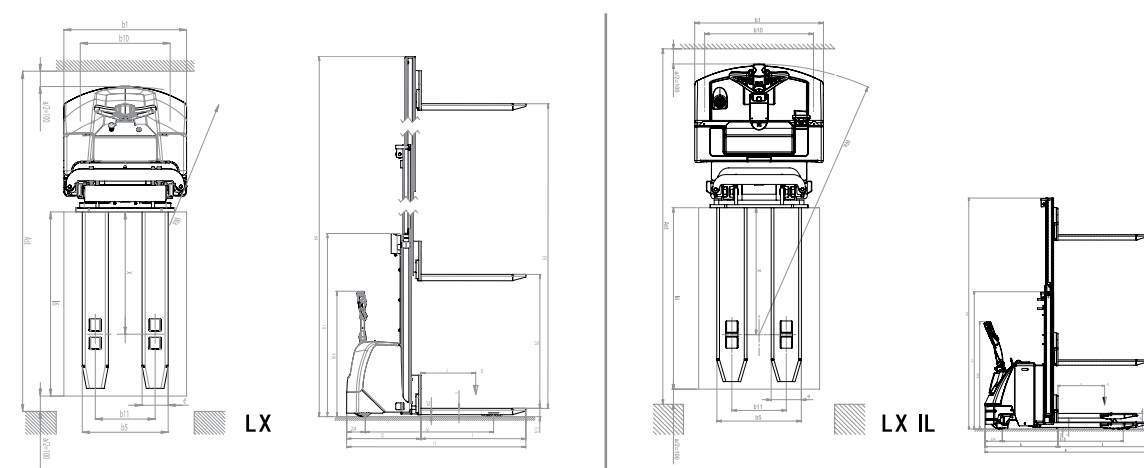
**LX/Initial lifting**

First Edition

Apart from the LX series high capacity characteristics, the initial lifting models also offer the possibility to lift legs, hence facilitating the overcoming of ramps and knick points. These models can also be used for the simultaneous transport of 2 pallets: one with the forks and onewith the clamps.



Flip down operator platform available. AC traction motor



| DESCRIPTION             |   | LX 14/45             | LX 12/25 INITIAL LIFTING | LX 14/29 INITIAL LIFTING | LX 16/29    | LX 12/29    |
|-------------------------|---|----------------------|--------------------------|--------------------------|-------------|-------------|
| 1.2                     | MODEL                                       | LX 14/45             | LX 12/25 INITIAL LIFTING | LX 14/29 INITIAL LIFTING | LX 16/29    | LX 12/29    |
| 1.3                     | DRIVE                                       | ELECTRIC             | ELECTRIC                 | ELECTRIC                 | ELECTRIC    | ELECTRIC    |
| 1.4                     | OPERATOR TYPE                               | PEDESTRIAN           | PEDESTRIAN               | PEDESTRIAN               | PEDESTRIAN  | PEDESTRIAN  |
| 1.5                     | LOAD CAPACITY                               | Q kg 1400            | 1200                     | 1400                     | 1600        | 1200        |
| 1.6                     | LOAD CENTRE DISTANCE                        | c mm 600             | 600                      | 600                      | 600         | 600         |
| 1.8                     | LOAD DISTANCE, CENTRE OF DRIVE AXLE TO FORK | x mm 797             | 840                      | 820                      | 820         | 780         |
| 1.9                     | WHEEL BASE                                  | y mm 1436            | 1555                     | 1555                     | 1436        | 1373        |
| <b>WEIGHTS</b>          |   |                      |                          |                          |             |             |
| 2.1                     | SERVICE WEIGHT WITH BATTERY (SEE LINE 6.5)  | kg 1190              | 947                      | 1080                     | 1050        | 837         |
| 2.2                     | AXLE LOAD LADEN, FRONT/REAR                 | kg 1002/1588         | 739/1408                 | 856/1624                 | 977/1673    | 794/1243    |
| 2.3                     | AXLE LOAD UNLADEN, FRONT/REAR               | kg 801/389           | 590/357                  | 674/406                  | 723/315     | 603/234     |
| <b>TYRES/CHASSIS</b>    |   |                      |                          |                          |             |             |
| 3.1                     | TYRES                                       | G+P/P                | G+P/P                    | G+P/P                    | G+P/P       | G+P/P       |
| 3.2                     | TYRE SIZE, FRONT (Ø x width)                | 250x101              | 250x76                   | 250x101                  | 250x101     | 250x76      |
| 3.3                     | TYRE SIZE, REAR (Ø x width)                 | 82x70                | 78x78                    | 78x78                    | 82x70       | 82x70       |
| 3.4                     | SIDE WHEELS (Ø x width)                     | 2 x 100x38           | 125x50                   | 125x50                   | 2 x 100x38  | 2 x 100x38  |
| 3.5                     | WHEELS, NUMBER (x=DRIVEN) FRONT/REAR        | 1x+2/4               | 1x+2/4                   | 1x+2/4                   | 1x+2/4      | 1x+2/2      |
| 3.6                     | TREAD, FRONT                                | b10 mm 586           | 720                      | 720                      | 586         | 586         |
| 3.7                     | TREAD, REAR                                 | b11 mm 390           | 360                      | 360                      | 390         | 390         |
| <b>DIMENSIONS</b>       |   |                      |                          |                          |             |             |
| 4.2                     | HEIGHT, MAST LOWERED                        | h1 mm 2080           | 1765                     | 1965                     | 1965        | 1985        |
| 4.3                     | FREE LIFT                                   | h2 mm -              | -                        | -                        | -           | -           |
| 4.4                     | LIFT  | h3 mm 4410           | 2410                     | 2810                     | 2810        | 2810        |
| 4.5                     | HEIGHT, MAST EXTENDED                       | h4 mm 5020           | 2970                     | 3370                     | 3370        | 3390        |
| 4.6                     | INITIAL LIFT                                | h5 mm -              | 120                      | 120                      | -           | -           |
| 4.9                     | HEIGHT OF TILLER IN DRIVE POSITION MIN/MAX  | h14 mm 990/1390      | 990/1390                 | 990/1390                 | 990/1390    | 990/1390    |
| 4.15                    | HEIGHT, LOWERED                             | h13 mm 90            | 90                       | 90                       | 90          | 90          |
| 4.19                    | OVERALL LENGTH                              | l1 mm 1966           | 2100 (2192/2603)         | 2110 (2202/2613)         | 1944        | 1920        |
| 4.20                    | LENGTH TO FACE OF FORKS                     | l2 mm 816            | 950 (1042/1453)          | 960 (1052/1463)          | 795         | 770         |
| 4.21                    | OVERALL WIDTH                               | b1 mm 800            | 850                      | 850                      | 800         | 800         |
| 4.22                    | FORK DIMENSIONS                             | s/e/l mm 70/170/1150 | 70/200/1150              | 70/200/1150              | 70/170/1150 | 70/150/1150 |
| 4.24                    | FORK-CARRIAGE WIDTH                         | b3 mm 644            | 650                      | 644                      | 644         | 650         |
| 4.25                    | DISTANCE BETWEEN FORK ARMS                  | b5 mm 560            | 560                      | 560                      | 560         | 560         |
| 4.32                    | GROUND CLEARANCE, CENTRE OF WHEEL BASE      | m2 mm 20             | 17/137                   | 17/137                   | 20          | 20          |
| 4.34                    | AISLE WIDTH FOR PALLET 800x1200 LENGTHWISE  | Ast mm 2380          | 2432 (2485/2942)         | 2446 (2499/2956)         | 2365        | 2330        |
| 4.35                    | TURNING RADIUS (PLATFORM CLOSED/OPEN)       | Wa mm 1613           | 1694 (1747/2204)         | 1694 (1747/2204)         | 1613        | 1550        |
| <b>PERFORMANCE DATA</b> |   |                      |                          |                          |             |             |
| 5.1                     | TRAVEL SPEED, LADEN/UNLADEN                 | km/h 6/6             | 5.5/6 (3.5/4)            | 5.5/6 (3.5/4)            | 6/6         | 6/6         |
| 5.2                     | LIFT SPEED, LADEN/UNLADEN                   | m/s 0,14/0,28        | 0,09/0,15                | 0,08/0,12                | 0,13/0,25   | 0,15/0,28   |
| 5.3                     | LOWERING SPEED, LADEN/UNLADEN               | m/s 0,34/0,40        | 0,4/0,1                  | 0,4/0,1                  | 0,31/0,38   | 0,31/0,16   |
| 5.8                     | MAX GRADEABILITY, LADEN/UNLADEN             | % 5/10               | 5/10                     | 5/10                     | 5/10        | 5/10        |
| 5.10                    | SERVICE BRAKE                               | ELECTRIC             | ELECTRIC                 | ELECTRIC                 | ELECTRIC    | ELECTRIC    |
| <b>ELECTRIC MOTORS</b>  |   |                      |                          |                          |             |             |
| 6.1                     | DRIVE MOTOR POWER                           | kW 1,2               | 1,2                      | 1,2                      | 1,2         | 1,2         |
| 6.2                     | LIFT MOTOR POWER                            | kW 3,2               | 2,5                      | 2,5                      | 3,2         | 2,2         |
| 6.4                     | BATTERY VOLTAGE, NOMINAL CAPACITY C5        | V/Ah 24/300          | 24/180                   | 24/180                   | 24/300      | 24/300      |
| 6.5                     | BATTERY WEIGHT                              | kg 270               | 200                      | 200                      | 270         | 270         |

| MODEL                                      | LX 12/16    | LX 12/25 | LX 12/35 | LX 12/38 | LX 14/42 | LX 14/42 FREE LIFT | LX 14/45 FREELIFT | LX 14/50 | LX 14/50 FREELIFT | LX 16/16 | LX 16/25 | LX 16/35  | LX 14/25 INITIAL LIFTING | LX 14/45 INITIAL LIFTING |
|--|-------------|----------|----------|----------|----------|--------------------|-------------------|----------|-------------------|----------|----------|-----------|--------------------------|--------------------------|
| SERVICE WEIGHT WITH BATTERY (SEE LINE 6.5) | 750         | 822      | 878      | 888      | 1172     | 1204               | 1223              | 1229     | 1262              | 920      | 1025     | 1090      | 1055                     | 1232                     |
| AXLE LOAD LADEN, FRONT/REAR                | 761/1190    | 789/1233 | 810/1268 | 814/1274 | 883/1689 | 902/1702           | 913/1710          | 916/1713 | 935/1727          | 888/1632 | 960/1665 | 1005/1685 | 834/1621                 | 940/1692                 |
| AXLE LOAD UNLADEN, FRONT/REAR              | 540/210     | 592/230  | 632/246  | 639/249  | 789/383  | 810/394            | 823/400           | 827/402  | 849/413           | 633/287  | 706/319  | 750/340   | 652/403                  | 768/464                  |
| HEIGHT, MAST LOWERED                       | h1 mm 1965  | 1785     | 2250     | 2425     | 1985     | 1994               | 2089              | 2285     | 2294              | 1965     | 1765     | 2265      | 1765                     | 2099                     |
| FREE LIFT                                  | h2 mm 1510  | -        | 80       | 80       | -        | 1370               | 1470              | -        | 1675              | 1510     | -        | -         | -                        | -                        |
| LIFT                                       | h3 mm 1510  | 2410     | 3410     | 3760     | 4110     | 4110               | 4410              | 5025     | 5025              | 1510     | 2410     | 3410      | 2410                     | 4410                     |
| HEIGHT, MAST EXTENDED                      | h4 mm 1965  | 2990     | 3915     | 4265     | 4725     | 4734               | 5029              | 5635     | 5644              | 1965     | 2970     | 3970      | 2970                     | 5039                     |
| INITIAL LIFT                               | h5 mm -     | -        | -        | -        | -        | -                  | -                 | -        | -                 | -        | -        | -         | 120                      | 120                      |
| <b>BATTERY</b>                             |             |          |          |          |          |                    |                   |          |                   |          |          |           |                          |                          |
| BATTERY VOLTAGE, NOMINAL CAPACITY C5       | V/Ah 24/225 | 24/300   |          |          |          |                    |                   |          |                   |          |          |           |                          |                          |
| BATTERY WEIGHT                             | kg 270      | 270      |          |          |          |                    |                   |          |                   |          |          |           |                          |                          |

**Carter Internal Features**

The New LX design with its strong wheel protection guard integrated into the frame structure aimed to increase both stability and safety. Now the new strong ABS battery cover comes with hinges which speed up all ordinary battery maintenance operations.



**Total Width Reduction**

The LX maneuverability has been improved by reduction of total width from 850 mm to 800 mm and by side wheel always within the truck width even when pivoting, allowing the operator to handle goods in narrow spaces and corridors.

**Improved Tiller**

Improved tiller with lifting/lowering proportional control. Fully integrated system with throttle, safety pushbutton, horn, hourmeter, battery status indicator.



**Mast**

The wider mast combined with the new ergonomic tiller to make LX more agile and easy to use. A sticker ruler allows the operator to easily check the forks elevation by sight.









# Reel Clamps

Transport, rotate and lift reels - find the equipment perfect for your handling situation and avoid strain on arms and back!

### A World of Options:

- Handling of reels in vertical and horizontal position and reel that are clear of the floor
- Manual or electric rotation, with or without gearbox
- Reels with different reel diameters, lengths and weights
- With gripping arms or expanding mandrel



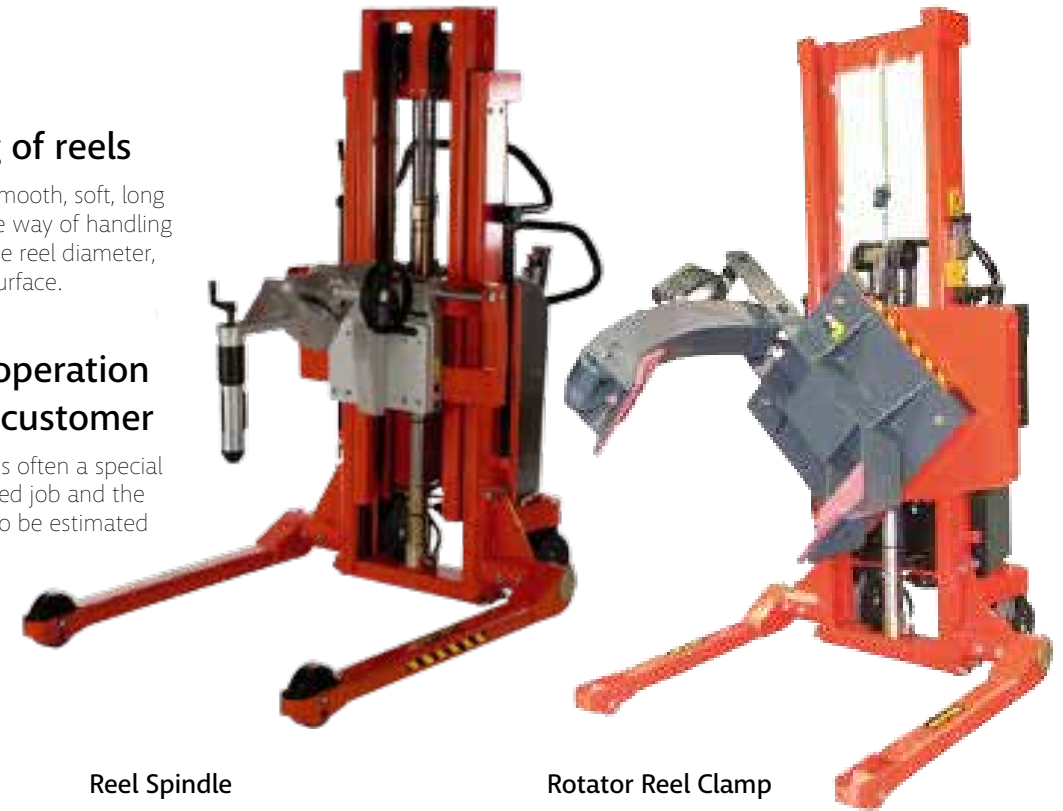
Reel Handler

### Handling of reels

Reels can be smooth, soft, long and heavy. The way of handling depends on the reel diameter, winding and surface.

### Close cooperation with the customer

Reel handling is often a special and complicated job and the options have to be estimated in each case.



Reel Spindle

Rotator Reel Clamp







Correct lifting methods when transporting, lifting, filling and emptying boxes, containers and crates...

**A World of Options:**

- Standing and sitting working position
- Easy access to the contents at the bottom
- Ergonomically correct working positions
- Minimum strain of back, shoulders and joints



Rotator with box holders



A drum is not just a drum... It is a fact that the market consists of a number of drums with different forms and measurements!

**A World of Options:**

- Handling of drums in horizontal and vertical position
- Emptying, rotating and transporting drums
- Handling of standard steel and plastic drums
- Special solutions for drums with different materials and dimensions

Logitrans helps you find the best way to handle your drum!



Drum Turner







### Correct lifting methods when transporting, lifting, filling and emptying boxes, containers and crates...

#### The drum forks

Lift and transport horizontal drums. The drum forks are available for both stackers and pallet trucks

#### The drum turner

Handles drums in the horizontal or vertical position and can rotate these 360°. Available in a manual or electric rotation model.



Drum Forks

Drum turner for steel drums

### Specific requirements:

#### Aggressive environments

The material has to be resistant to corrosion, acids, salts and scratches.

#### Strict hygiene requirements

The construction has to fulfil the strict requirements of hygiene and cleaning.

#### Environments, sensitive to static electricity

Surface tension has to be avoided and conductivity has to be optimised.

#### Clean rooms

The material handling equipment has to fulfil the requirements concerning dust particles in the air.



#### Explosive atmospheres

The material handling equipment has to conduct away static electricity, fulfil the stipulations of the ATEX-directive and may not be a source of ignition.





---

Lift Tables

267



## Single scissors and high-lift



### JIHAB Single

JIHAB Single is a single scissor lift table. This design is the basic model which forms the foundation of the entire JIHAB lifting table range. JIHAB Single can be used in a very wide range of applications in production, material handling and distribution, and as a component of a logistics system. JIHAB Single is a cost-effective handling product which can help you to design an ergonomically correct workplace.

JIHAB Single can be designed and equipped to meet user specifications and requirements.



### JIHAB High-lift

JIHAB High-lift has multiple vertical scissor packages. Using several vertical scissor packages gives higher lifting movement without increasing the length of the lifting table. This reduces space requirements. JIHAB High-lift can be used in places where large lifting movement is required. Such as in various types of lifts, working platforms and pallet stackers.

JIHAB High-lift can be designed and equipped to meet user specifications and requirements.



## Low profile and U-shaped low profile

### JIHAB Low profile/JIHAB Low profile U

Both models are designed as low-profile lifting tables, and do not require a pit in the floor - this makes them much more flexible and gives them a wider range of potential applications. JIHAB Low profile is provided with a ramp when goods are handled with a pallet lifter.

JIHAB Low profile U does not need a ramp, it can be loaded and unloaded directly from the floor with a pallet lifter. Both types of lifting table are suitable for use in a correctly designed ergonomic workplace. JIHAB Low profile and JIHAB Low profile U have the same performance:

#### Performance:

- Lifting capacity up to 2,000 Kg
- Lifting movement 800 mm
- Lifting table size max 1,400 x 1,200 mm

Both models can be designed and equipped to meet user specifications and requirements. JIHAB Single can be designed and equipped to meet user specifications and requirements.



## Vehicle carrier and Low cost models

### JIHAB Vehicle

JIHAB Vehicle is only intended for transporting cars/vehicles between different floors, such as in sales and exhibition halls and multi-storey car parks. The lifting table is designed for even loading. It is not intended for passenger carrying. Special user instructions and safety rules apply to installation and operation. JIHAB Vehicle can be designed and equipped to meet user specifications and requirements.



### JIHAB Low-cost

JIHAB Low-cost is available as standard units which can not be specially equipped or designed to suit customer requirements.

They are offered at a very attractive price for traditional lifting table use. JIHAB Low cost is not designed for continual use in production lines etc.



#### Performance:

- Lifting capacity 500, 1,000 and 2,000 Kg
- Lifting movement 800 mm
- Lifting table size max 1,200 x 800 mm or 1,350 x 800 mm

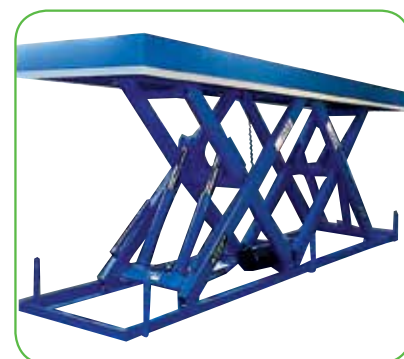
## Long load and loading dock

### JIHAB Long-load



JIHAB Long-load has multiple horizontally arranged scissor packages. Using several horizontally arranged scissor packages gives a longer table length and lifting capacity. The movement of the scissor packages is coordinated to give parallel lifting movement. JIHAB Long-load is an excellent choice when you need to handle long and heavy goods.

JIHAB Long-load can be designed and equipped to meet user specifications and requirements.



### JIHAB Loading dock



JIHAB Loading dock is designed for harsh environments and heavy loads. It is at its best when used for loading and unloading in a loading bay, often outdoors. This job subjects the lifting table to heavy loads, often concentrated to one point.

JIHAB Loading dock can be designed and equipped to meet user specifications and requirements.







---

Construction  
Equipment

273



**PROLIFT** Misc Equipment  
HANDLING LTD

Construction Equipment



Manhole Clamp



Pipe Suspension Grab



Pipe Layer



Round Grab



Manhole And Cone Grab



Pipe Laying Hook



Road Gully Grab



Manhole Housing Grab



Pipe Pulling Device



Pipe Puller



Hydro Grab



Aluminium Tripod with winch

Lifting Equipment



Kerb Stone Lifter



Stele Clamp



Border Stone Lifter



Flat Grab

Rollers



Lifting Beam



Load Rotating Beam



Ride-on Roller



Hand Roller

Gantry Cranes



Gantry Crane



Frame Crane



Mobile Aluminium Crane



Mobile Job Crane

Vacuum Technology



Alpha Levator



Turbo M Levator



Turbo H Levator



Gamma Levator + SP 500

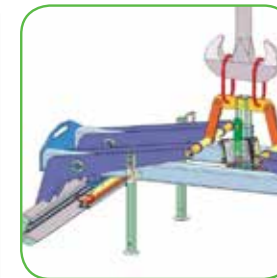


Uni Levator



Kappa Levator

Customised Solutions



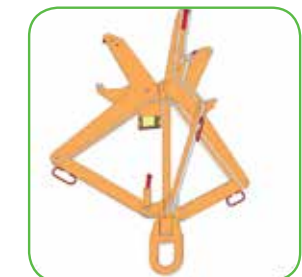
Grab for Railway Sleepers



Round Grab



Load Rotating Beam



Coil Grab



Adjustable Lifting Beam



Vacuum Lifter



---

Plant Machinery  
Safety Devices

277





## Product Application Guide

### Company Profile

Prolift are proud to be distributors of GKD products. GKD specialise in the design, development and production of electronic safety systems for the Rail, Construction, Extraction, Waste and Distribution industries.

GKD Technik's core products are sophisticated rated capacity indicators and positional control systems for the Road Rail industries, in which GKD Technik Ltd is a recognized worldwide market leader.

GKD Technik also produces Rated Capacity Indicators, Height Control systems and Incline monitoring for off highway vehicles in the Construction and related industries, and has recently developed an innovative long range RFID based

Proximity Warning system designed to enhance pedestrian safety and reduce the incidence of collisions between vehicles and pedestrians in the workplace.

GKD Technik designs and develops all of its products in house, all system software is written and tested in house, and all product manufacturing is carried out either in house or using local specialist contractors.

### Rail Products

#### 3RCI Road Rail Rated Capacity Indicator

GKD's 3RCI system is the world's most popular retrofit Rated Capacity Indicator for Road Rail applications.

3RCI monitors the machine's load status and compares it to the machine's true lift capacity in its state of gradient, rail cant and axle lock configuration. Slew, Cant and Gradient duties are continuously calculated to make full use of the machine's lift capacity in every position.

Tandem Lift function is included as standard.

Full Intelligent motion cut of all booms plus slew on overload, allows recovery to a safer state but prevents movement further into overload. Angular Slew Limits, Virtual Walls and Height Limits are all included, selective Intelligent hydraulic motion cut of any boom or slew function at limit to prevent movement further into danger but allow recovery into the "safe" zone.

Full data logging of all functions and operational state is included.

An optional telemetry unit includes GPS, GRPS and WiFi modules and allows local communication between machines and controllers, and remote data transmission and fault diagnosis.



#### 3RCI Spaceguard

Spaceguard is a variant of the 3RCI with dual sensing of all booms plus slew and cant / gradient and dual processing of all positional functions. Spaceguard is supplied with direct drive boom angle sensors and digital encoder based slew sensing, and is intended for use under live overhead

cables and alongside lines open to live traffic. Fully Dual Redundant, any positional mismatch between sensors causes an error state to be detected and all booms plus slew are hydraulically motion cut. Slow valves are activated when approaching any positional limit to eliminate limit breach, even when operating at speed.

### Systems for Civil Engineering, Waste and Recycling, Distribution

#### Height Limiting

##### 1HLI

A basic, inexpensive height limiter intended for use on excavators, wheel loaders, telehandlers etc.

1HLI consists of an angle sensor mounted on the variable position boom, and a display at the operator station. A Gravity Referenced angle sensor or a Direct Drive angle sensor can be specified to suit the application. The Height limit is variable and is set from the operator station using a Keyswitch to set limits, the key may be removed once the limit is set to prevent tampering.

On achieving the height limit an audible alarm sounds and an optional motion cut valve stops boom upward movement preventing movement further into the Danger zone but allowing movement away from the height limit in the safe direction.



##### 1HLI-R

A variant of the 1HLI developed for the Australian Rail industry, this Dual Redundant system uses both direct drive and gravity referenced angle sensors on the primary boom to sense the boom position.

A mismatch between the two angle sensors causes an Error state to be triggered. Vehicle gradient is automatically compensated for. Additional outputs will drive external status lamps to indicate height limiter status.



##### 2HLE

A more sophisticated height limiting system, with a colour touchscreen display at the operator station.

2HLE places angle sensors on each articulating boom, and provides height limiting for the entire articulated boom structure. Multiple motion cuts are intelligently applied to prevent height limit infringements by any part of the articulating boom structure.

2HLE is generally specified for excavators and multi - arm cranes or mowers.



#### Load Monitoring Systems

##### 1TMI

A fairly simple and inexpensive load monitoring system, intended for installation on excavators, lorry mounted cranes, wheel loaders and telehandlers.

1TMI consists of an angle sensor to be mounted on the primary boom, and a pressure transducer to be installed in the lift cylinder hydraulic circuit. Hydraulic pressure is matched to the primary boom angle, and the display at the operator station indicates the load status of the machine using a series of coloured LEDs, set to light up at 50%, 75% and 100% of maximum load. An audible alarm sounds at 100% of load, and an internal relay allows control of an external alarm or lamp or motion cut valve where required. Secondary boom position or telescopic boom state are automatically taken into account. A mimic display is available where two displays are required.







## 2RCI

A more sophisticated load monitoring system for excavators, designed to satisfy LOLER regulations regarding use of an excavator as a crane. Angle sensors are fitted to each boom, and the display calculates and shows the current lift point height and radius, plus the machine's Rated Capacity for that height and radius, and the Load on Hook. A bar scale shows the proportion of lift capacity currently being used. An Amber alert is triggered, with internal audible alarm, when the load is at 95%, and a Red alert with external audible alarm is triggered at 104% of the machine's rated capacity for the height and radius. Additional duties allow for different capacity in different configurations, for instance road axle locked / unlocked on wheeled excavators, or with stabiliser legs deployed.

A Dig mode turns the Overload alarms off and instead used the boom angle sensors to calculate and display the bucket elevation against a datum for use as a basic Grade tool.

A height limit function is also included, with optional hydraulic motion cut of booms to prevent over height working.

Additional Optional expansion modules are available to provide full, Intelligent hydraulic motion cut of all booms on Overload, automatic lifting duty selection based on slew position, and full Data Logging.



## Incline Alert

Incline Alert is a simple, inexpensive Incline monitoring system, designed to be installed on mini excavators, rollers, front tipping dumpers, ADTs and any other item of plant that works on slopes and inclines and is at risk of overturn.

A Pitch and Roll sensor monitors the incline of the machine against preset limits and warns the operator when the incline limit is reached. Separate incline limits can be set for facing up the slope, down the slope and across the slope. All incline limits are data logged, and should the machine overturn during use, an LED is turned on that cannot be turned off again except by an authorised engineer.



## Proximity Warning System (PWS)

PWS Proximity Warning has been developed to help protect pedestrians working on busy jobsites shared with vehicles and items of plant.

PWS is an RFID radio system consisting of two parts, one being a transmitter / receiver fitted to the item of plant, and the other being a small radio Tag, worn by pedestrians on site, usually in an arm band.

The system on the machine constantly scans the local area around the machine, with a customisable range of 2 - 8 meters. As soon as a pedestrian tag "sees" this radio scan from the machine, it wakes up and transmits an identifier on a different frequency. This identifier is picked up by the receiver on the machine, and the machine operator is immediately alerted to the presence of the pedestrian by means of an audible alarm and an LED warning.

The driver must acknowledge the presence of the pedestrian to silence the alarm, or the pedestrian must move back out of range of the machine's scanned range. The system can be fitted to multiple machines on a site, and will cope with multiple tags.

All alarm states are data logged with time, data and tag identity. An optional GPRS telemetry unit uploads the data log from each machine automatically to a server based web site, where the data can be analyzed.

PWS is also well suited to warehouse environments, fitted to forklift trucks, and may be of help in preventing forklift trucks from colliding, in addition to the pedestrian safety benefits of the system.

